



(12) **UK Patent** (19) **GB** (11) **2 384 807** (13) **B**

(45) Date of publication: **01.10.2003**

(54) Title of the invention: **A method of extracting materials from a wellbore**

(51) Int Cl<sup>7</sup>: **E21B 43/10 43/14**

(21) Application No: **0308302.9**

(22) Date of Filing: **23.02.2000**

Date Lodged: **10.04.2003**

(30) Priority Data:  
(31) **60121702** (32) **25.02.1999** (33) **US**

(62) Divided from Application No  
**0004282.0** under Section 15(4) of the Patents  
Act 1977

(43) Date A Publication: **06.08.2003**

(52) UK CL (Edition V):  
**E1F FLA FLW**

(56) Documents Cited:  
**GB 2343691 A**

(58) Field of Search:  
As for published application 2384807 A viz:  
UK CL (Edition V) **E1F**  
INT CL<sup>7</sup> **E21B**  
Other: **EPODOC, WPI, JAPIO**  
updated as appropriate

(72) Inventor(s):  
**Robert Lance Cook**  
**David Paul Brisco**  
**R Bruce Stewart**  
**Lev Ring**  
**Richard Carl Haut**  
**Robert D Mack**  
**Alan Duell**

(73) Proprietor(s):  
**Shell Internationale Research**  
**Maatschappij B.V.**  
**(Incorporated in the Netherlands)**  
**Department IP/43 Carel Van Bylandtlaan**  
**30, 2596 HR The Hague, Netherlands**

(74) Agent and/or Address for Service:  
**Haseltine Lake & Co**  
**Imperial House, 15-19 Kingsway,**  
**LONDON, WC2B 6UD, United Kingdom**

2389807

1/47

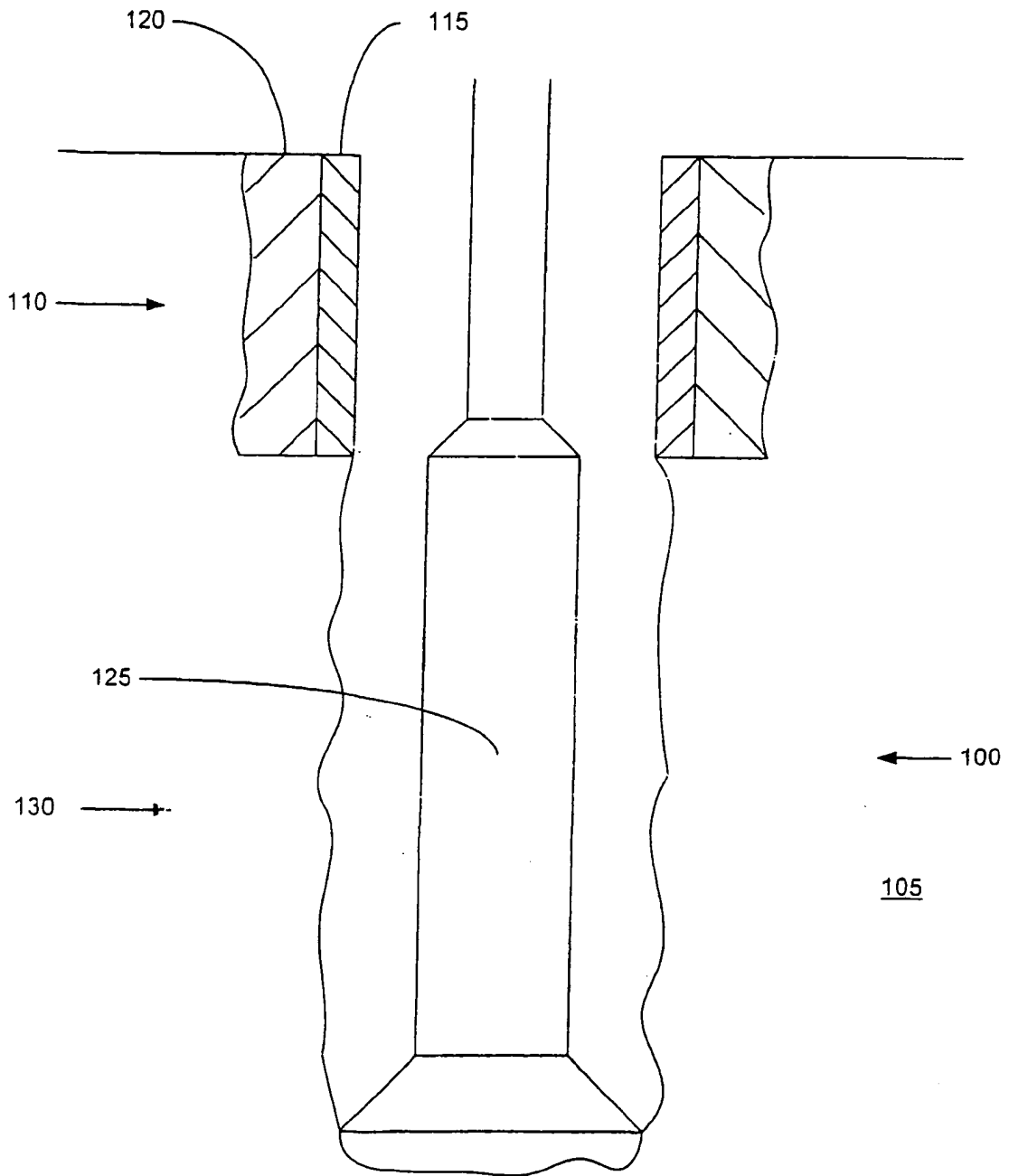

FIGURE 1

2/47

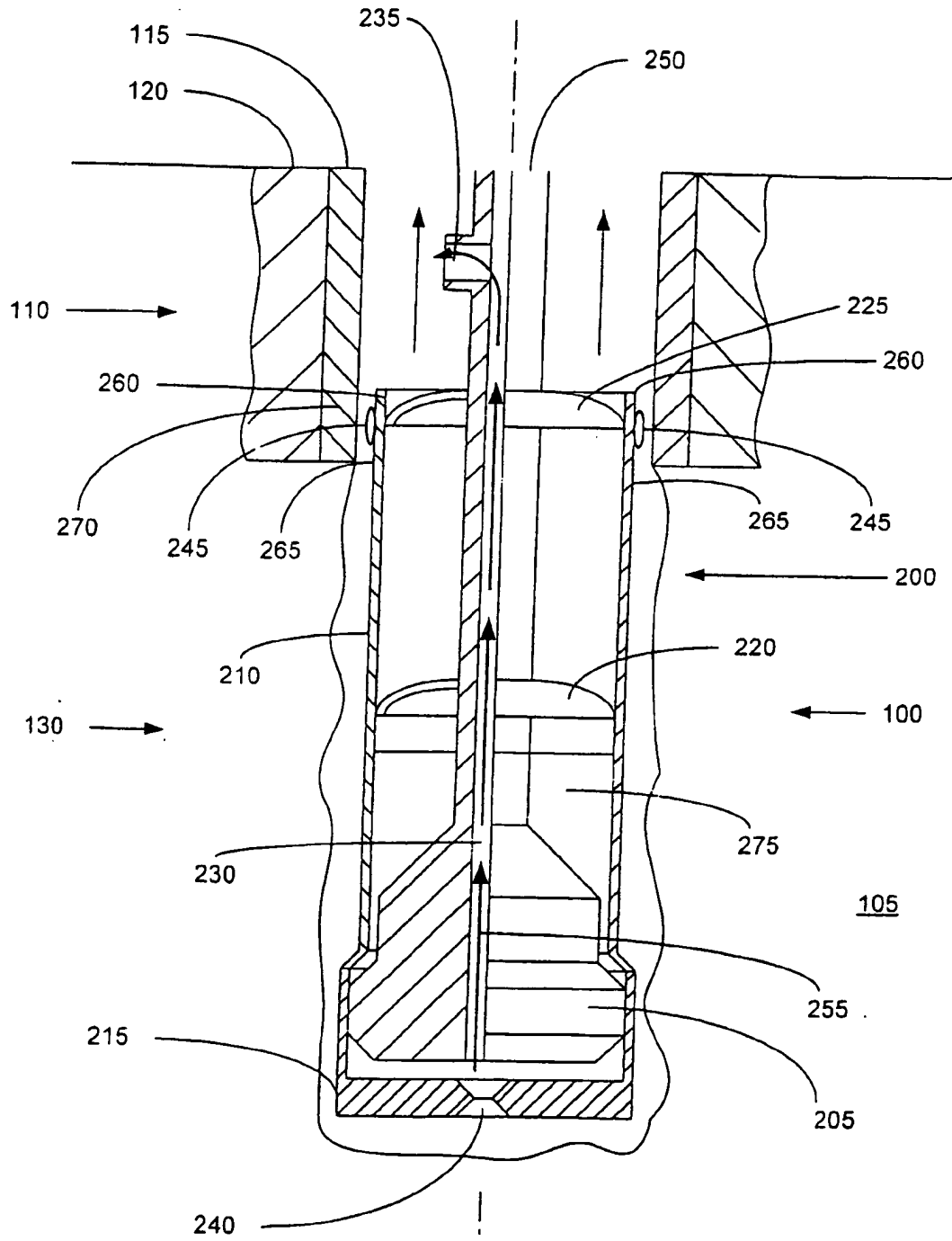

FIGURE 2

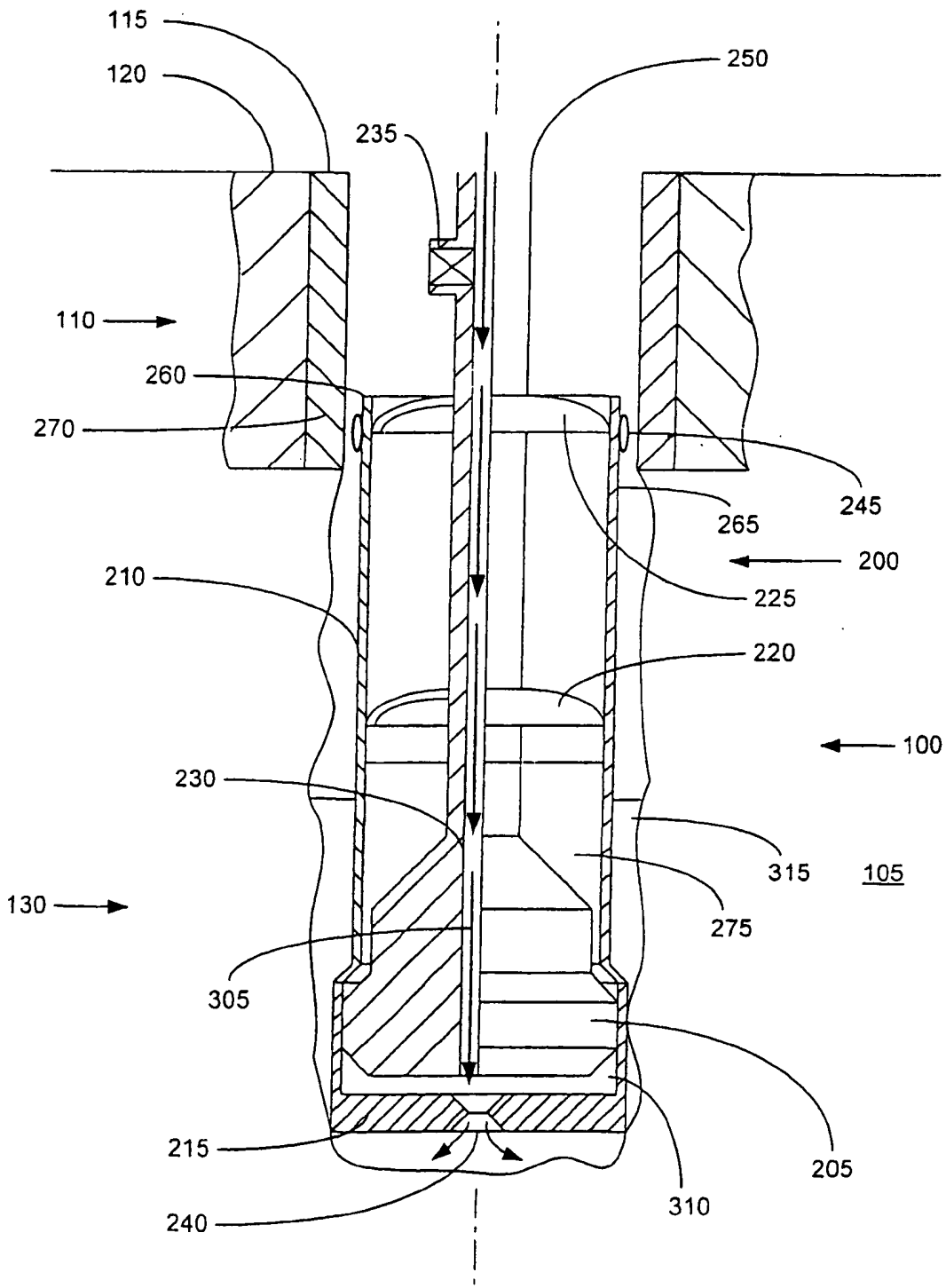

FIGURE 3



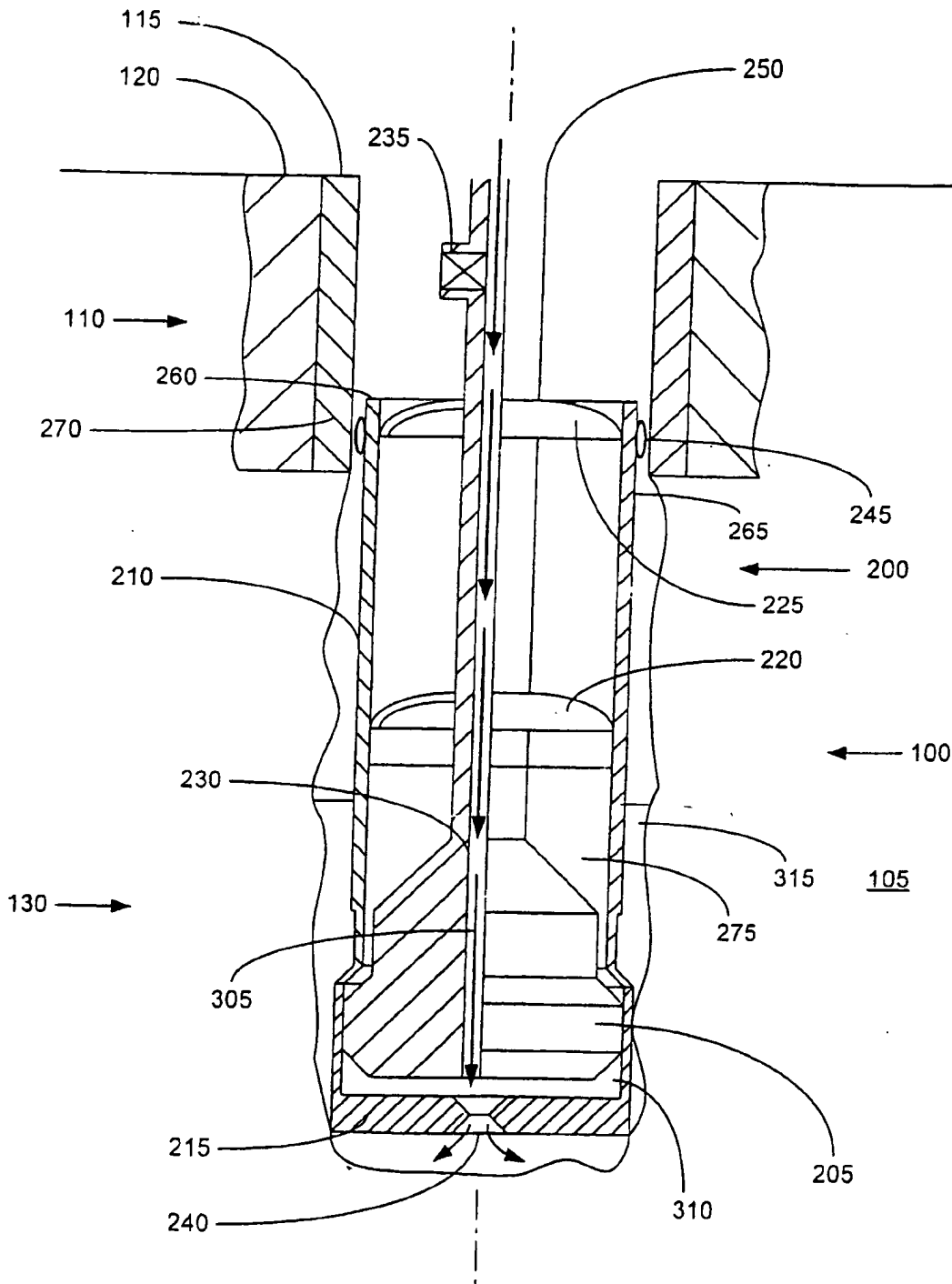

FIGURE 3a

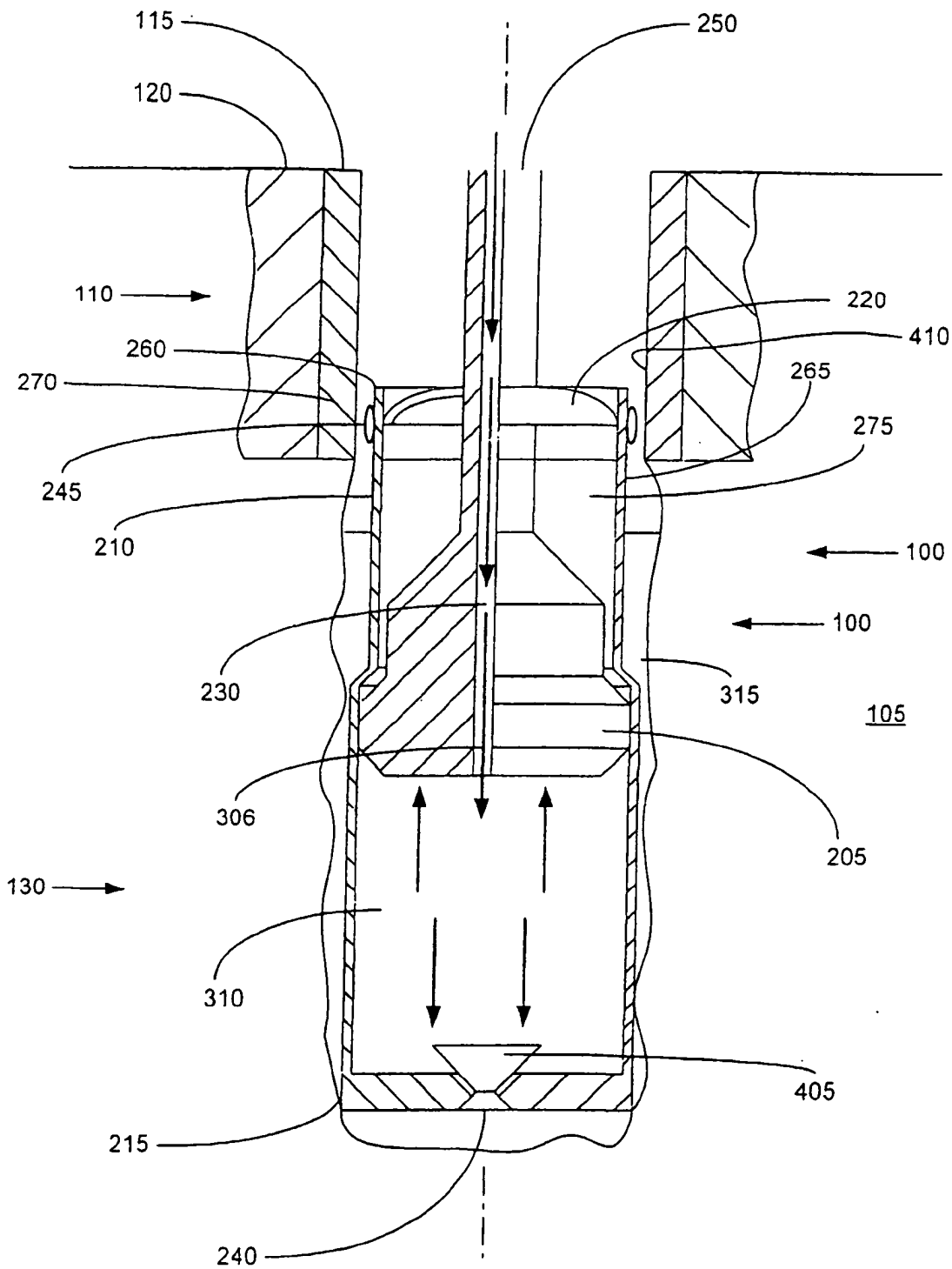

FIGURE 4

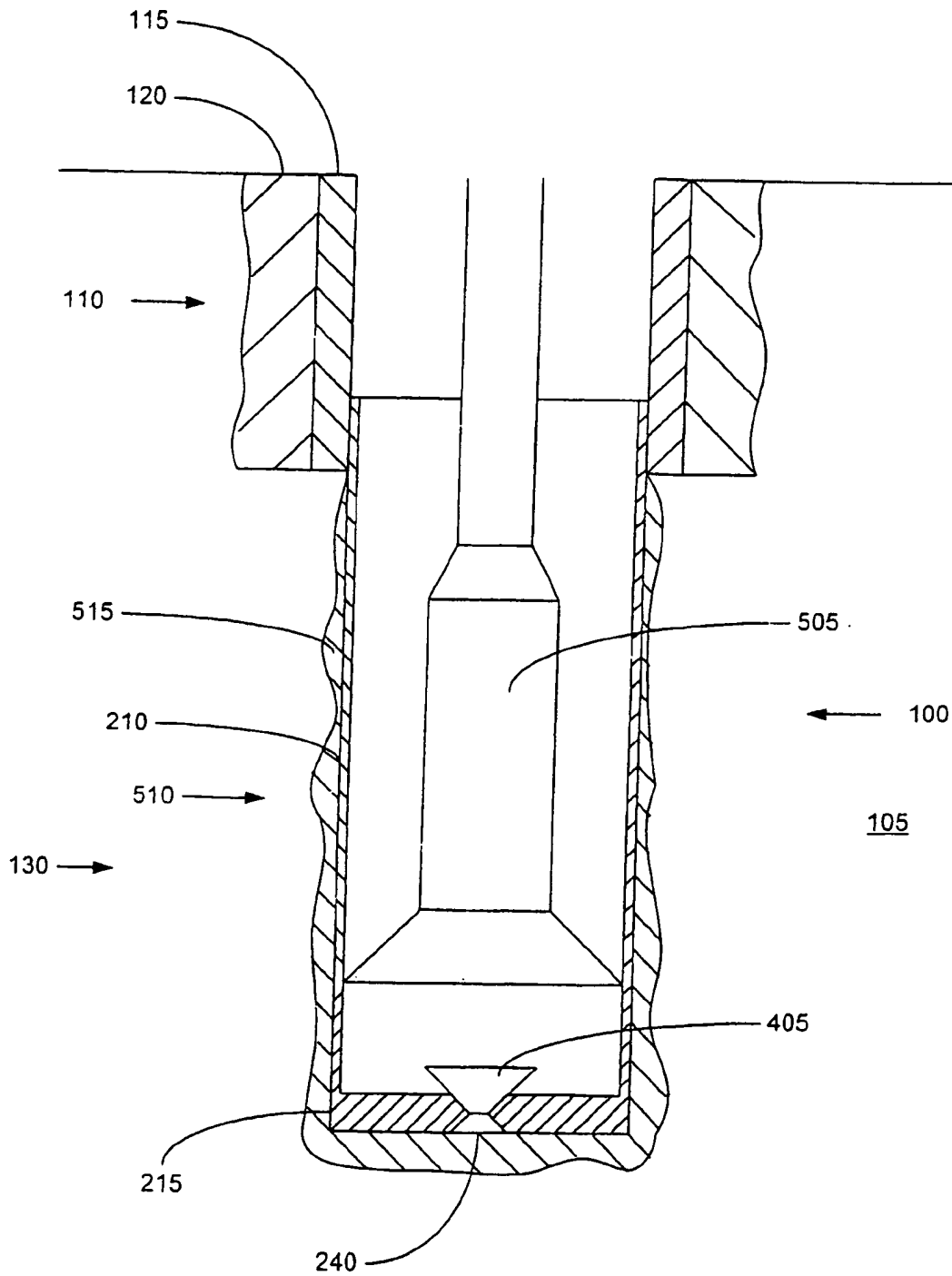

FIGURE 5

7/47

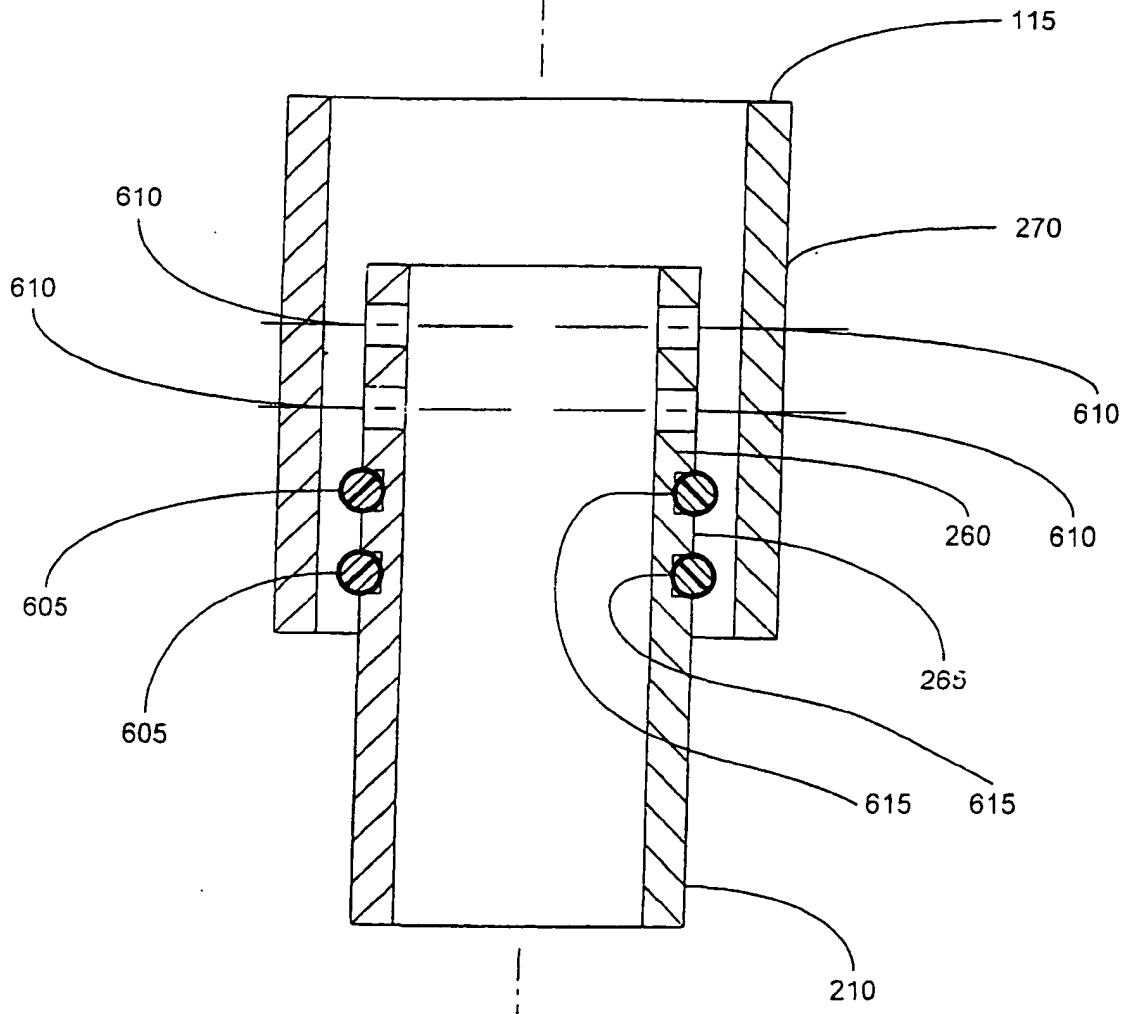

FIGURE 6-

8/47

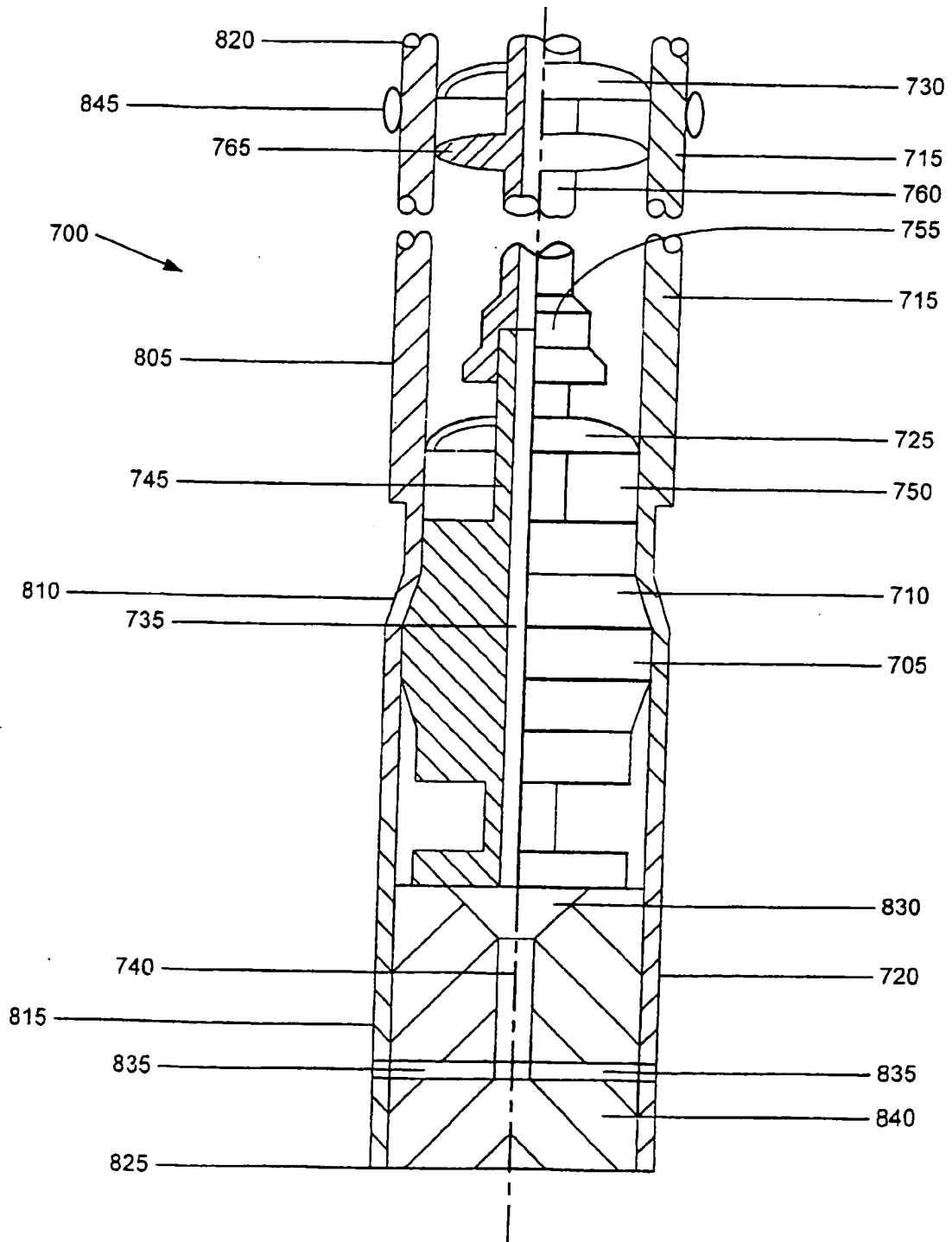
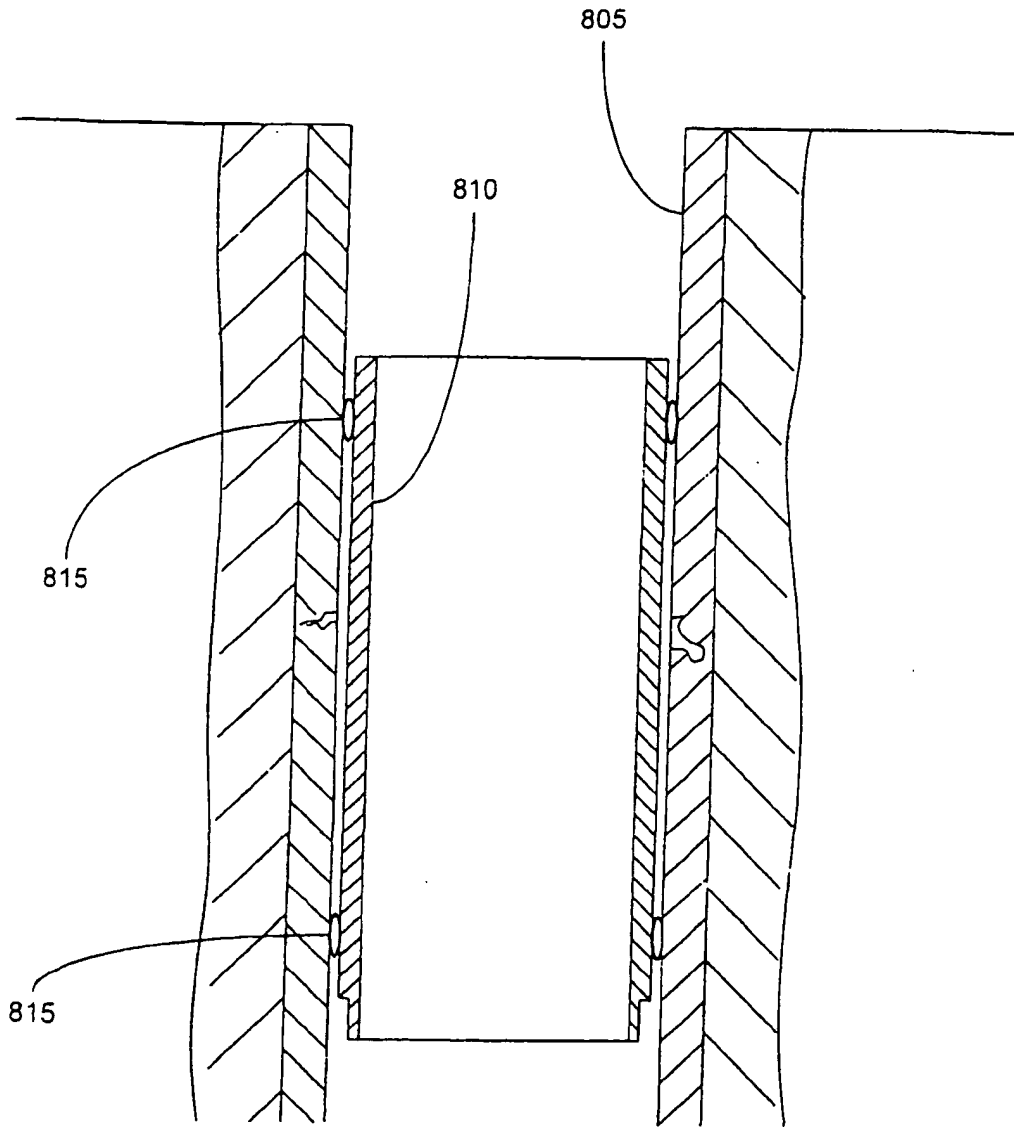

FIGURE 7

9/47



FIGURE\_8



11/47

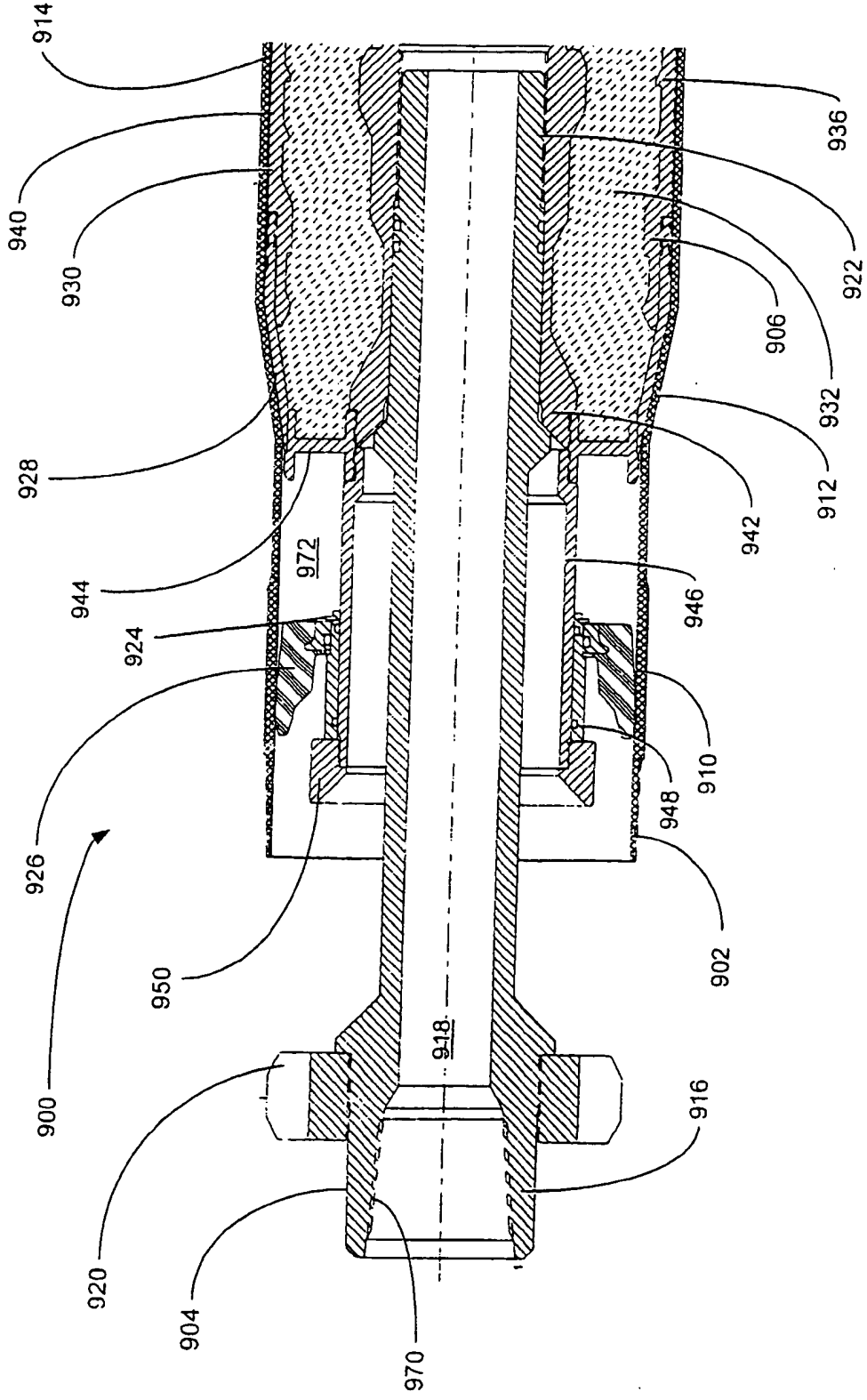

FIGURE 9a



12/17

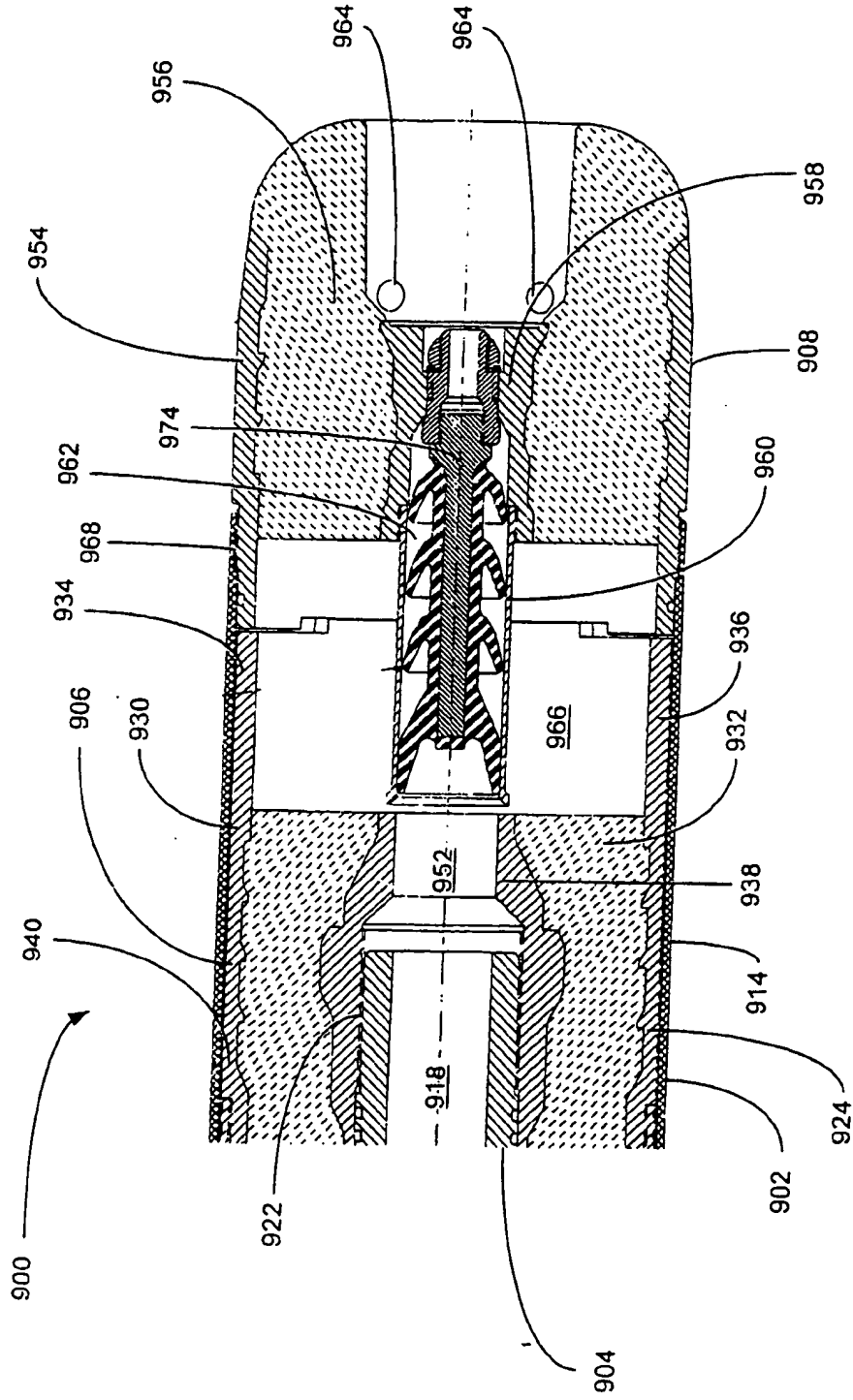

FIGURE 9b

13/47

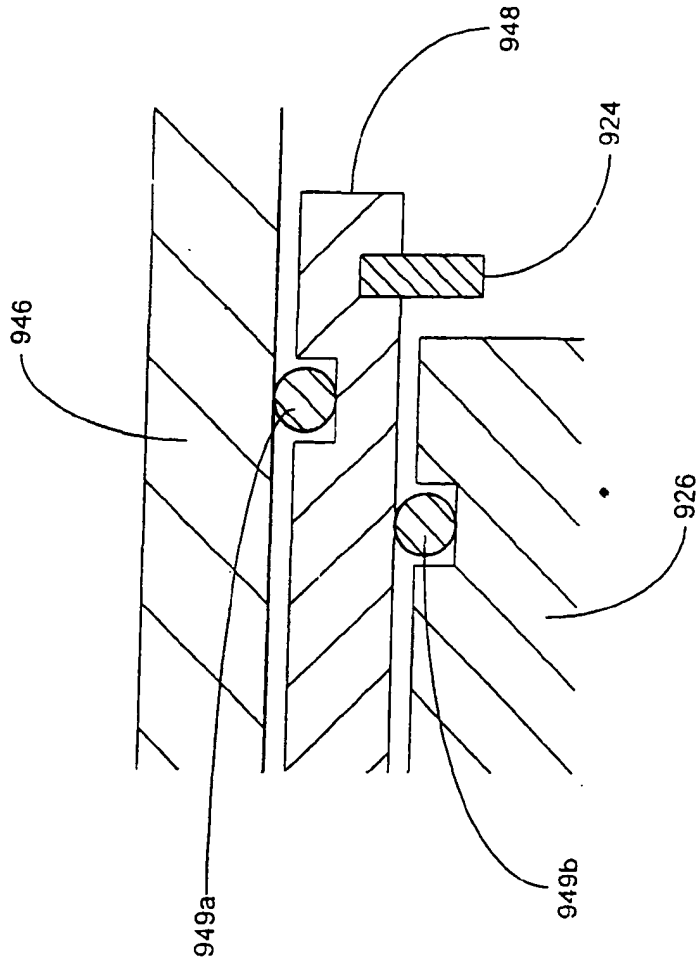

FIGURE 9C

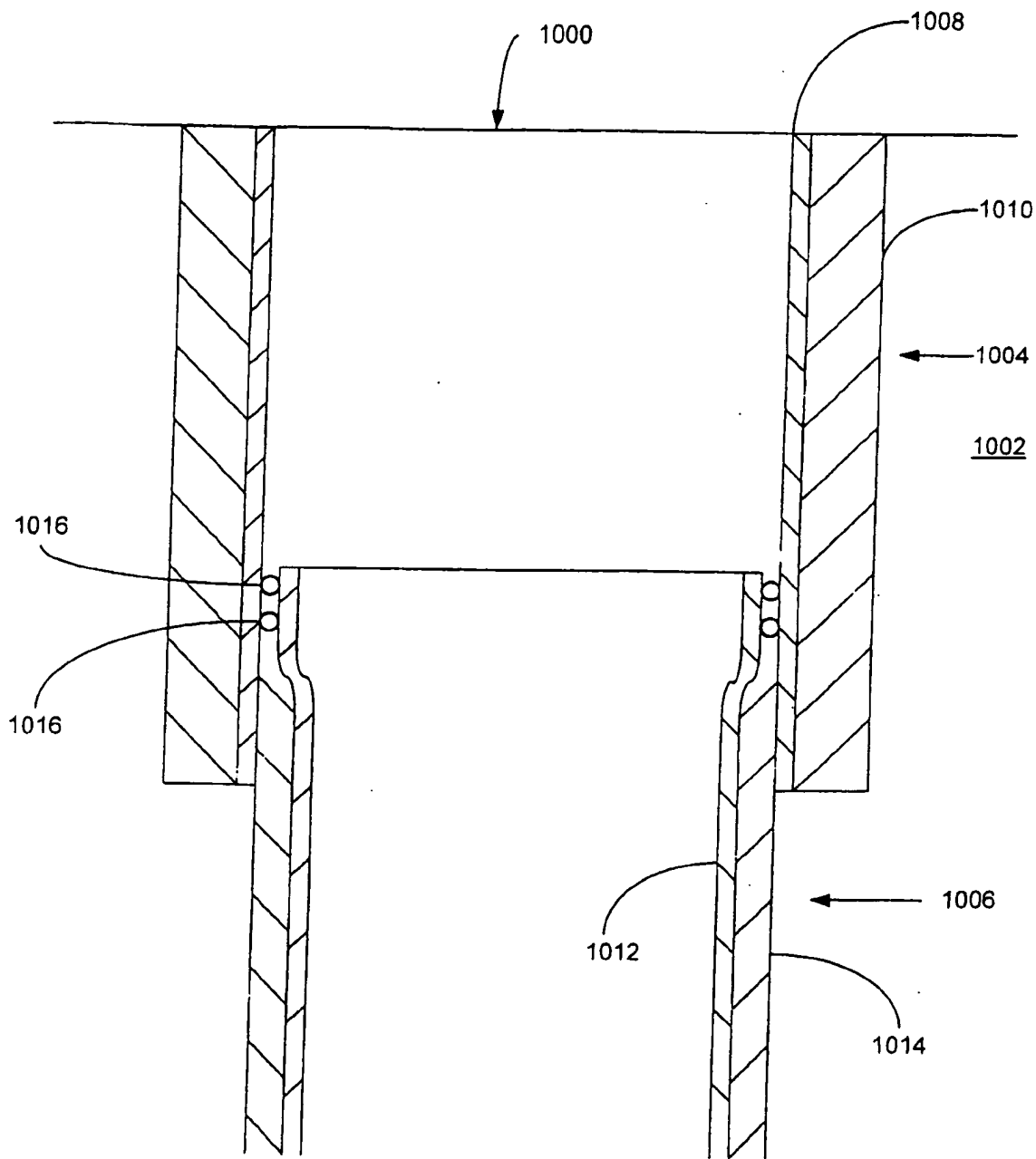

FIGURE-10a

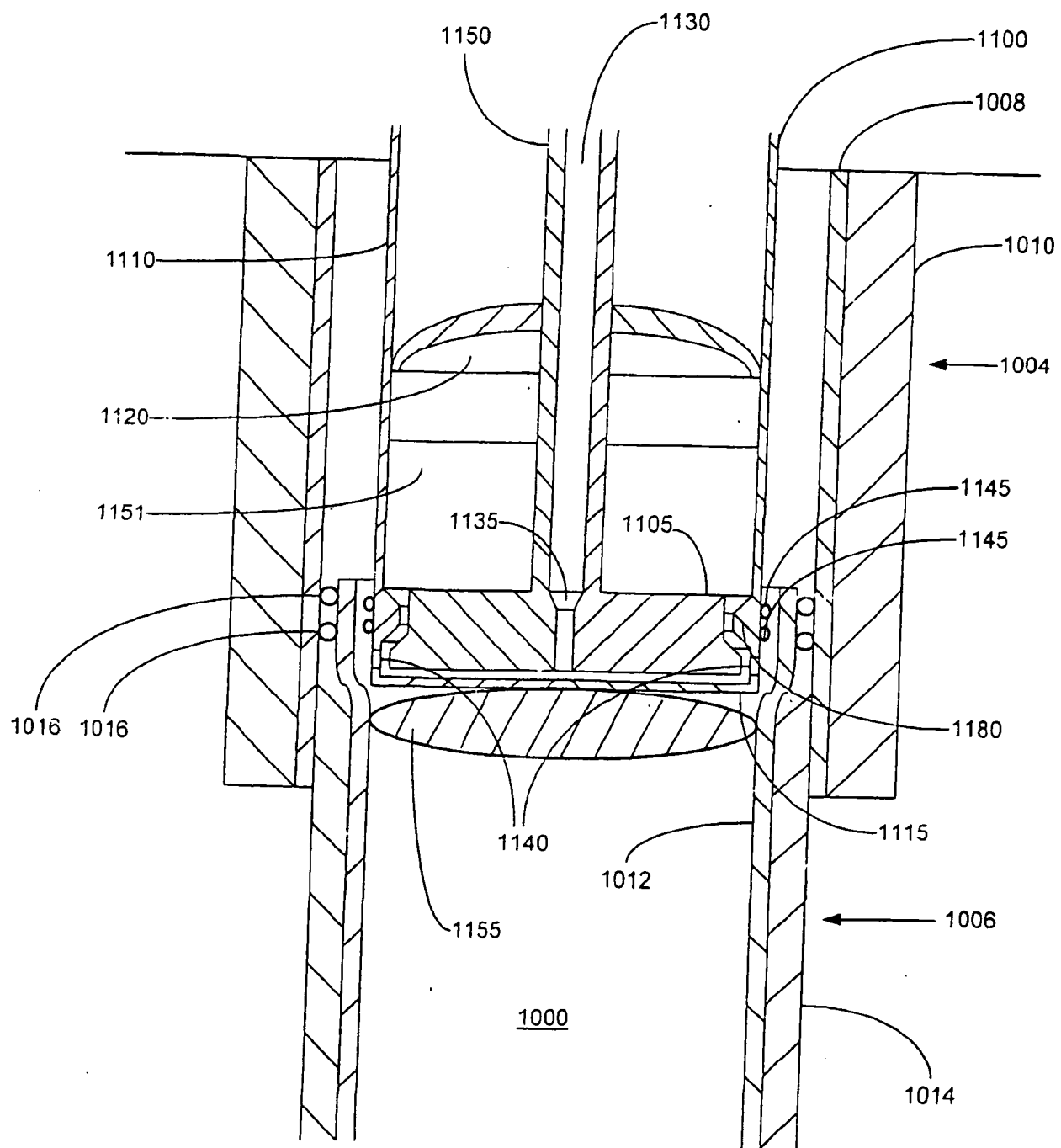

FIGURE 10b

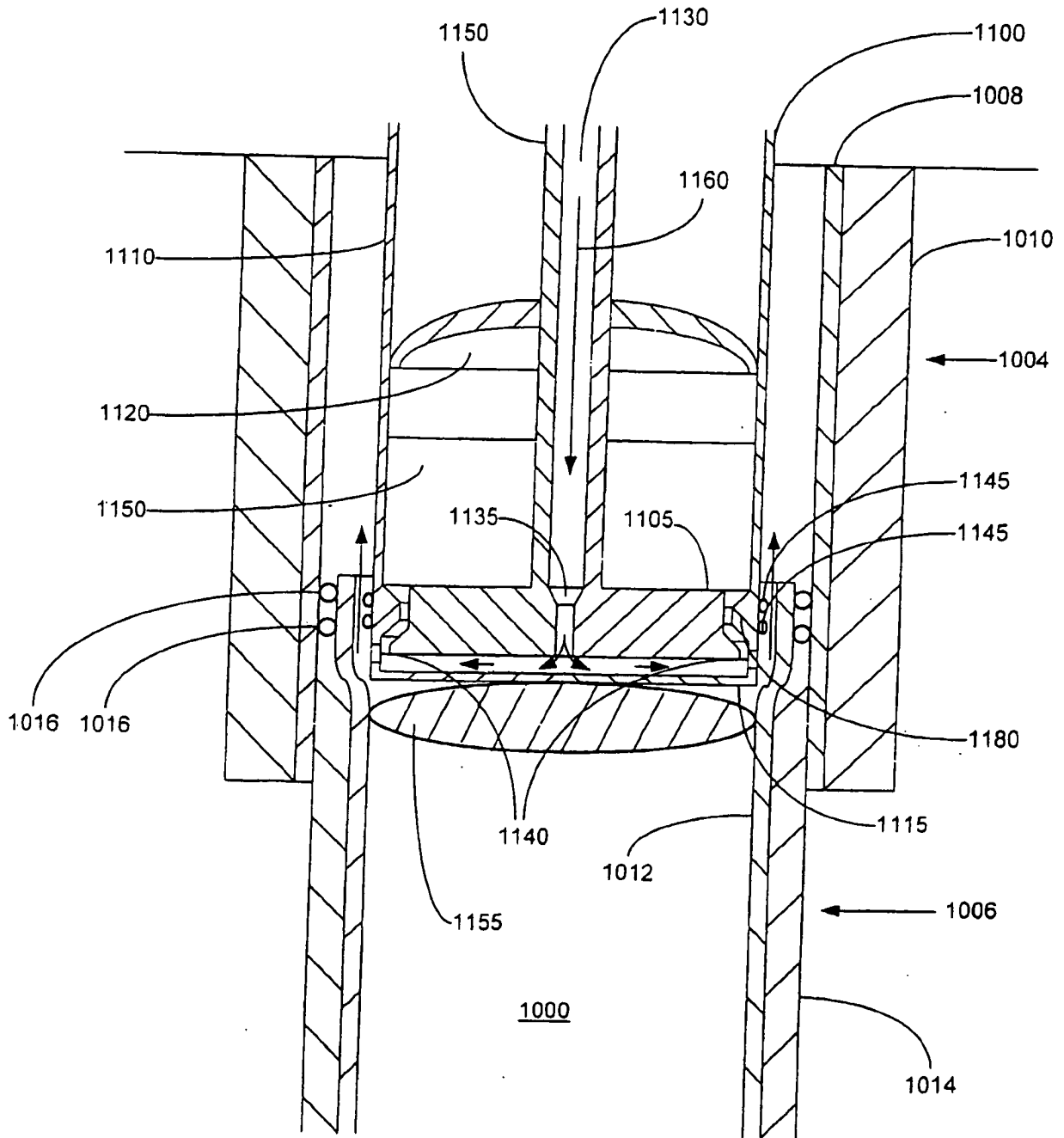

FIGURE 10c

17/47

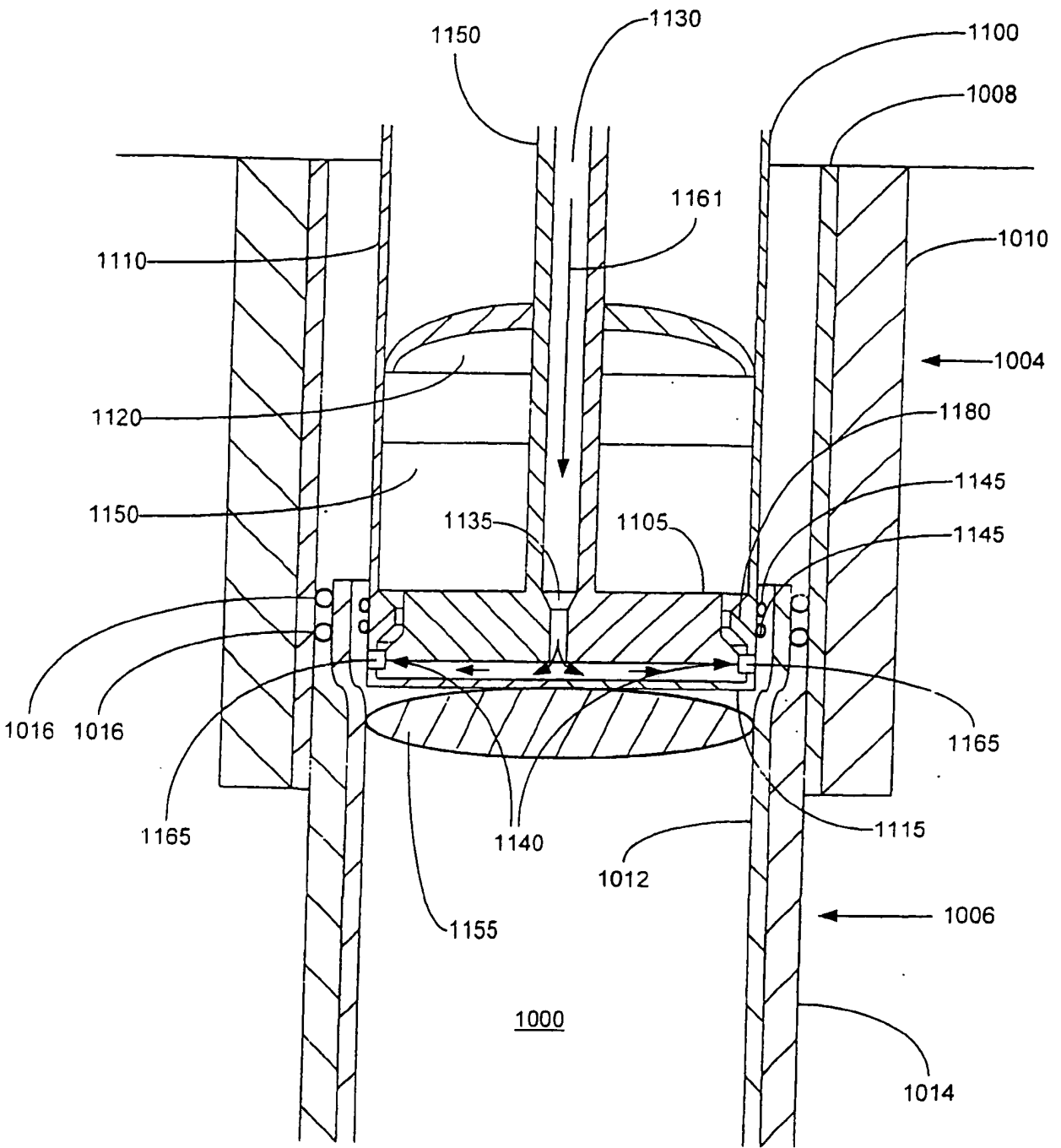

FIGURE 10d

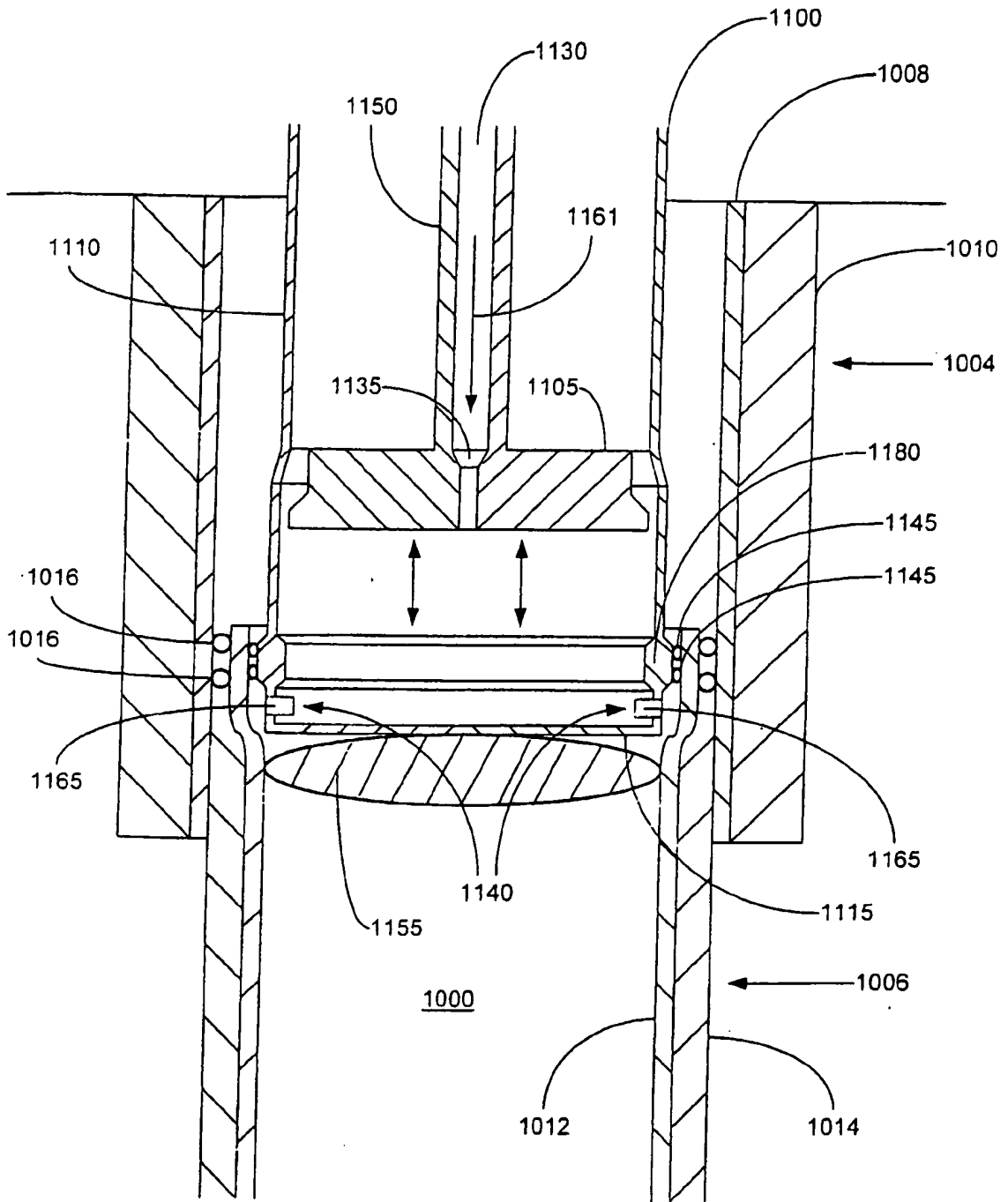

FIGURE 10e





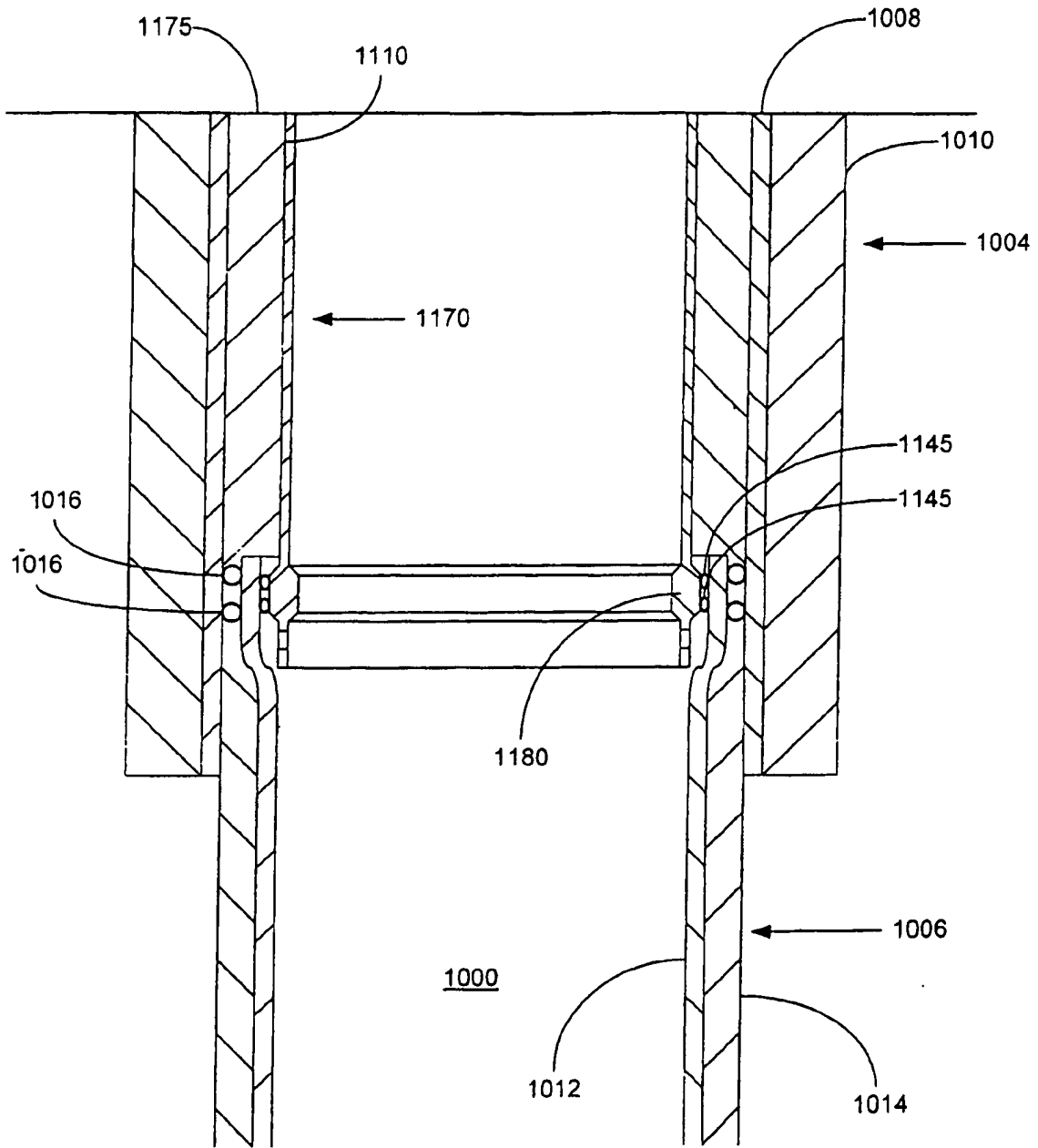

FIGURE 10g

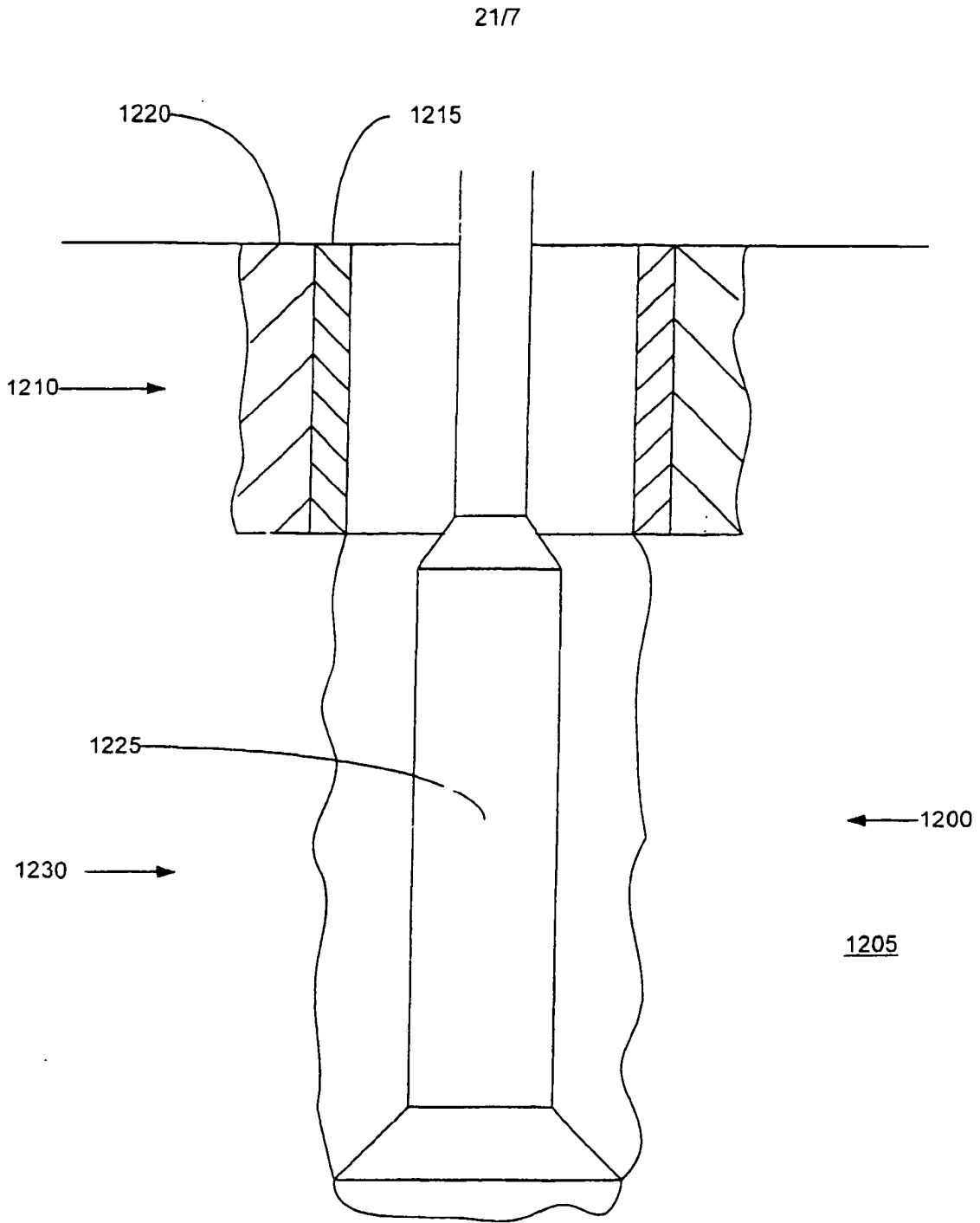

FIGURE 11a

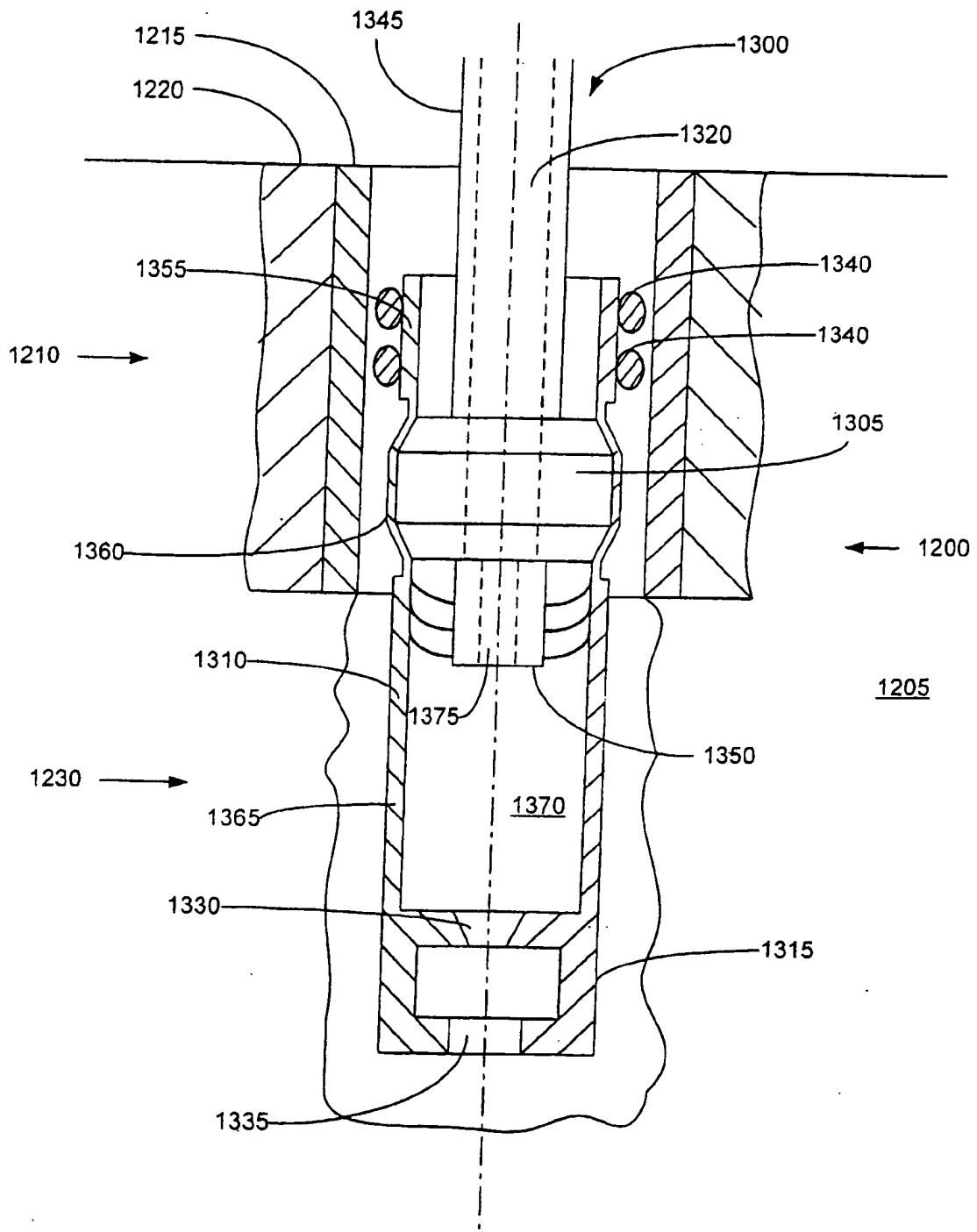

FIGURE 11b

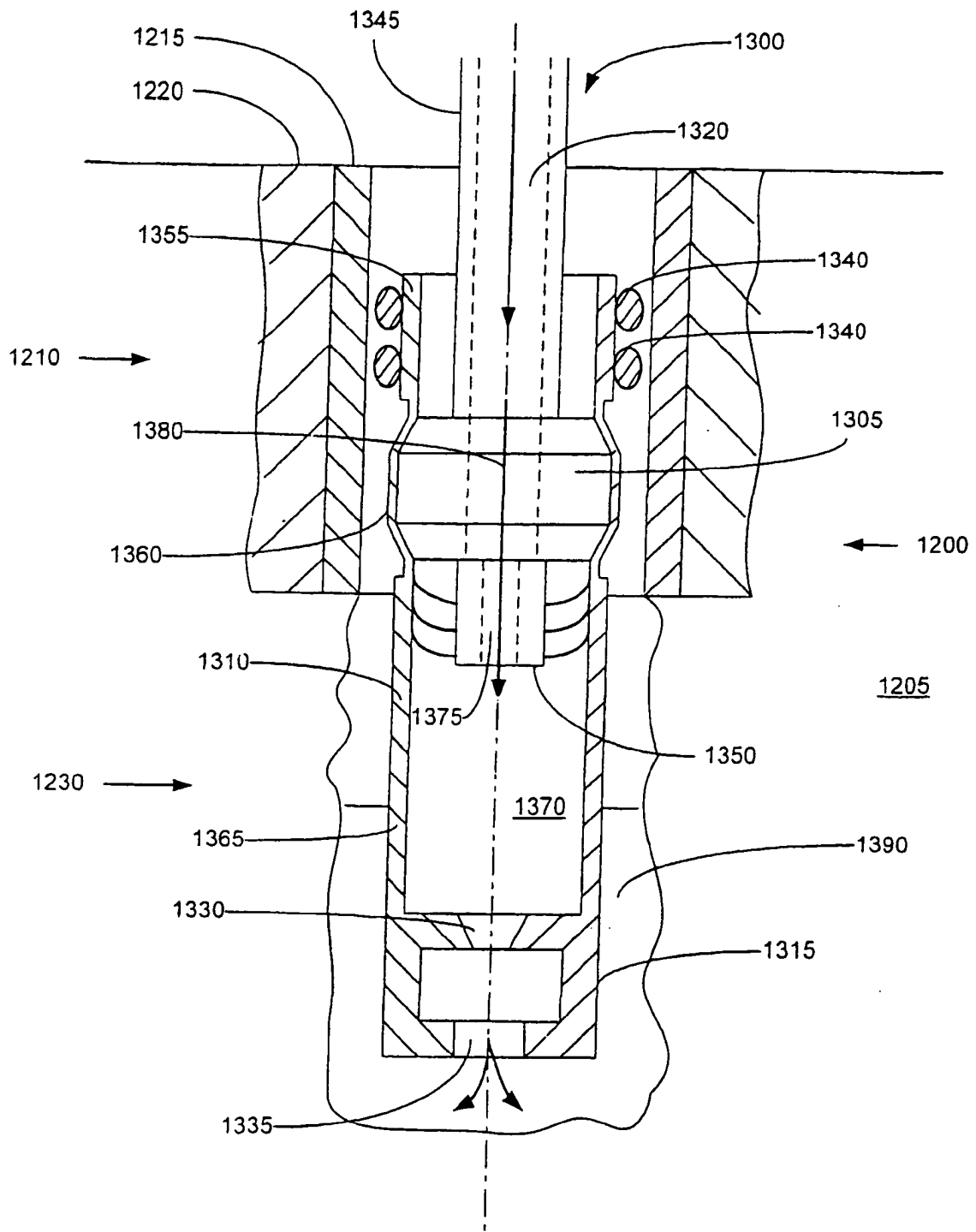

FIGURE 11c

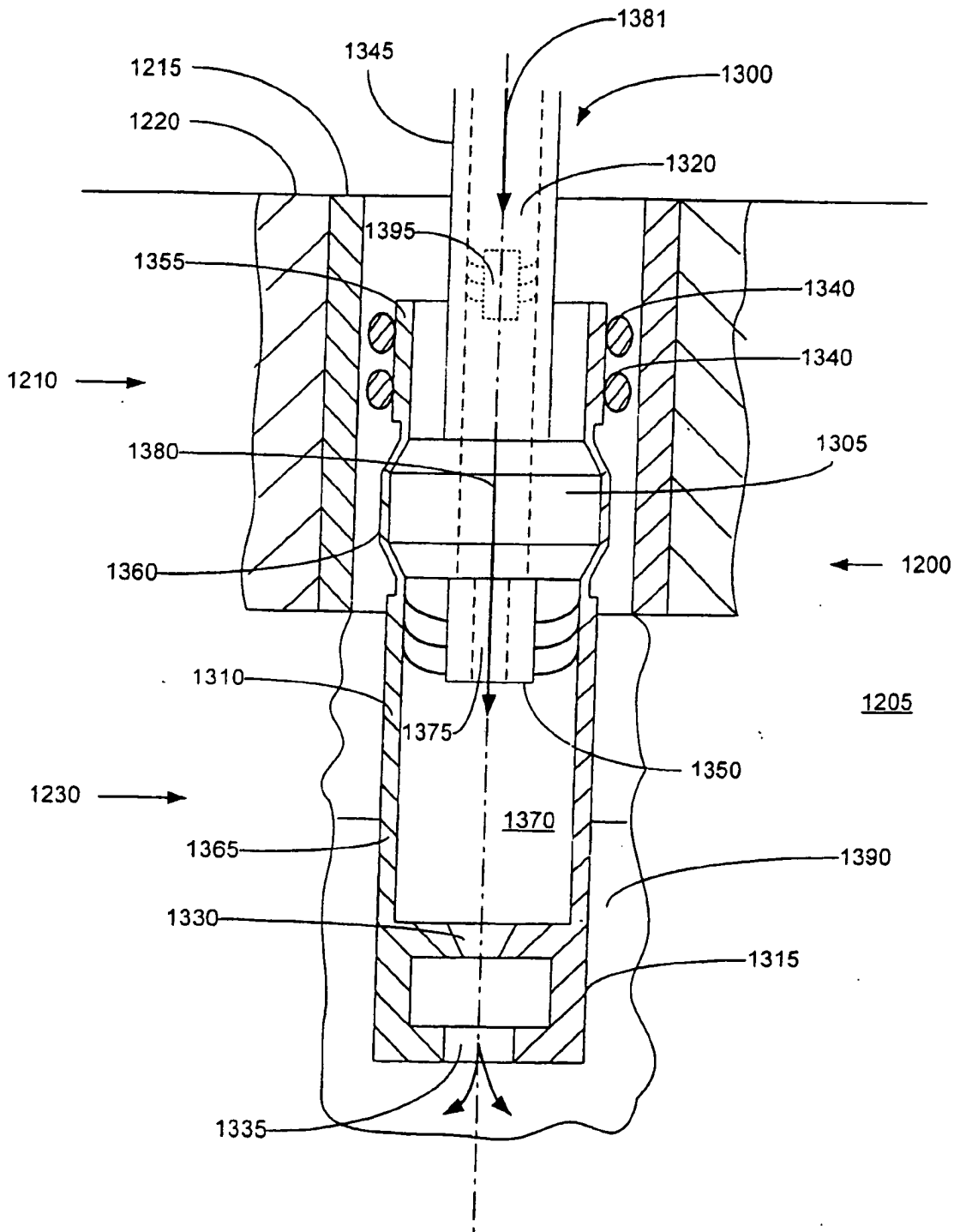

FIGURE 11d

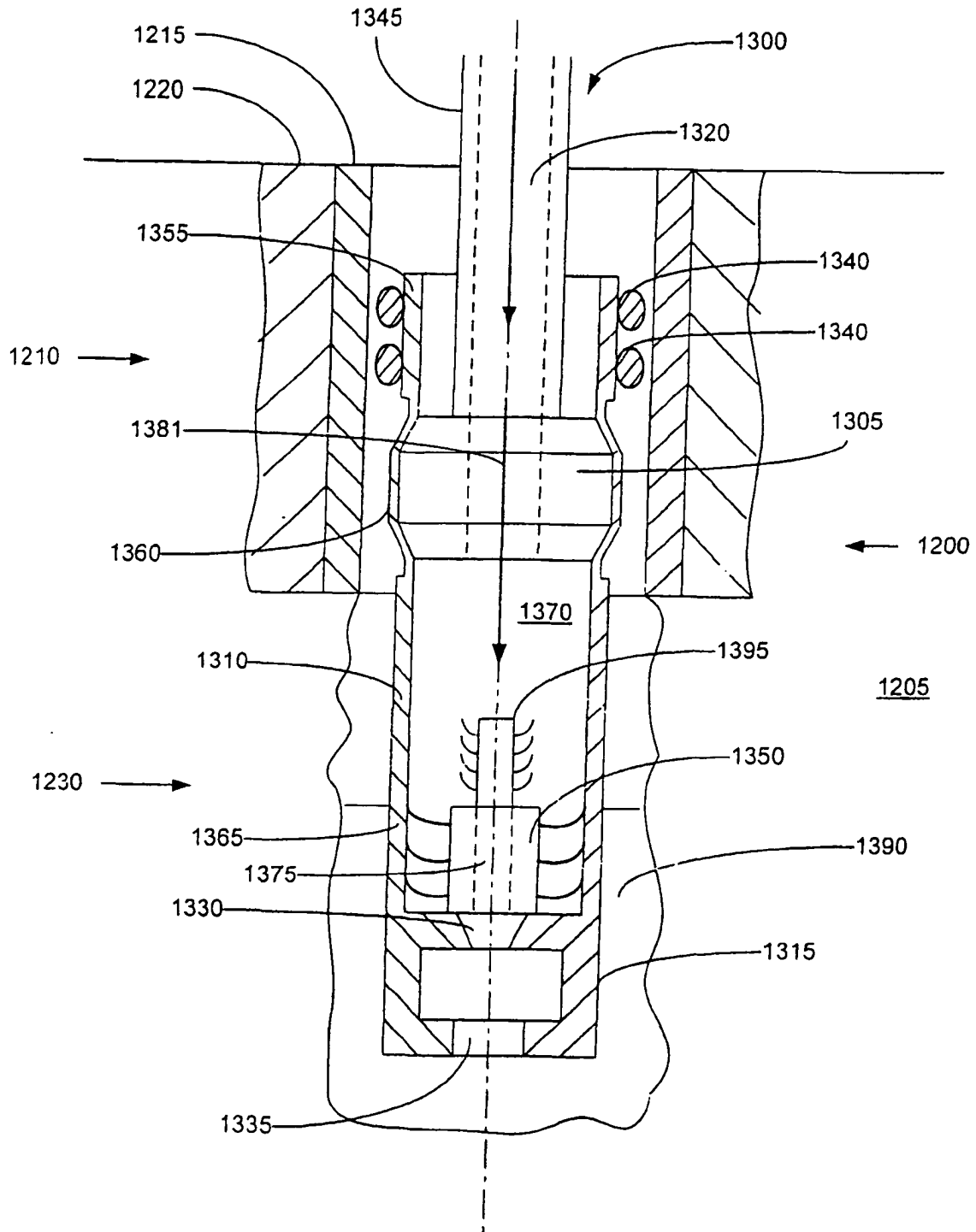

FIGURE 11e

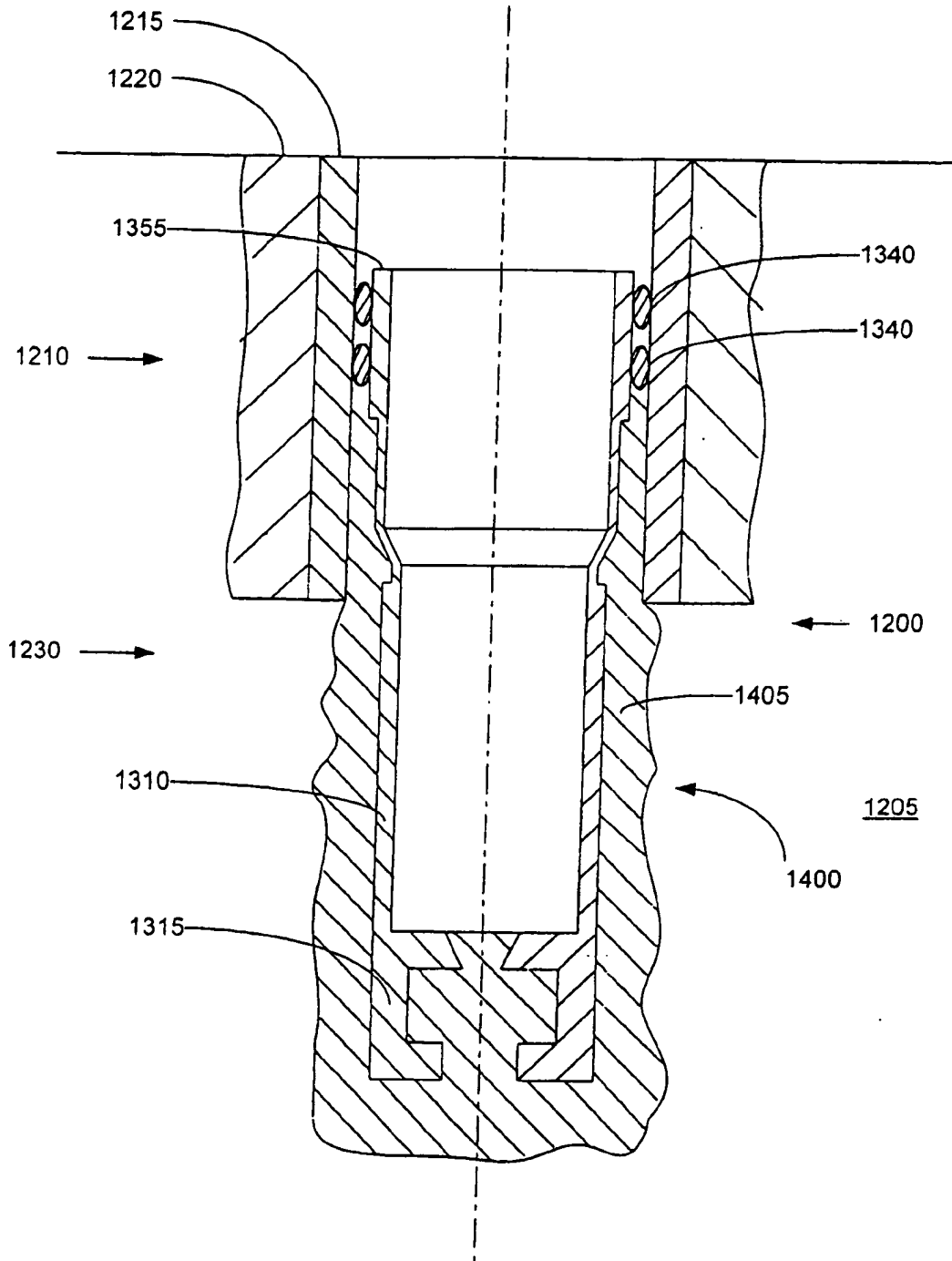

FIGURE 11f

27/47

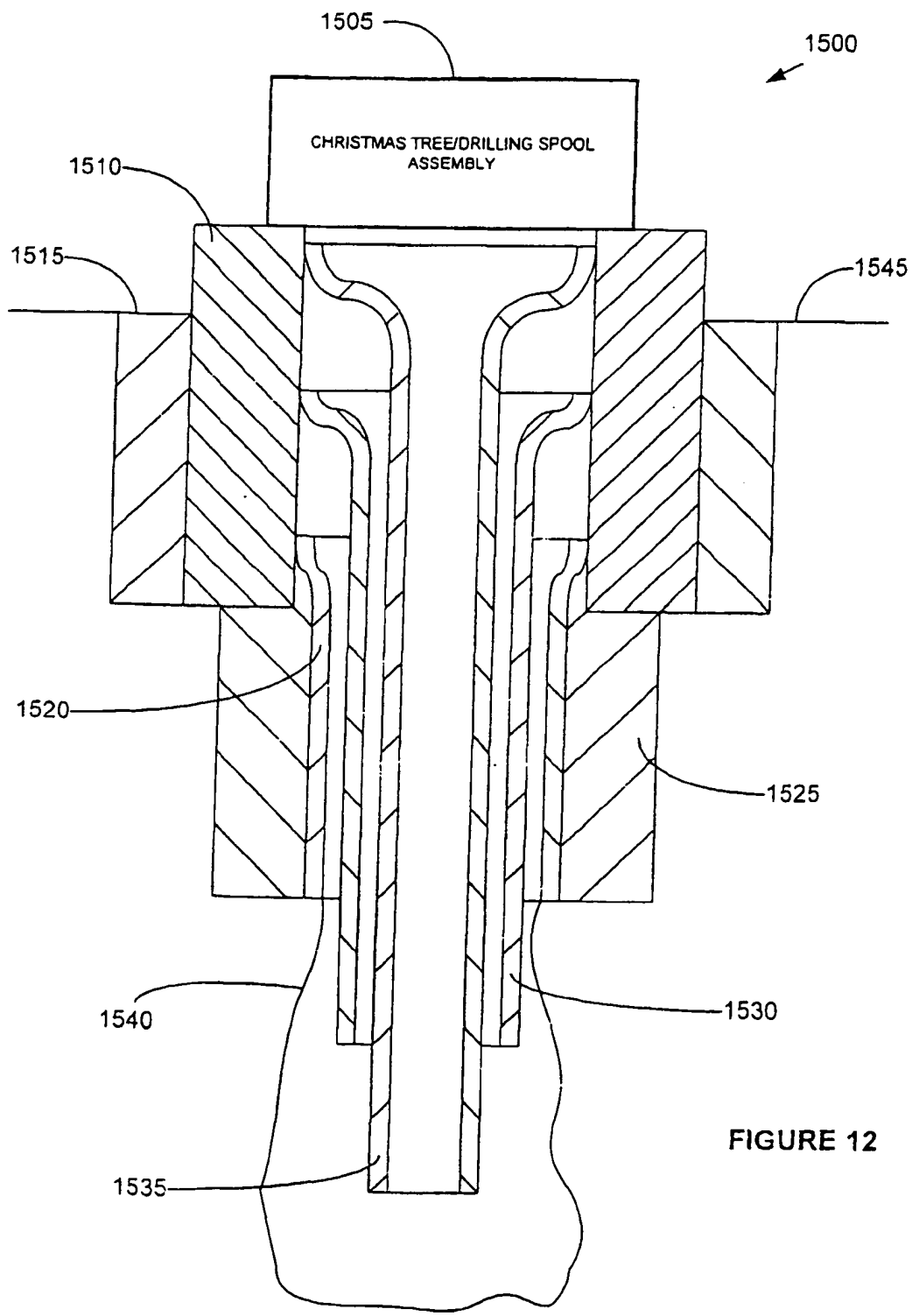

FIGURE 12



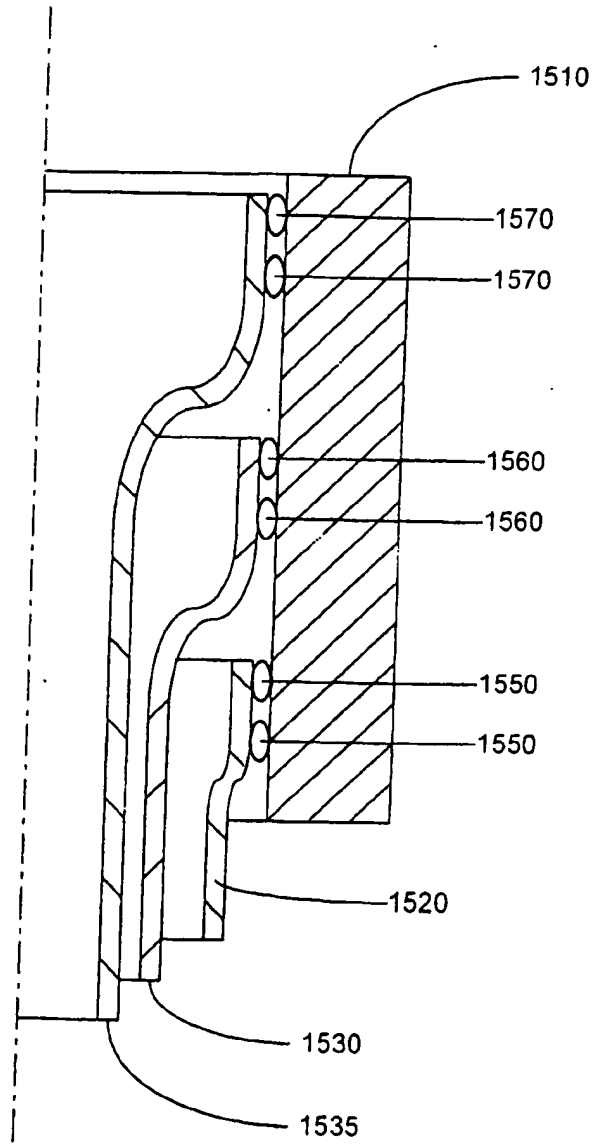

FIGURE 13

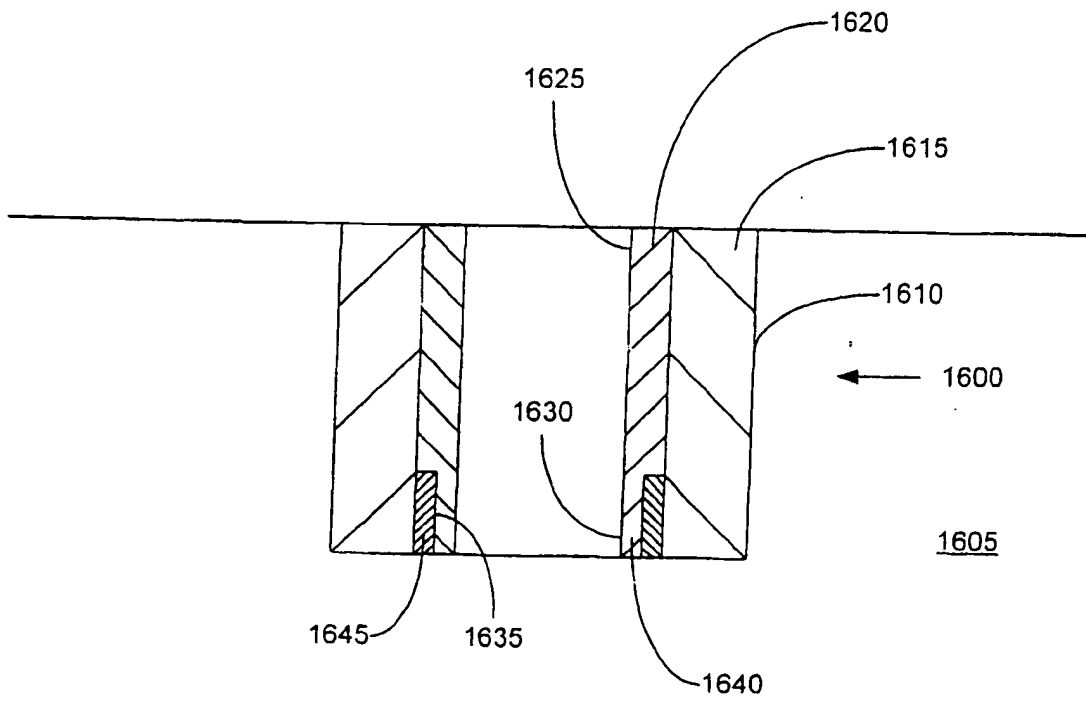

FIGURE 14a

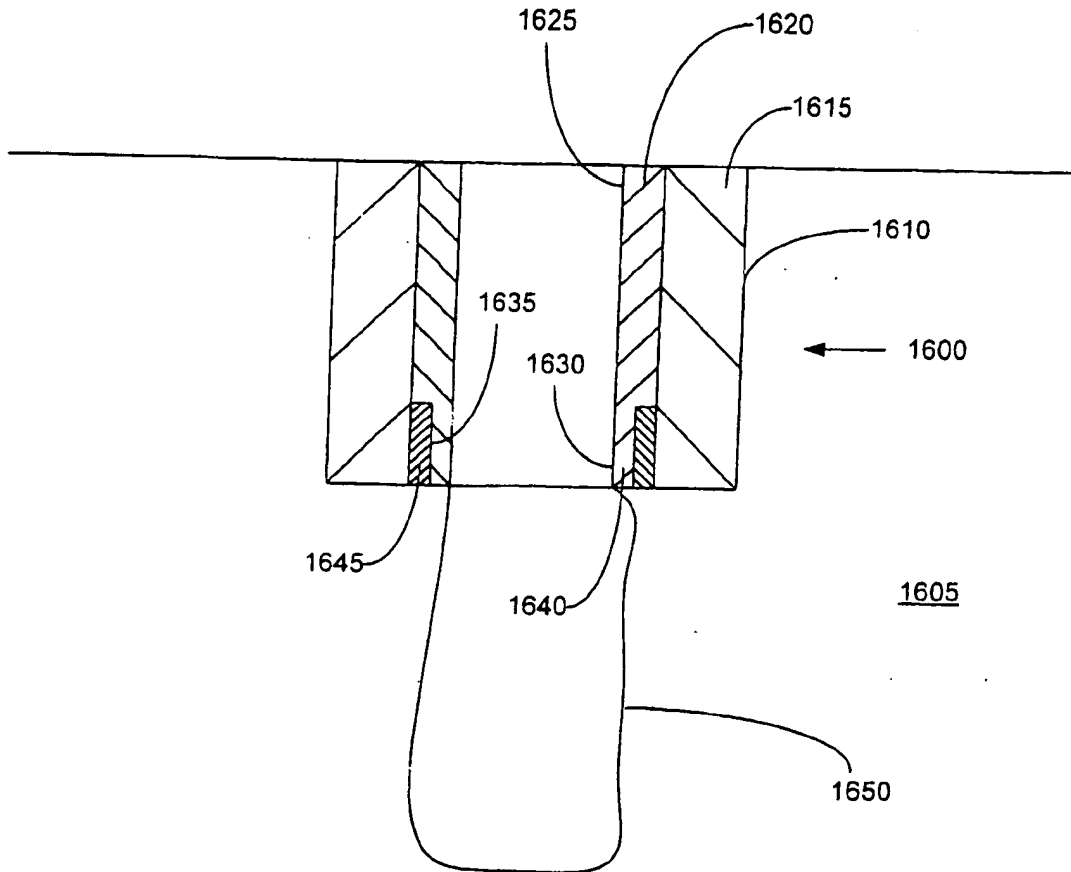

FIGURE 14b

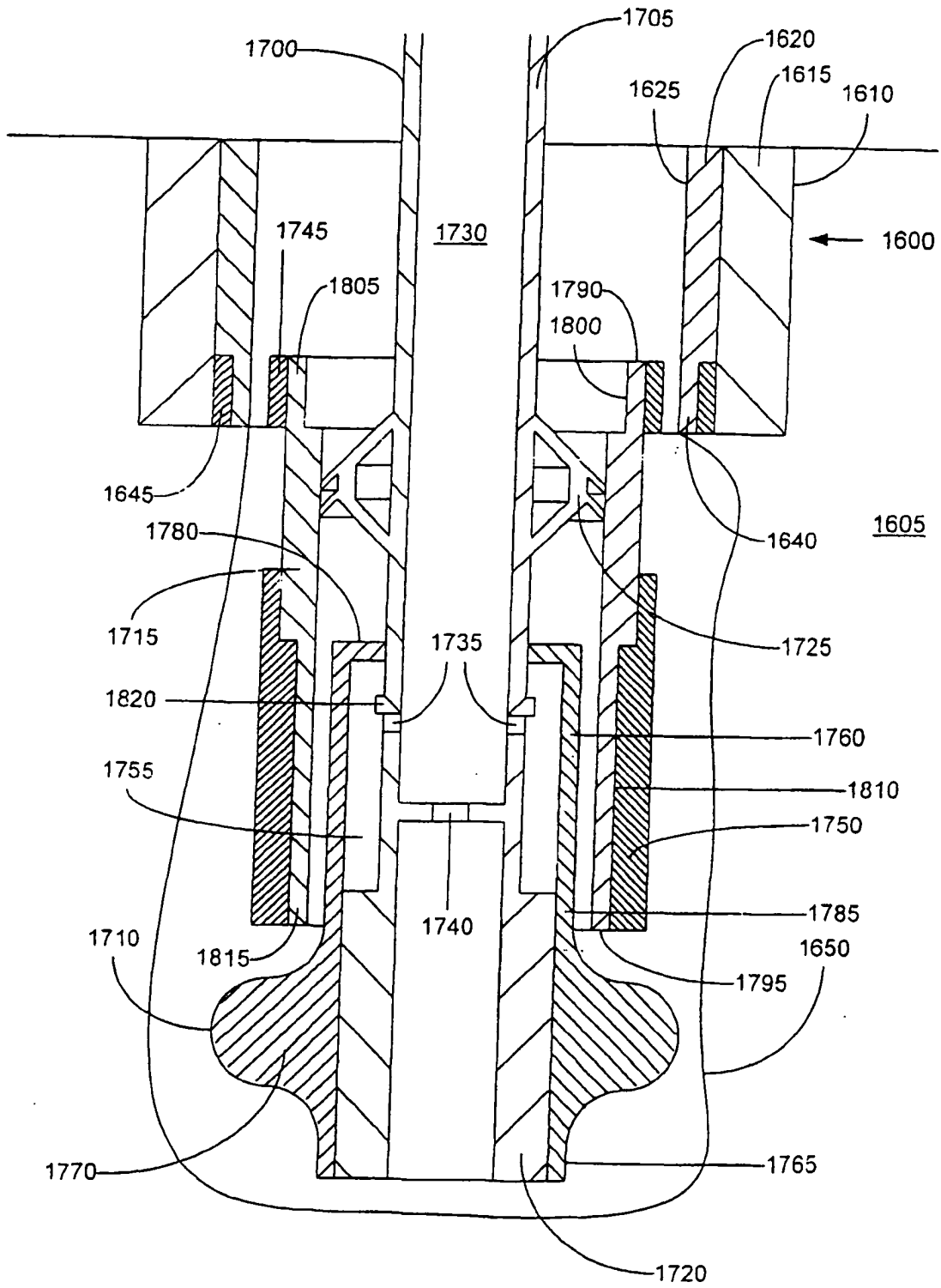

FIGURE 14c

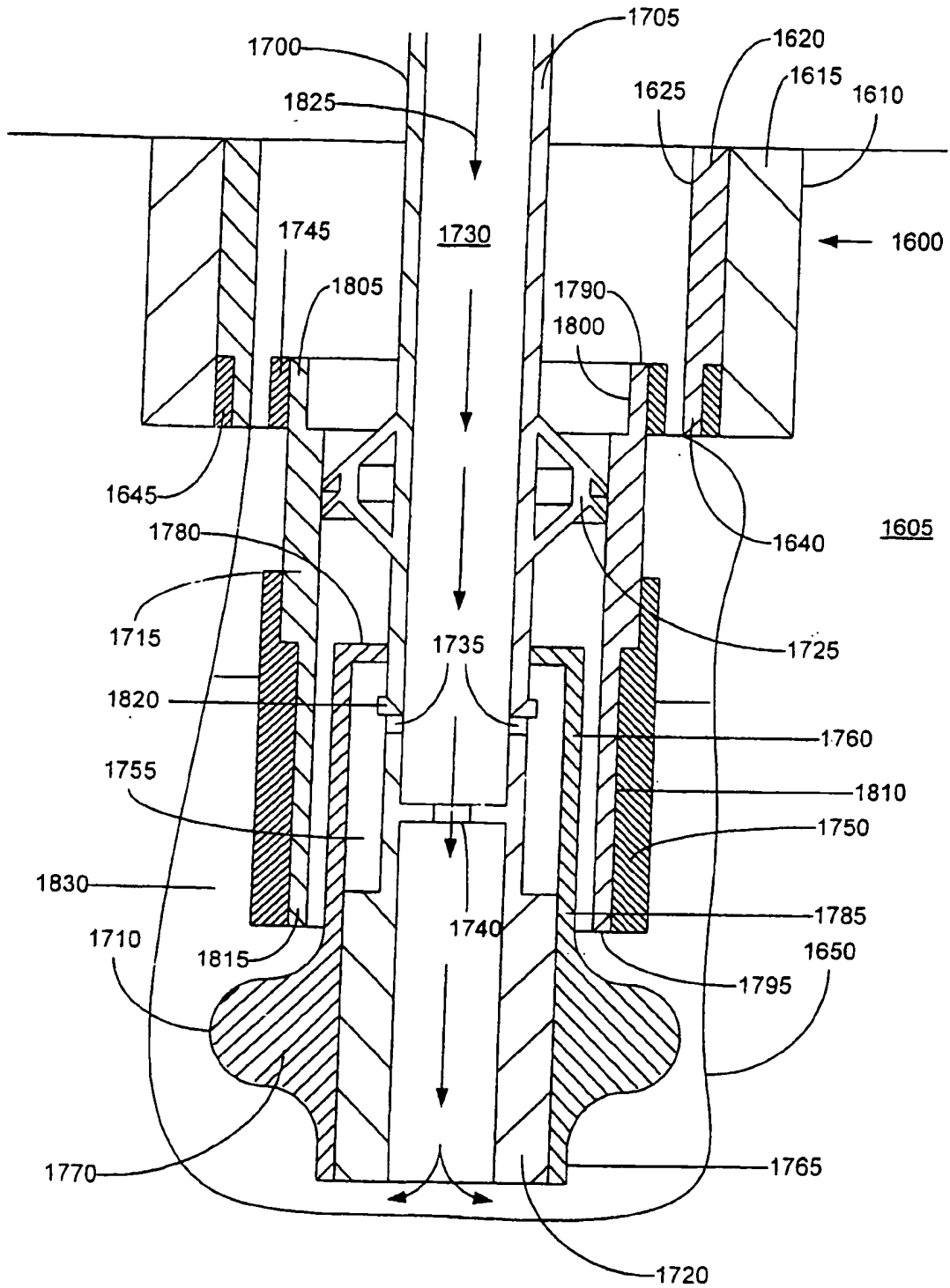

FIGURE 14d

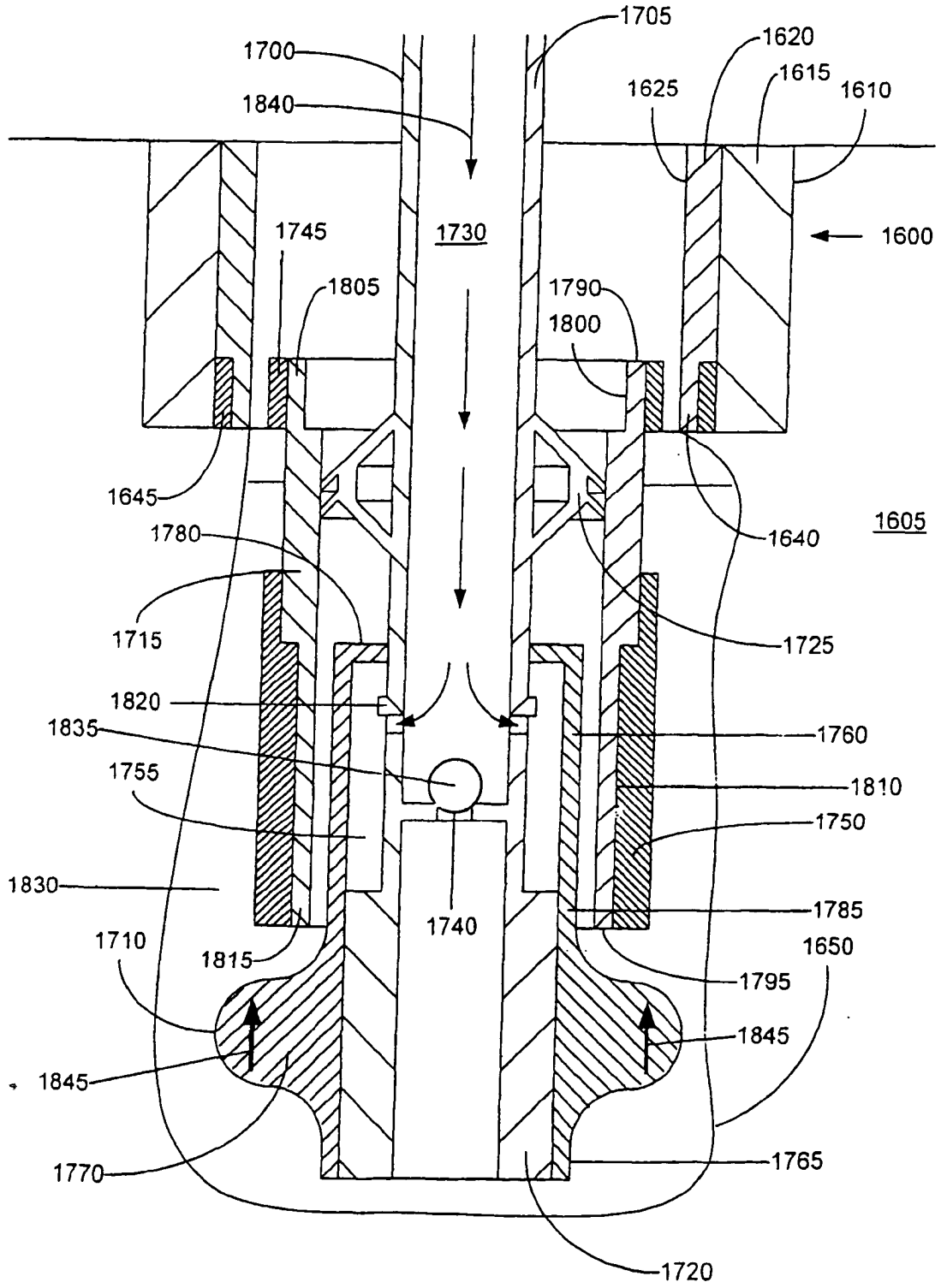

FIGURE 14e

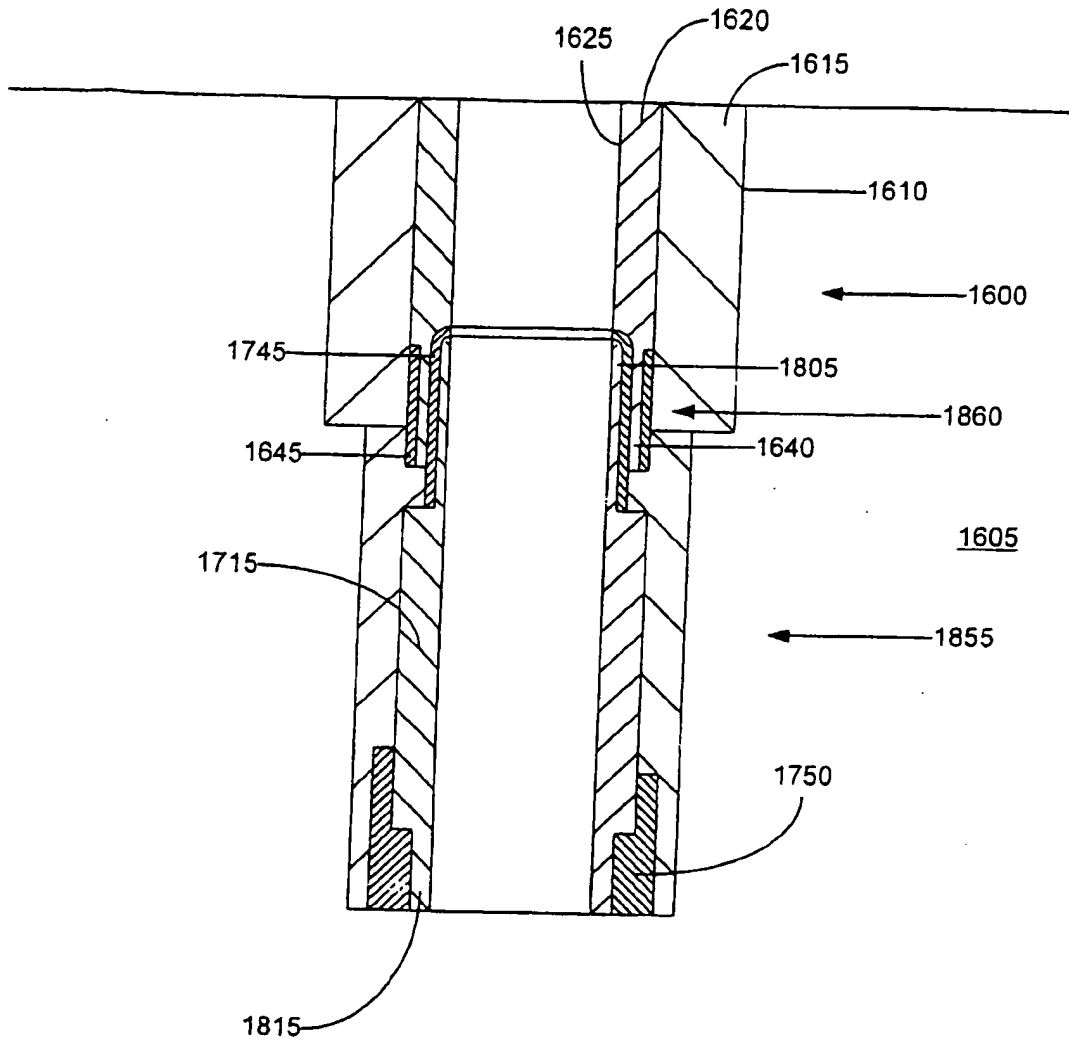

FIGURE 14f

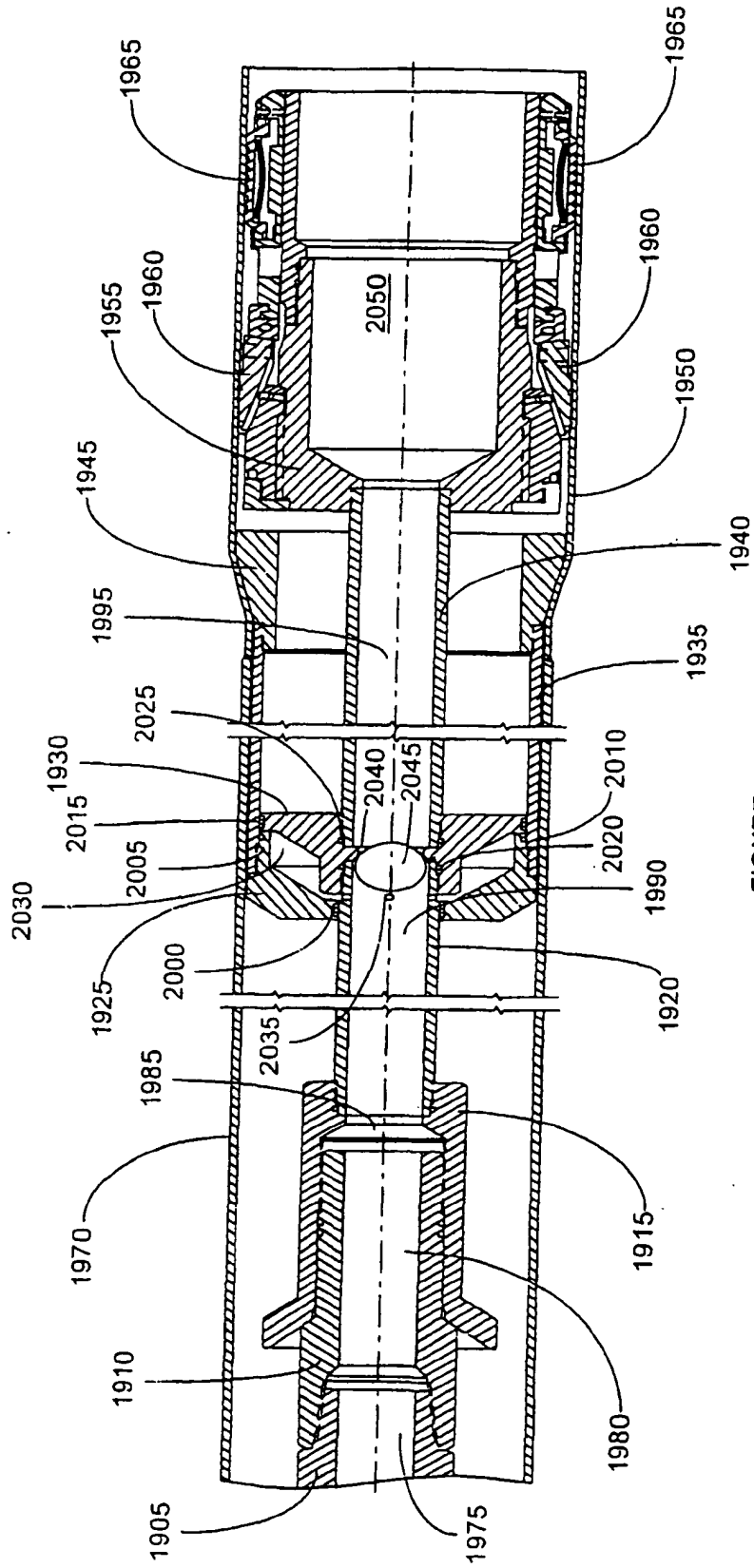

FIGURE 15



36/47

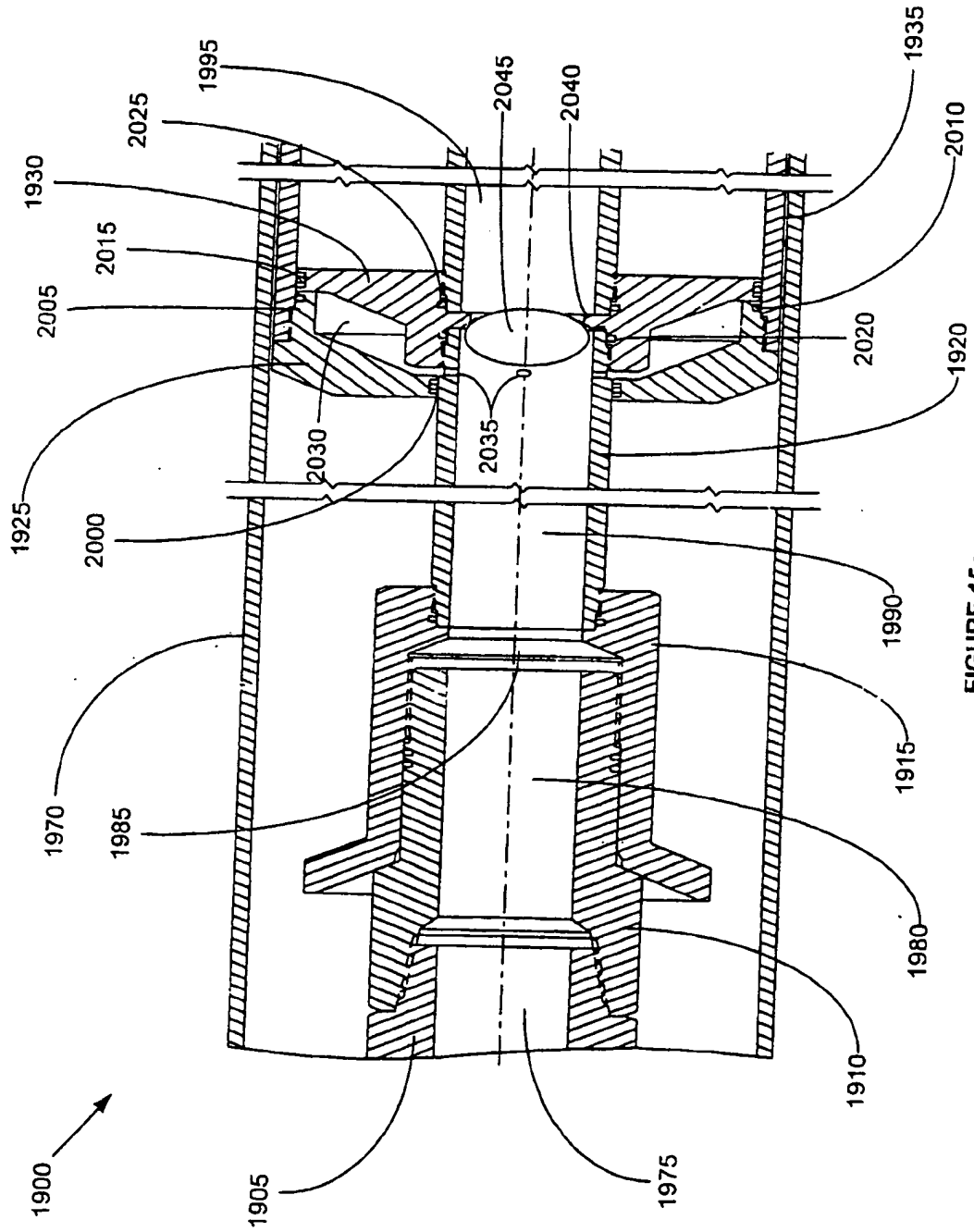

FIGURE 15a

37/47

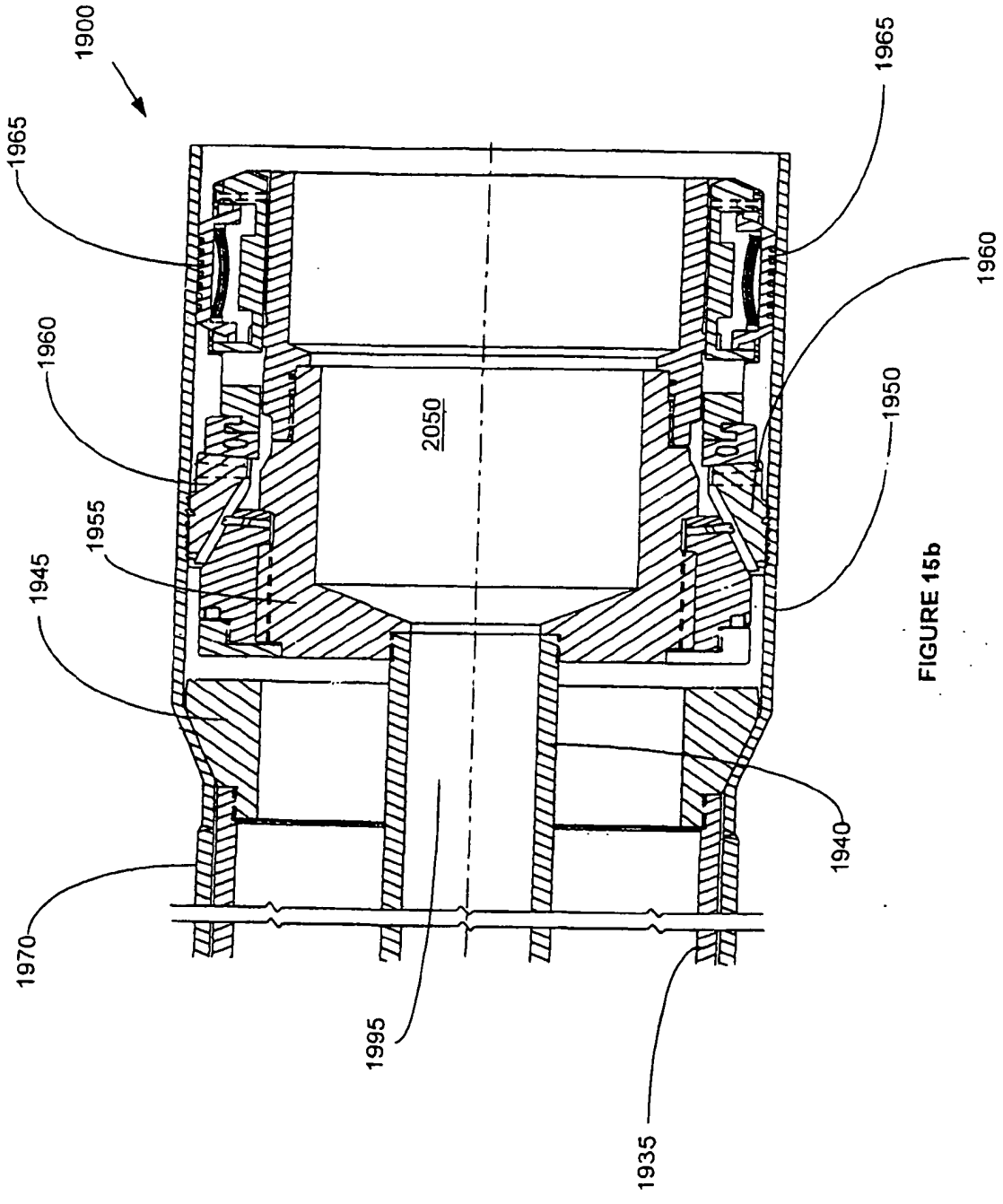
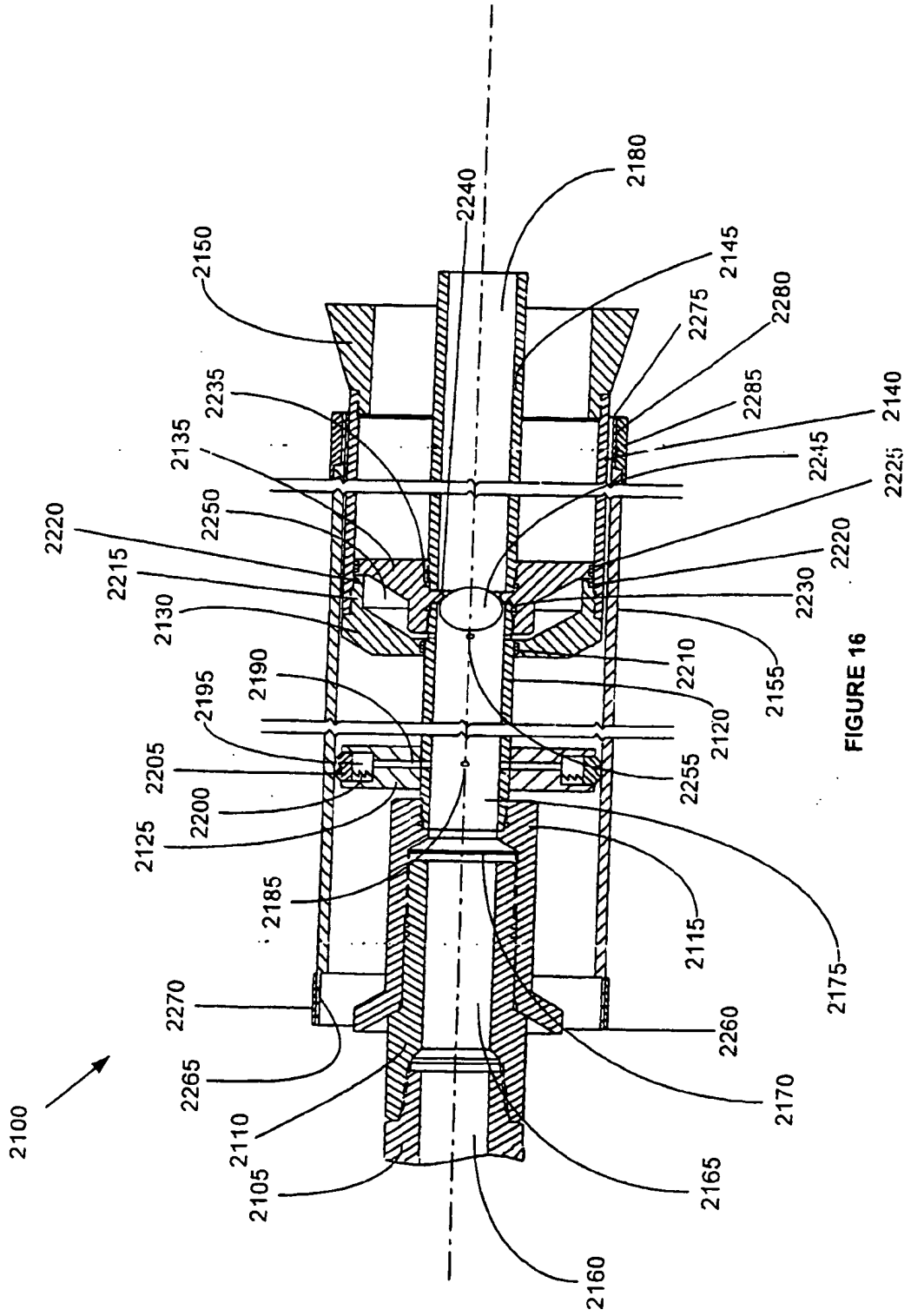

FIGURE 15b



39/47

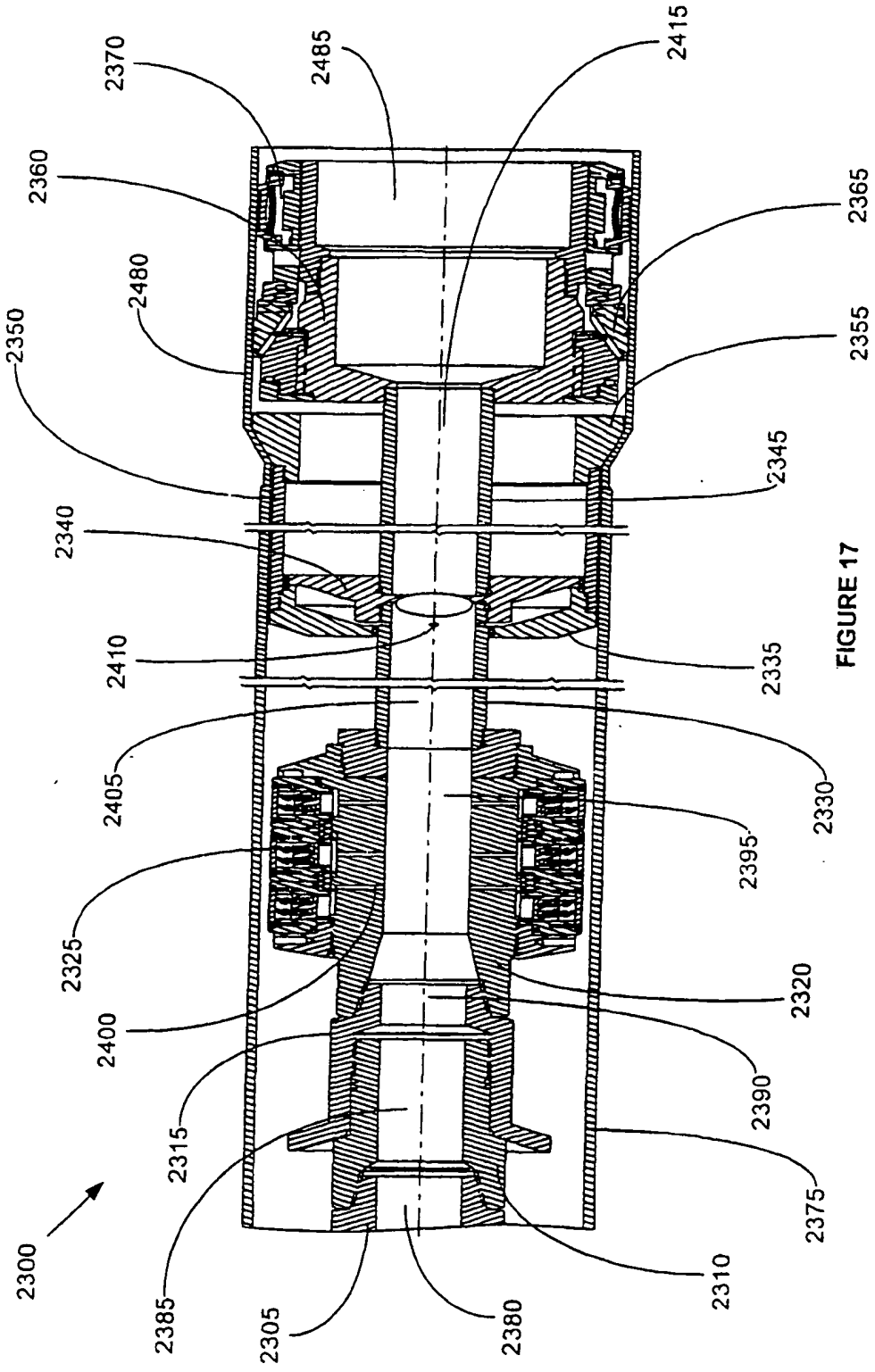

FIGURE 17

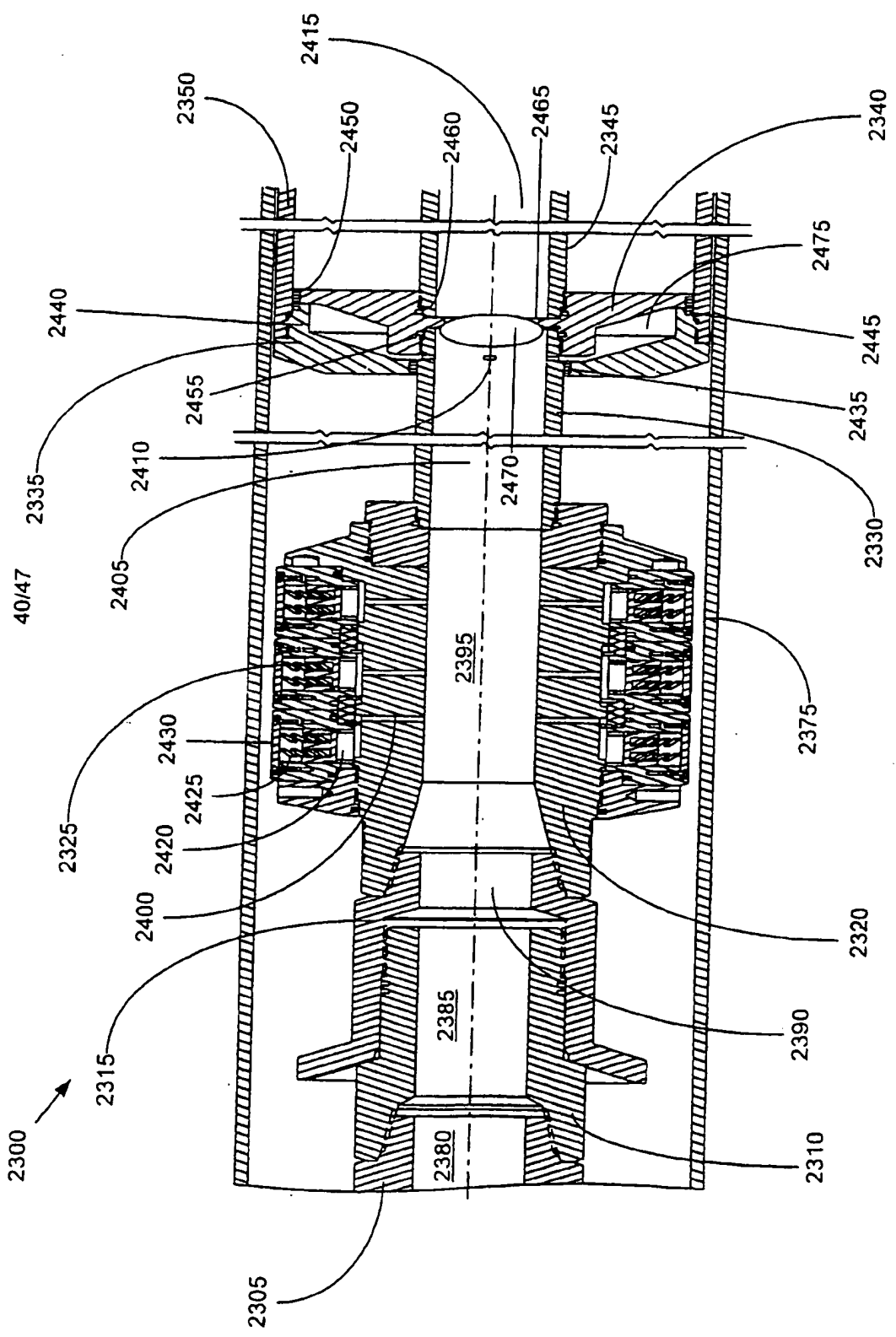

FIGURE 17a

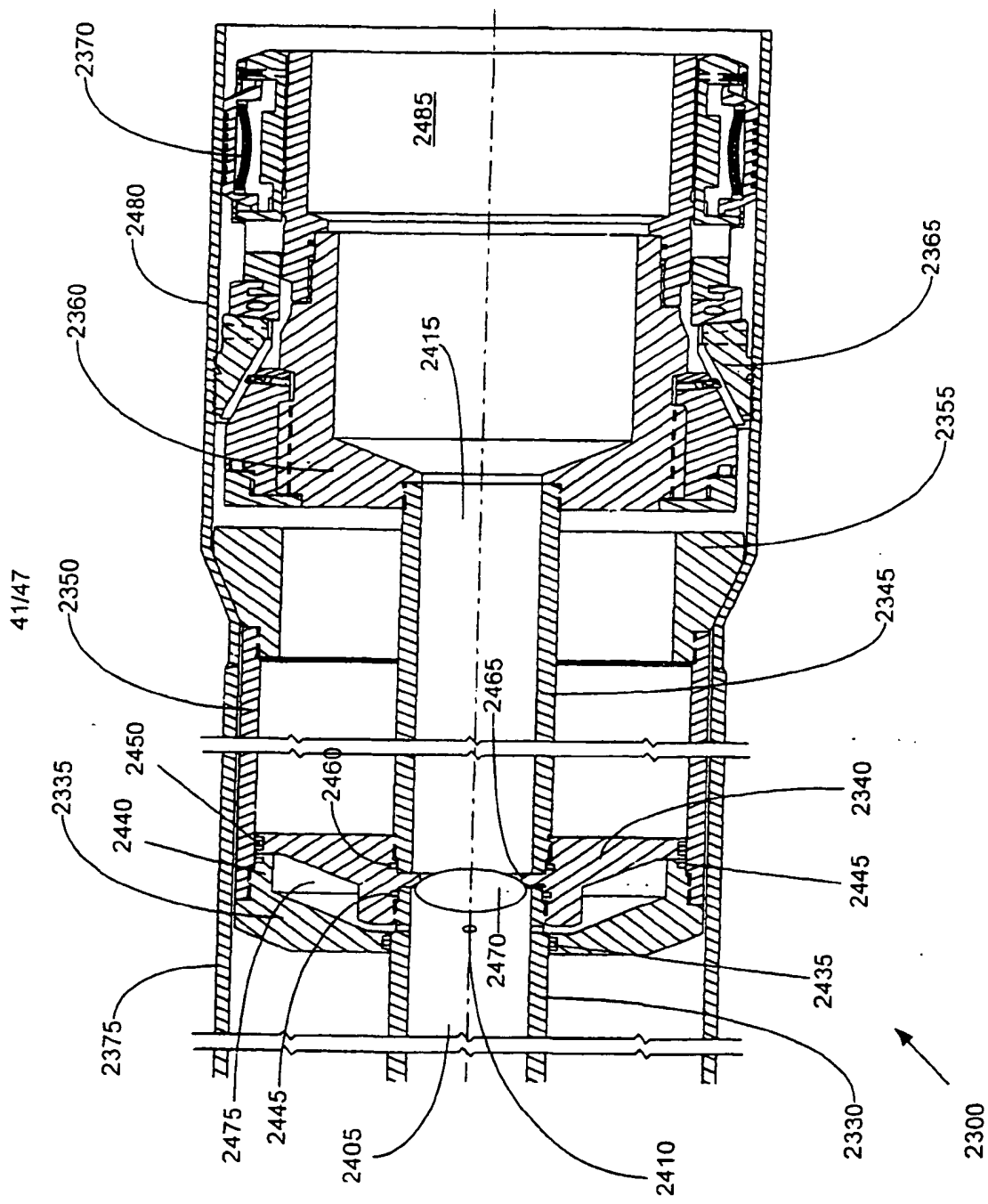

FIGURE 17b

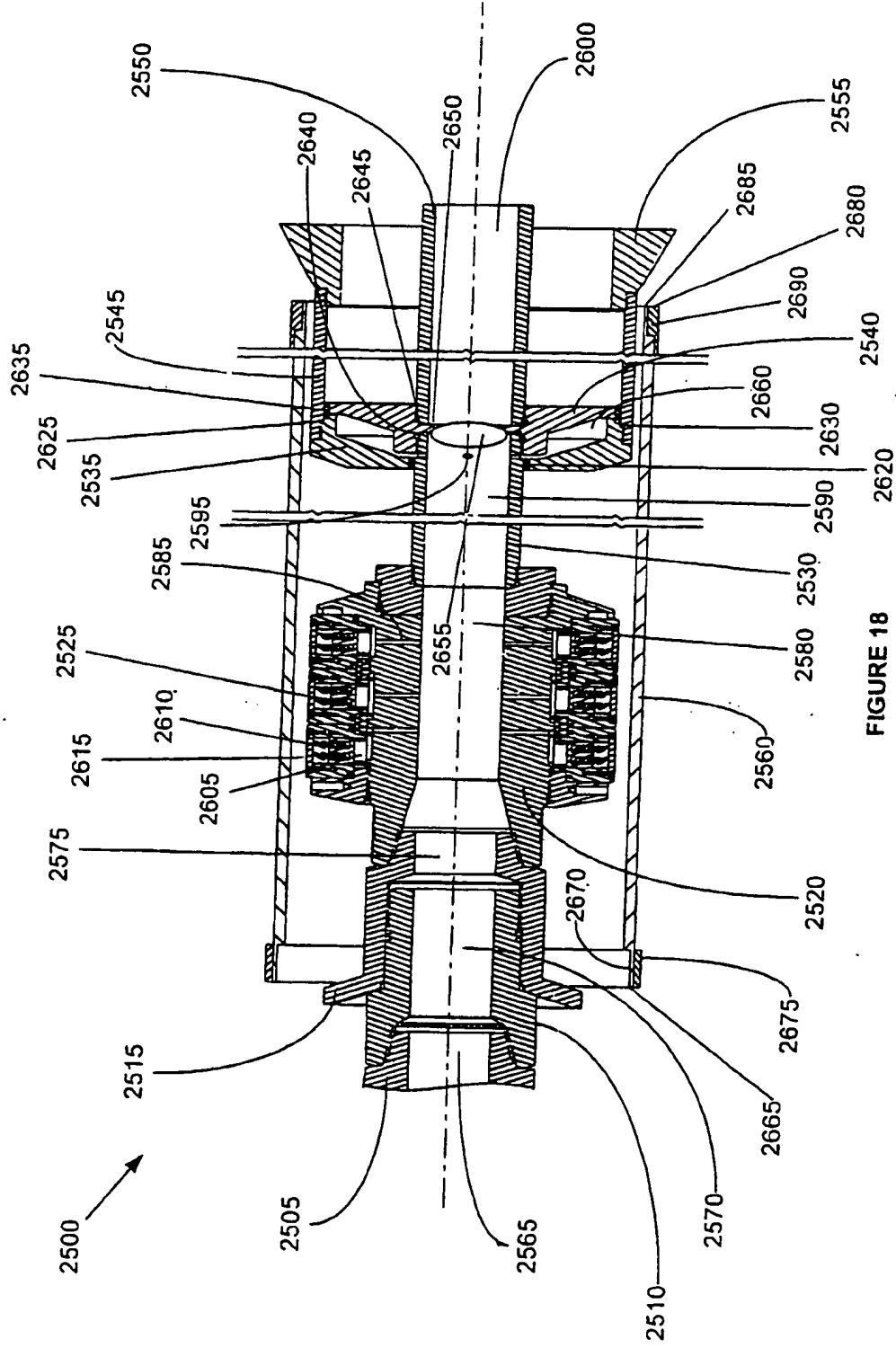

FIGURE 18

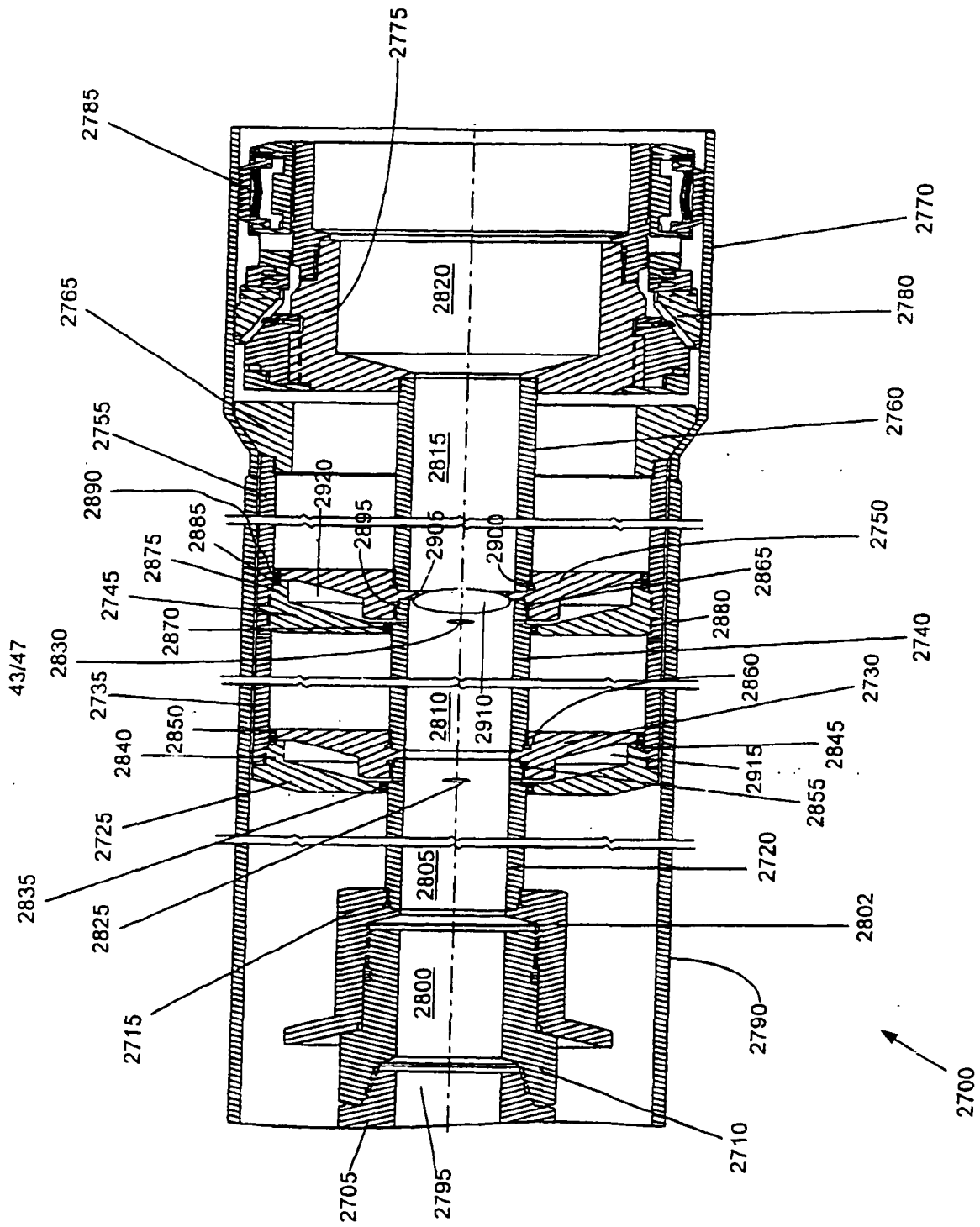

FIGURE 19



44/47

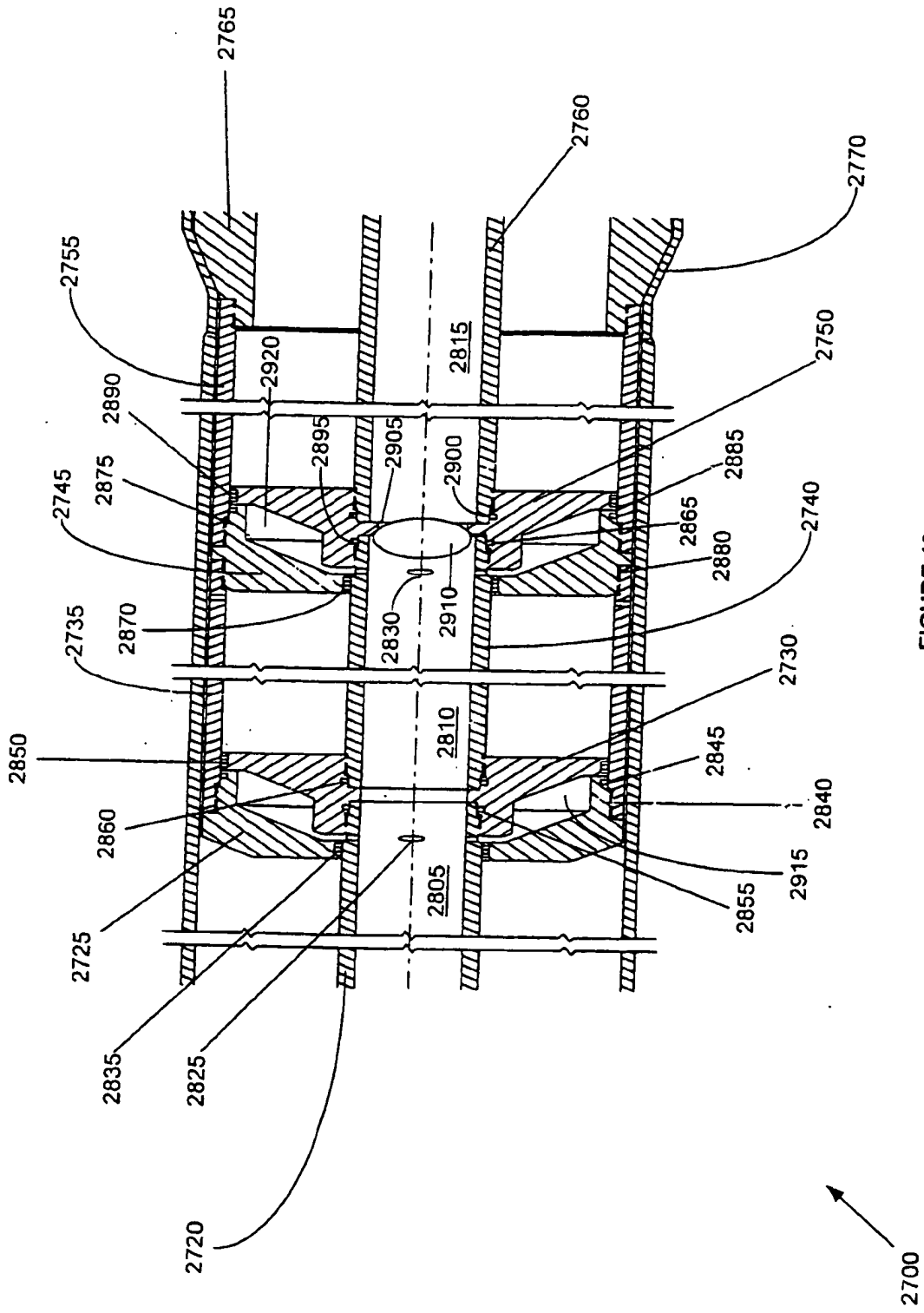

FIGURE 19a

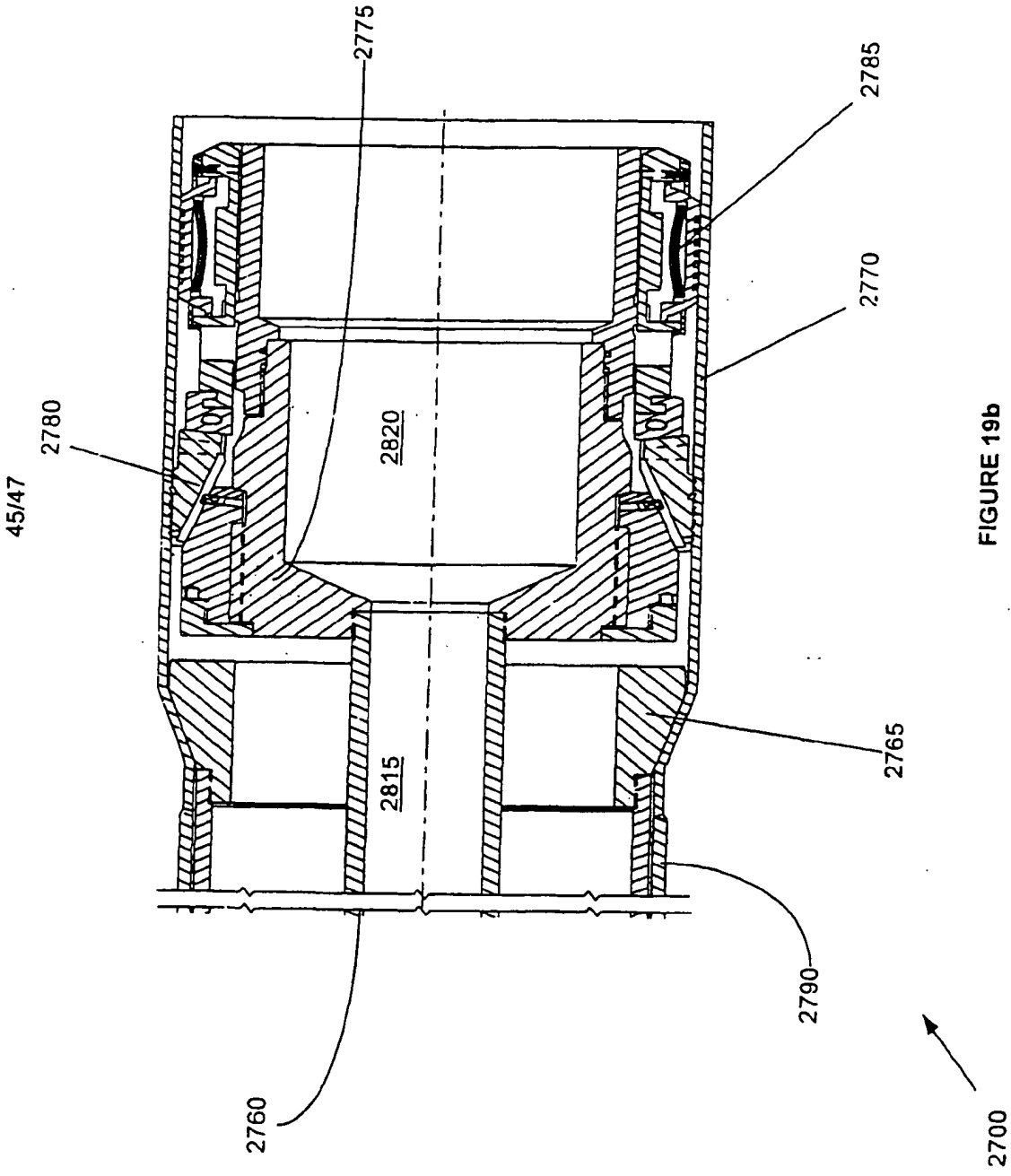

FIGURE 19b

2700

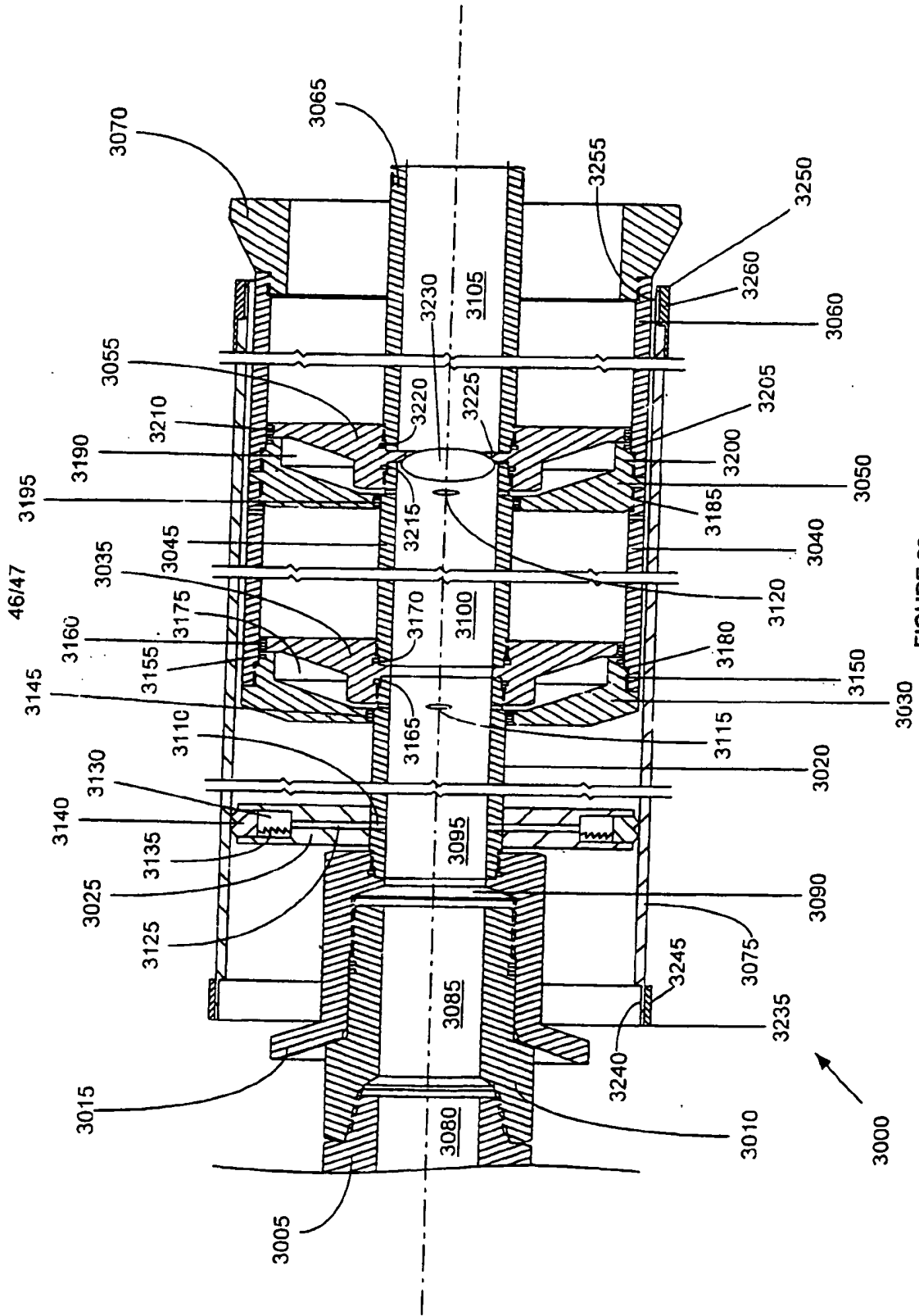

FIGURE 20

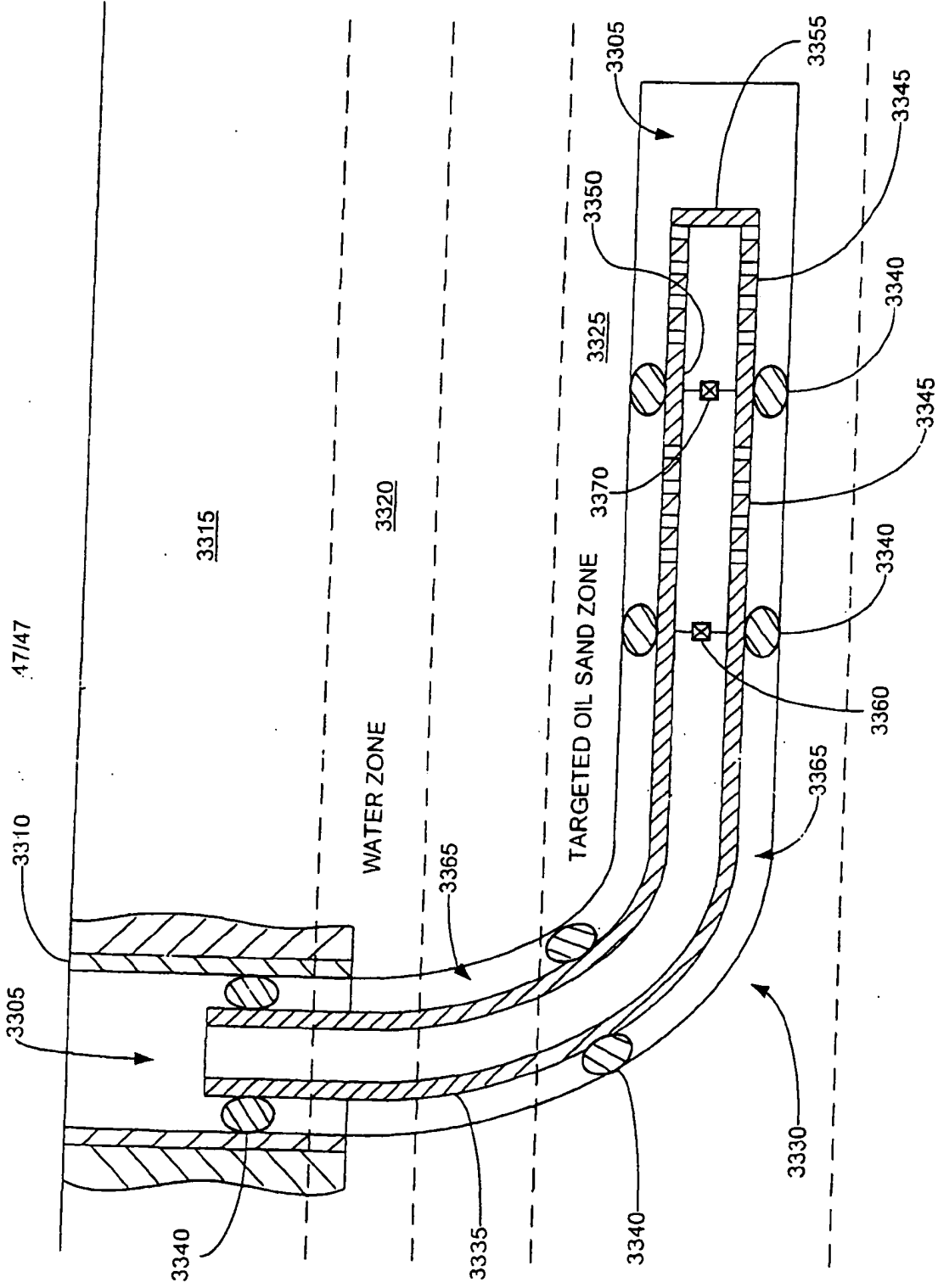

FIGURE 21

# A METHOD OF EXTRACTING MATERIALS FROM A WELLBORE

## Background of the Invention

This invention relates to a method of extracting materials from a wellbore.

5 Conventionally, when a wellbore is created, a number of casings are installed in the borehole to prevent collapse of the borehole wall and to prevent undesired outflow of drilling fluid into the formation or inflow of fluid from the formation into the borehole. The borehole is drilled in intervals whereby a casing which is to be installed in a lower borehole interval is lowered through a previously installed casing of an upper borehole interval. As a consequence of this procedure the casing of the lower interval is of smaller diameter than the casing of the upper interval. Thus, the casings are in a nested arrangement with casing diameters decreasing in downward direction. Cement annuli are provided between the outer surfaces of the casings and the borehole wall to seal the casings from the borehole wall. As a consequence of this nested arrangement a relatively large borehole diameter is required at the upper part of the wellbore. Such a large borehole diameter involves increased costs due to heavy casing handling equipment, large drill bits and increased volumes of drilling fluid and drill cuttings. Moreover, increased drilling rig time is involved due to required cement pumping, cement hardening, required equipment changes due to large variations in hole diameters drilled in the course of the well, and the large volume of cuttings drilled and removed.

15 Conventionally, at the surface end of the wellbore, a wellhead is formed that typically includes a surface casing, a number of production and/or drilling spools, valving, and a Christmas tree. Typically the wellhead further includes a concentric arrangement of casings including a production casing and one or more intermediate casings. The casings are typically supported using load bearing slips positioned above the ground. The conventional design and construction of wellheads is expensive and complex.

25 The present invention is directed to overcoming one or more of the limitations of the existing procedures for forming wellbores and wellheads.

30

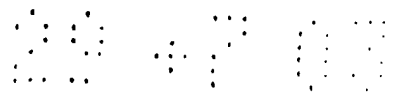

Summary of the Invention

According to the present invention, there is provided a method of extracting materials from a producing subterranean zone in a wellbore, at least a portion of the wellbore including a casing, comprising;

- 5       positioning one or more primary solid tubulars within the wellbore;
- fluidically coupling the primary solid tubulars with the casing;
- positioning one or more slotted tubulars within the wellbore, the slotted tubulars traversing the producing subterranean zone;
- plastically deforming at least some of the tubulars within the wellbore;
- 10       fluidically coupling the slotted tubulars with the solid tubulars;
- fluidically isolating the producing subterranean zone from at least one other subterranean zone within the wellbore;
- fluidically coupling at least one of the slotted tubulars from the producing subterranean zone;
- 15       overlapping at least some of the tubulars with other tubulars; and
- wherein the inside diameters of the non-overlapping portions of the overlapping tubulars are substantially equal.

Preferably, a seal is provided at an interface between the one or more primary solid tubulars and the one or more slotted tubulars.

20       Preferably, a sealed is placed at an interface between the one or more primary solid tubulars and the one or more slotted tubulars.

Preferably, the seal comprises a compressible annular body.

Preferably, at least one of the one or more primary solid tubulars comprises a thin - wall end portion.

25       Preferably, at least one of the one or more slotted tubulars comprises a thin - wall end portion.

Preferably, an interface is provided between two adjacent thin - wall end portions.

Preferably, a seal is provided at said interface.

30       Preferably, the seal comprises a compressible annular body.

Preferably, the plastically deforming at least some of the tubulars comprises

plastically deforming at least two thin - wall end portions.

### Brief Description of the Drawings

For a better understanding of the present invention, and to show how it may be carried into effect, reference will now be made, by way of example, to the accompanying drawings in which:

FIG. 1 is a fragmentary cross-sectional view illustrating the drilling of a new section of a well borehole.

FIG. 2 is a fragmentary cross-sectional view illustrating the placement of an apparatus for creating a casing within the new section of the well borehole.

FIG. 3 is a fragmentary cross-sectional view illustrating the injection of a first quantity of a fluidic material into the new section of the well borehole.

FIG. 3a is another fragmentary cross-sectional view illustrating the injection of a first quantity of a hardenable fluidic sealing material into the new section of the well borehole.

FIG. 4 is a fragmentary cross-sectional view illustrating the injection of a second quantity of a fluidic material into the new section of the well borehole.

FIG. 5 is a fragmentary cross-sectional view illustrating the drilling out of a portion of the cured hardenable fluidic sealing material from the new section of the well borehole.

FIG. 6 is a cross-sectional view of the overlapping joint between adjacent tubular members.

FIG. 7 is a fragmentary cross-sectional view of the apparatus for creating a casing within a well borehole.

FIG. 8 is a fragmentary cross-sectional illustration of the placement of an expanded tubular member within another tubular member.

FIG. 9 is a cross-sectional illustration of an apparatus for forming a casing including a drillable mandrel and shoe.

FIG. 9a is another cross-sectional illustration of the apparatus of FIG. 9.

FIG. 9b is another cross-sectional illustration of the apparatus of FIG. 9.

FIG. 9c is another cross-sectional illustration of the apparatus of FIG. 9.

FIG. 10a is a cross-sectional illustration of a wellbore including a pair of adjacent overlapping casings.

FIG. 10b is a cross-sectional illustration of an apparatus and method for creating a tie-back liner using an expandible tubular member.

5 FIG. 10c is a cross-sectional illustration of the pumping of a fluidic sealing material into the annular region between the tubular member and the existing casing.

FIG. 10d is a cross-sectional illustration of the pressurizing of the interior of the tubular member below the mandrel.

10 FIG. 10e is a cross-sectional illustration of the extrusion of the tubular member off of the mandrel.

FIG. 10f is a cross-sectional illustration of the tie-back liner before drilling out the shoe and packer.

FIG. 10g is a cross-sectional illustration of the completed tie-back liner created using an expandible tubular member.

15 FIG. 11a is a fragmentary cross-sectional view illustrating the drilling of a new section of a well borehole.

FIG. 11b is a fragmentary cross-sectional view illustrating the placement of an apparatus for hanging a tubular liner within the new section of the well borehole.

20 FIG. 11c is a fragmentary cross-sectional view illustrating the injection of a first quantity of a hardenable fluidic sealing material into the new section of the well borehole.

FIG. 11d is a fragmentary cross-sectional view illustrating the introduction of a wiper dart into the new section of the well borehole.

25 FIG. 11e is a fragmentary cross-sectional view illustrating the injection of a second quantity of a hardenable fluidic sealing material into the new section of the well borehole.

FIG. 11f is a fragmentary cross-sectional view illustrating the completion of the tubular liner.

30 FIG. 12 is a cross-sectional illustration of a wellhead system utilizing expandable tubular members.

FIG. 13 is a partial cross-sectional illustration of the wellhead system of FIG. 12.



FIG. 14a is an illustration of the formation of a mono-diameter wellbore casing.

FIG. 14b is another illustration of the formation of the mono-diameter wellbore casing.

5 FIG. 14c is another illustration of the formation of the mono-diameter wellbore casing.

FIG. 14d is another illustration of the formation of the mono-diameter wellbore casing.

FIG. 14e is another illustration of the formation of the mono-diameter wellbore casing.

10 FIG. 14f is another illustration of the formation of the mono-diameter wellbore casing.

FIG. 15 is an illustration of an apparatus for expanding a tubular member.

FIG. 15a is another illustration of the apparatus of FIG. 15.

FIG. 15b is another illustration of the apparatus of FIG. 15.

15 FIG. 16 is an illustration of an apparatus for forming a mono-diameter wellbore casing.

FIG. 17 is an illustration of an apparatus for expanding a tubular member.

FIG. 17a is another illustration of the apparatus of FIG. 16.

FIG. 17b is another illustration of the apparatus of FIG. 16.

20 FIG. 18 is an illustration of an apparatus for forming a mono-diameter wellbore casing.

FIG. 19 is an illustration of an apparatus for expanding a tubular member.

FIG. 19a is another illustration of the apparatus of FIG. 17.

FIG. 19b is another illustration of the apparatus of FIG. 17.

25 FIG. 20 is an illustration of an apparatus for forming a mono-diameter wellbore casing.

FIG. 21 is an illustration of the isolation of subterranean zones using expandable tubulars.

#### Detailed Description of the Illustrative Embodiments

30 Referring initially to Figs. 1-5, an apparatus and method for forming a wellbore casing within a subterranean formation will now be described. As illustrated in Fig. 1, a wellbore 100 is positioned in a subterranean formation 105. The wellbore 100

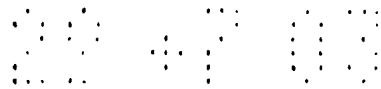

includes an existing cased section 110 having a tubular casing 115 and an annular outer layer of cement 120.

In order to extend the wellbore 100 into the subterranean formation 105, a drill string 125 is used in a well known manner to drill out material from the subterranean formation 105 to form a new section 130.

As illustrated in Fig. 2, an apparatus 200 for forming a wellbore casing in a subterranean formation is then positioned in the new section 130 of the wellbore 100. The apparatus 200 preferably includes an expandable mandrel or pig 205, a tubular member 210, a shoe 215, a lower cup seal 220, an upper cup seal 225, a fluid passage 230, a fluid passage 235, a fluid passage 240, seals 245, and a support member 250.

The expandable mandrel 205 is coupled to and supported by the support member 250. The expandable mandrel 205 is preferably adapted to controllably expand in a radial direction. The expandable mandrel 205 may comprise any number of conventional commercially available expandable mandrels modified in accordance with the teachings of the present disclosure. The expandable mandrel 205 comprises a hydraulic expansion tool as disclosed in U.S. Patent No. 5,348,095, the contents of which are incorporated herein by reference, modified in accordance with the teachings of the present disclosure.

The tubular member 210 is supported by the expandable mandrel 205. The tubular member 210 is expanded in the radial direction and extruded off of the expandable mandrel 205. The tubular member 210 may be fabricated from any number of conventional commercially available materials such as, for example, Oilfield Country Tubular Goods (OCTG), 13 chromium steel tubing/casing, or plastic tubing/casing. The tubular member 210 is fabricated from OCTG in order to maximize strength after expansion. The inner and outer diameters of the tubular member 210 may range, for example, from approximately 0.75 to 47 inches and 1.05 to 48 inches, respectively. The inner and outer diameters of the tubular member 210 range from about 3 to 15.5 inches and 3.5 to 16 inches, respectively in order to optimally provide minimal telescoping effect in the most commonly drilled wellbore sizes. The tubular member 210 preferably comprises a solid member.

The end portion 260 of the tubular member 210 is slotted, perforated, or otherwise modified to catch or slow down the mandrel 205 when it completes the

extrusion of tubular member 210. The length of the tubular member 210 is limited to minimize the possibility of buckling. For typical tubular member 210 materials, the length of the tubular member 210 is preferably limited to between about 40 to 20,000 feet in length.

5           The shoe 215 is coupled to the expandable mandrel 205 and the tubular member 210. The shoe 215 includes fluid passage 240. The shoe 215 may comprise any number of conventional commercially available shoes such as, for example, Super Seal II float shoe, Super Scal II Down-Jet float shoe or a guide shoe with a sealing sleeve for a latch down plug modified in accordance with the teachings of the present  
10 disclosure. The shoe 215 comprises an aluminum down-jet guide shoe with a sealing sleeve for a latch-down plug available from Halliburton Energy Services in Dallas, TX, modified in accordance with the teachings of the present disclosure, in order to optimally guide the tubular member 210 in the wellbore, optimally provide an adequate seal between the interior and exterior diameters of the overlapping joint  
15 between the tubular members, and to optimally allow the complete drill out of the shoe and plug after the completion of the cementing and expansion operations.

          The shoe 215 includes one or more through and side outlet ports in fluidic communication with the fluid passage 240. In this manner, the shoe 215 optimally injects hardenable fluidic sealing material into the region outside the shoe 215 and  
20 tubular member 210. The shoe 215 includes the fluid passage 240 having an inlet geometry that can receive a dart and/or a ball sealing member. In this manner, the fluid passage 240 can be optimally scaled off by introducing a plug, dart and/or ball sealing elements into the fluid passage 230.

          The lower cup seal 220 is coupled to and supported by the support member 250.  
25           The lower cup seal 220 prevents foreign materials from entering the interior region of the tubular member 210 adjacent to the expandable mandrel 205. The lower cup seal 220 may comprise any number of conventional commercially available cup seals such as, for example, TP cups, or Selective Injection Packer (SIP) cups modified in accordance with the teachings of the present disclosure. The lower cup seal 220  
30 comprises a SIP cup seal, available from Halliburton Energy Services in Dallas, TX in order to optimally block foreign material and contain a body of lubricant.

20 47 00

5 The upper cup seal 225 is coupled to and supported by the support member 250. The upper cup seal 225 prevents foreign materials from entering the interior region of the tubular member 210. The upper cup seal 225 may comprise any number of conventional commercially available cup seals such as, for example, TP cups or SIP cups modified in accordance with the teachings of the present disclosure. The upper cup seal 225 comprises a SIP cup, available from Halliburton Energy Services in Dallas, TX in order to optimally block the entry of foreign materials and contain a body of lubricant.

10 The fluid passage 230 permits fluidic materials to be transported to and from the interior region of the tubular member 210 below the expandable mandrel 205. The fluid passage 230 is coupled to and positioned within the support member 250 and the expandable mandrel 205. The fluid passage 230 preferably extends from a position adjacent to the surface to the bottom of the expandable mandrel 205. The fluid passage 230 is preferably positioned along a centerline of the apparatus 200.

15 The fluid passage 230 is preferably selected, in the casing running mode of operation, to transport materials such as drilling mud or formation fluids at flow rates and pressures ranging from about 0 to 3,000 gallons/minute and 0 to 9,000 psi in order to minimize drag on the tubular member being run and to minimize surge pressures exerted on the wellbore which could cause a loss of wellbore fluids and lead to hole collapse.

20 The fluid passage 235 permits fluidic materials to be released from the fluid passage 230. In this manner, during placement of the apparatus 200 within the new section 130 of the wellbore 100, fluidic materials 255 forced up the fluid passage 230 can be released into the wellbore 100 above the tubular member 210 thereby minimizing surge pressures on the wellbore section 130. The fluid passage 235 is coupled to and positioned within the support member 250. The fluid passage is further fluidically coupled to the fluid passage 230.

25 The fluid passage 235 preferably includes a control valve for controllably opening and closing the fluid passage 235. The control valve is pressure activated in order to controllably minimize surge pressures. The fluid passage 235 is preferably positioned substantially orthogonal to the centerline of the apparatus 200.

The fluid passage 235 is preferably selected to convey fluidic materials at flow rates and pressures ranging from about 0 to 3,000 gallons/minute and 0 to 9,000 psi in order to reduce the drag on the apparatus 200 during insertion into the new section 130 of the wellbore 100 and to minimize surge pressures on the new wellbore section 130.

5 The fluid passage 240 permits fluidic materials to be transported to and from the region exterior to the tubular member 210 and shoe 215. The fluid passage 240 is coupled to and positioned within the shoe 215 in fluidic communication with the interior region of the tubular member 210 below the expandable mandrel 205. The fluid passage 240 preferably has a cross-sectional shape that permits a plug, or other  
10 similar device, to be placed in fluid passage 240 to thereby block further passage of fluidic materials. In this manner, the interior region of the tubular member 210 below the expandable mandrel 205 can be fluidically isolated from the region exterior to the tubular member 210. This permits the interior region of the tubular member 210 below the expandable mandrel 205 to be pressurized. The fluid passage 240 is preferably  
15 positioned substantially along the centerline of the apparatus 200.

The fluid passage 240 is preferably selected to convey materials such as cement, drilling mud or epoxies at flow rates and pressures ranging from about 0 to 3,000 gallons/minute and 0 to 9,000 psi in order to optimally fill the annular region between the tubular member 210 and the new section 130 of the wellbore 100 with  
20 fluidic materials. The fluid passage 240 includes an inlet geometry that can receive a dart and/or a ball sealing member. In this manner, the fluid passage 240 can be sealed off by introducing a plug, dart and/or ball sealing elements into the fluid passage 230.

The seals 245 are coupled to and supported by an end portion 260 of the tubular member 210. The seals 245 are further positioned on an outer surface 265 of the end  
25 portion 260 of the tubular member 210. The seals 245 permit the overlapping joint between the end portion 270 of the casing 115 and the portion 260 of the tubular member 210 to be fluidically sealed. The seals 245 may comprise any number of conventional commercially available seals such as, for example, lead, rubber, Teflon, or epoxy seals modified in accordance with the teachings of the present disclosure.  
30 The seals 245 are molded from Stratalock epoxy available from Halliburton Energy Services in Dallas, TX in order to optimally provide a load bearing interference fit

between the end 260 of the tubular member 210 and the end 270 of the existing casing 115.

5 The seals 245 are selected to optimally provide a sufficient frictional force to support the expanded tubular member 210 from the existing casing 115. The frictional force optimally provided by the seals 245 ranges from about 1,000 to 1,000,000 lbf in order to optimally support the expanded tubular member 210.

10 The support member 250 is coupled to the expandable mandrel 205, tubular member 210, shoe 215, and seals 220 and 225. The support member 250 preferably comprises an annular member having sufficient strength to carry the apparatus 200 into the new section 130 of the wellbore 100. The support member 250 further includes one or more conventional centralizers (not illustrated) to help stabilize the apparatus 200.

15 A quantity of lubricant 275 is provided in the annular region above the expandable mandrel 205 within the interior of the tubular member 210. In this manner, the extrusion of the tubular member 210 off of the expandable mandrel 205 is facilitated. The lubricant 275 may comprise any number of conventional commercially available lubricants such as, for example, Lubriplate, chlorine based lubricants, oil based lubricants or Climax 1500 Antisieze (3100). The lubricant 275 comprises Climax 1500 Antisieze (3100) available from Climax Lubricants and  
20 Equipment Co. in Houston, TX in order to optimally provide optimum lubrication to facilitate the expansion process.

25 The support member 250 is thoroughly cleaned prior to assembly to the remaining portions of the apparatus 200. In this manner, the introduction of foreign material into the apparatus 200 is minimized. This minimizes the possibility of foreign material clogging the various flow passages and valves of the apparatus 200.

30 Before or after positioning the apparatus 200 within the new section 130 of the wellbore 100, a couple of wellbore volumes are circulated in order to ensure that no foreign materials are located within the wellbore 100 that might clog up the various flow passages and valves of the apparatus 200 and to ensure that no foreign material interferes with the expansion process.

As illustrated in Fig. 3, the fluid passage 235 is then closed and a hardenable fluidic sealing material 305 is then pumped from a surface location into the fluid

passage 230. The material 305 then passes from the fluid passage 230 into the interior region 310 of the tubular member 210 below the expandable mandrel 205. The material 305 then passes from the interior region 310 into the fluid passage 240. The material 305 then exits the apparatus 200 and fills the annular region 315 between the exterior of the tubular member 210 and the interior wall of the new section 130 of the wellbore 100. Continued pumping of the material 305 causes the material 305 to fill up at least a portion of the annular region 315.

The material 305 is preferably pumped into the annular region 315 at pressures and flow rates ranging, for example, from about 0 to 5000 psi and 0 to 1,500 gallons/min, respectively. The optimum flow rate and operating pressures vary as a function of the casing and wellbore sizes, wellbore section length, available pumping equipment, and fluid properties of the fluidic material being pumped. The optimum flow rate and operating pressure are preferably determined using conventional empirical methods.

The hardenable fluidic sealing material 305 may comprise any number of conventional commercially available hardenable fluidic sealing materials such as, for example, slag mix, cement or epoxy. The hardenable fluidic sealing material 305 comprises a blended cement prepared specifically for the particular well section being drilled from Halliburton Energy Services in Dallas, TX in order to provide optimal support for tubular member 210 while also maintaining optimum flow characteristics so as to minimize difficulties during the displacement of cement in the annular region 315. The optimum blend of the blended cement is preferably determined using conventional empirical methods.

The annular region 315 preferably is filled with the material 305 in sufficient quantities to ensure that, upon radial expansion of the tubular member 210, the annular region 315 of the new section 130 of the wellbore 100 will be filled with material 305.

As illustrated in Fig. 3a, the wall thickness and/or the outer diameter of the tubular member 210 is reduced in the region adjacent to the mandrel 205 in order to optimally permit placement of the apparatus 200 in positions in the wellbore with tight clearances. Furthermore, in this manner, the initiation of the radial expansion of the tubular member 210 during the extrusion process is optimally facilitated.

As illustrated in Fig. 4, once the annular region 315 has been adequately filled with material 305, a plug 405, or other similar device, is introduced into the fluid passage 240 thereby fluidically isolating the interior region 310 from the annular region 315. A non-hardenable fluidic material 306 is then pumped into the interior region 310 causing the interior region to pressurize. In this manner, the interior of the expanded tubular member 210 will not contain significant amounts of cured material 305. This reduces and simplifies the cost of the entire process. Alternatively, the material 305 may be used during this phase of the process.

Once the interior region 310 becomes sufficiently pressurized, the tubular member 210 is extruded off of the expandable mandrel 205. During the extrusion process, the expandable mandrel 205 may be raised out of the expanded portion of the tubular member 210. During the extrusion process, the mandrel 205 is raised at approximately the same rate as the tubular member 210 is expanded in order to keep the tubular member 210 stationary relative to the new wellbore section 130. The extrusion process is commenced with the tubular member 210 positioned above the bottom of the new wellbore section 130, keeping the mandrel 205 stationary, and allowing the tubular member 210 to extrude off of the mandrel 205 and fall down the new wellbore section 130 under the force of gravity.

The plug 405 is preferably placed into the fluid passage 240 by introducing the plug 405 into the fluid passage 230 at a surface location in a conventional manner. The plug 405 preferably acts to fluidically isolate the hardenable fluidic sealing material 305 from the non hardenable fluidic material 306.

The plug 405 may comprise any number of conventional commercially available devices from plugging a fluid passage such as, for example, Multiple Stage Cementer (MSC) latch-down plug, Omega latch-down plug or three-wiper latch-down plug modified in accordance with the teachings of the present disclosure. The plug 405 comprises a MSC latch-down plug available from Halliburton Energy Services in Dallas, TX.

After placement of the plug 405 in the fluid passage 240, a non hardenable fluidic material 306 is preferably pumped into the interior region 310 at pressures and flow rates ranging, for example, from approximately 400 to 10,000 psi and 30 to 4,000 gallons/min. In this manner, the amount of hardenable fluidic sealing material within



the interior 310 of the tubular member 210 is minimized. After placement of the plug 405 in the fluid passage 240, the non hardenable material 306 is preferably pumped into the interior region 310 at pressures and flow rates ranging from approximately 500 to 9,000 psi and 40 to 3,000 gallons/min in order to maximize the extrusion speed.

5 The apparatus 200 is adapted to minimize tensile, burst, and friction effects upon the tubular member 210 during the expansion process. These effects will depend upon the geometry of the expansion mandrel 205, the material composition of the tubular member 210 and expansion mandrel 205, the inner diameter of the tubular member 210, the wall thickness of the tubular member 210, the type of lubricant, and  
10 the yield strength of the tubular member 210. In general, the thicker the wall thickness, the smaller the inner diameter, and the greater the yield strength of the tubular member 210, then the greater the operating pressures required to extrude the tubular member 210 off of the mandrel 205.

For typical tubular members 210, the extrusion of the tubular member 210 off  
15 of the expandable mandrel will begin when the pressure of the interior region 310 reaches, for example, approximately 500 to 9,000 psi.

During the extrusion process, the expandable mandrel 205 may be raised out of the expanded portion of the tubular member 210 at rates ranging, for example, from about 0 to 5 ft/sec. During the extrusion process, the expandable mandrel 205 is raised  
20 out of the expanded portion of the tubular member 210 at rates ranging from about 0 to 2 ft/sec in order to minimize the time required for the expansion process while also permitting easy control of the expansion process.

When the end portion 260 of the tubular member 210 is extruded off of the expandable mandrel 205, the outer surface 265 of the end portion 260 of the tubular  
25 member 210 will preferably contact the interior surface 410 of the end portion 270 of the casing 115 to form an fluid tight overlapping joint. The contact pressure of the overlapping joint may range, for example, from approximately 50 to 20,000 psi. The contact pressure of the overlapping joint ranges from approximately 400 to 10,000 psi in order to provide optimum pressure to activate the annular sealing members 245 and  
30 optimally provide resistance to axial motion to accommodate typical tensile and compressive loads.

The overlapping joint between the section 410 of the existing casing 115 and the section 265 of the expanded tubular member 210 preferably provides a gaseous and fluidic seal. The sealing members 245 optimally provide a fluidic and gaseous seal in the overlapping joint.

5 The operating pressure and flow rate of the non hardenable fluidic material 306 is controllably ramped down when the expandable mandrel 205 reaches the end portion 260 of the tubular member 210. In this manner, the sudden release of pressure caused by the complete extrusion of the tubular member 210 off of the expandable mandrel 205 can be minimized. The operating pressure is reduced in a substantially  
10 linear fashion from 100% to about 10% during the end of the extrusion process beginning when the mandrel 205 is within about 5 feet from completion of the extrusion process.

Alternatively, or in combination, a shock absorber is provided in the support member 250 in order to absorb the shock caused by the sudden release of pressure.  
15 The shock absorber may comprise, for example, any conventional commercially available shock absorber adapted for use in wellbore operations.

Alternatively, or in combination, a mandrel catching structure is provided in the end portion 260 of the tubular member 210 in order to catch or at least decelerate the mandrel 205.

20 Once the extrusion process is completed, the expandable mandrel 205 is removed from the wellbore 100. Either before or after the removal of the expandable mandrel 205, the integrity of the fluidic seal of the overlapping joint between the upper portion 260 of the tubular member 210 and the lower portion 270 of the casing 115 is tested using conventional methods.

25 If the fluidic seal of the overlapping joint between the upper portion 260 of the tubular member 210 and the lower portion 270 of the casing 115 is satisfactory, then any uncured portion of the material 305 within the expanded tubular member 210 is then removed in a conventional manner such as, for example, circulating the uncured material out of the interior of the expanded tubular member 210. The mandrel 205 is  
30 then pulled out of the wellbore section 130 and a drill bit or mill is used in combination with a conventional drilling assembly 505 to drill out any hardened material 305 within

the tubular member 210. The material 305 within the annular region 315 is then allowed to cure.

As illustrated in Fig. 5, preferably any remaining cured material 305 within the interior of the expanded tubular member 210 is then removed in a conventional manner using a conventional drill string 505. The resulting new section of casing 510 includes the expanded tubular member 210 and an outer annular layer 515 of cured material 305. The bottom portion of the apparatus 200 comprising the shoe 215 and dart 405 may then be removed by drilling out the shoe 215 and dart 405 using conventional drilling methods.

As illustrated in Fig. 6, the upper portion 260 of the tubular member 210 includes one or more sealing members 605 and one or more pressure relief holes 610. In this manner, the overlapping joint between the lower portion 270 of the casing 115 and the upper portion 260 of the tubular member 210 is pressure-tight and the pressure on the interior and exterior surfaces of the tubular member 210 is equalized during the extrusion process.

The sealing members 605 are seated within recesses 615 formed in the outer surface 265 of the upper portion 260 of the tubular member 210. The sealing members 605 are bonded or molded onto the outer surface 265 of the upper portion 260 of the tubular member 210. The pressure relief holes 610 are preferably positioned in the last few feet of the tubular member 210. The pressure relief holes reduce the operating pressures required to expand the upper portion 260 of the tubular member 210. This reduction in required operating pressure in turn reduces the velocity of the mandrel 205 upon the completion of the extrusion process. This reduction in velocity in turn minimizes the mechanical shock to the entire apparatus 200 upon the completion of the extrusion process.

Referring now to Fig. 7, an apparatus 700 for forming a casing within a wellbore preferably includes an expandable mandrel or pig 705, an expandable mandrel or pig container 710, a tubular member 715, a float shoe 720, a lower cup seal 725, an upper cup seal 730, a fluid passage 735, a fluid passage 740, a support member 745, a body of lubricant 750, an overshot connection 755, another support member 760, and a stabilizer 765.

The expandable mandrel 705 is coupled to and supported by the support member 745. The expandable mandrel 705 is further coupled to the expandable mandrel container 710. The expandable mandrel 705 is preferably adapted to controllably expand in a radial direction. The expandable mandrel 705 may comprise  
5 any number of conventional commercially available expandable mandrels modified in accordance with the teachings of the present disclosure. The expandable mandrel 705 comprises a hydraulic expansion tool substantially as disclosed in U.S. Pat. No. 5,348,095, the contents of which are incorporated herein by reference, modified in accordance with the teachings of the present disclosure.

10 The expandable mandrel container 710 is coupled to and supported by the support member 745. The expandable mandrel container 710 is further coupled to the expandable mandrel 705. The expandable mandrel container 710 may be constructed from any number of conventional commercially available materials such as, for example, Oilfield Country Tubular Goods, stainless steel, titanium or high strength  
15 steels. The expandable mandrel container 710 is fabricated from material having a greater strength than the material from which the tubular member 715 is fabricated. In this manner, the container 710 can be fabricated from a tubular material having a thinner wall thickness than the tubular member 210. This permits the container 710 to pass through tight clearances thereby facilitating its placement within the wellbore.

20 Once the expansion process begins, and the thicker, lower strength material of the tubular member 715 is expanded, the outside diameter of the tubular member 715 is greater than the outside diameter of the container 710.

The tubular member 715 is coupled to and supported by the expandable mandrel 705. The tubular member 715 is preferably expanded in the radial direction  
25 and extruded off of the expandable mandrel 705 substantially as described above with reference to Figs. 1-6. The tubular member 715 may be fabricated from any number of materials such as, for example, Oilfield Country Tubular Goods (OCTG), automotive grade steel or plastics. The tubular member 715 is fabricated from OCTG.

30 The tubular member 715 has a substantially annular cross-section. The tubular member 715 has a substantially circular annular cross-section.

The tubular member 715 preferably includes an upper section 805, an intermediate section 810, and a lower section 815. The upper section 805 of the

tubular member 715 preferably is defined by the region beginning in the vicinity of the mandrel container 710 and ending with the top section 820 of the tubular member 715.

The intermediate section 810 of the tubular member 715 is preferably defined by the region beginning in the vicinity of the top of the mandrel container 710 and ending  
5 with the region in the vicinity of the mandrel 705. The lower section 815 of the tubular member 715 is preferably defined by the region beginning in the vicinity of the mandrel 705 and ending at the bottom 825 of the tubular member 715.

The wall thickness of the upper section 805 of the tubular member 715 is  
10 greater than the wall thicknesses of the intermediate and lower sections 810 and 815 of the tubular member 715 in order to optimally facilitate the initiation of the extrusion process and optimally permit the apparatus 700 to be positioned in locations in the wellbore having tight clearances.

The outer diameter and wall thickness of the upper section 805 of the tubular  
15 member 715 may range, for example, from about 1.05 to 48 inches and 1/8 to 2 inches, respectively. The outer diameter and wall thickness of the upper section 805 of the tubular member 715 range from about 3.5 to 16 inches and 3/8 to 1.5 inches, respectively.

The outer diameter and wall thickness of the intermediate section 810 of the  
20 tubular member 715 may range, for example, from about 2.5 to 50 inches and 1/16 to 1.5 inches, respectively. The outer diameter and wall thickness of the intermediate section 810 of the tubular member 715 range from about 3.5 to 19 inches and 1/8 to 1.25 inches, respectively.

The outer diameter and wall thickness of the lower section 815 of the tubular  
25 member 715 may range, for example, from about 2.5 to 50 inches and 1/16 to 1.25 inches, respectively. The outer diameter and wall thickness of the lower section 810 of the tubular member 715 range from about 3.5 to 19 inches and 1/8 to 1.25 inches, respectively. The wall thickness of the lower section 815 of the tubular member 715 is further increased to increase the strength of the shoe 720 when drillable materials such as, for example, aluminum are used.

30 The tubular member 715 preferably comprises a solid tubular member. The end portion 820 of the tubular member 715 is slotted, perforated, or otherwise modified to catch or slow down the mandrel 705 when it completes the extrusion of tubular

member 715. The length of the tubular member 715 is limited to minimize the possibility of buckling. For typical tubular member 715 materials, the length of the tubular member 715 is preferably limited to between about 40 to 20,000 feet in length.

The shoe 720 is coupled to the expandable mandrel 705 and the tubular member 715. The shoe 720 includes the fluid passage 740. The shoe 720 further includes an inlet passage 830, and one or more jet ports 835. The cross-sectional shape of the inlet passage 830 is adapted to receive a latch-down dart, or other similar elements, for blocking the inlet passage 830. The interior of the shoe 720 preferably includes a body of solid material 840 for increasing the strength of the shoe 720. The body of solid material 840 comprises aluminum.

The shoe 720 may comprise any number of conventional commercially available shoes such as, for example, Super Seal II Down-Jet float shoe, or guide shoe with a sealing sleeve for a latch down plug modified in accordance with the teachings of the present disclosure. The shoe 720 comprises an aluminum down-jet guide shoe with a sealing sleeve for a latch-down plug available from Halliburton Energy Services in Dallas, TX, modified in accordance with the teachings of the present disclosure, in order to optimize guiding the tubular member 715 in the wellbore, optimize the seal between the tubular member 715 and an existing wellbore casing, and to optimally facilitate the removal of the shoe 720 by drilling it out after completion of the extrusion process.

The lower cup seal 725 is coupled to and supported by the support member 745. The lower cup seal 725 prevents foreign materials from entering the interior region of the tubular member 715 above the expandable mandrel 705. The lower cup seal 725 may comprise any number of conventional commercially available cup seals such as, for example, TP cups or Selective Injection Packer (SIP) cups modified in accordance with the teachings of the present disclosure. The lower cup seal 725 comprises a SIP cup, available from Halliburton Energy Services in Dallas, TX in order to optimally provide a debris barrier and hold a body of lubricant.

The upper cup seal 730 is coupled to and supported by the support member 760. The upper cup seal 730 prevents foreign materials from entering the interior region of the tubular member 715. The upper cup seal 730 may comprise any number of conventional commercially available cup seals such as, for example, TP cups or

Selective Injection Packer (SIP) cup modified in accordance with the teachings of the present disclosure. The upper cup seal 730 comprises a SIP cup available from Halliburton Energy Services in Dallas, TX in order to optimally provide a debris barrier and contain a body of lubricant.

5 The fluid passage 735 permits fluidic materials to be transported to and from the interior region of the tubular member 715 below the expandable mandrel 705. The fluid passage 735 is fluidically coupled to the fluid passage 740. The fluid passage 735 is preferably coupled to and positioned within the support member 760, the support member 745, the mandrel container 710, and the expandable mandrel 705. The fluid  
10 passage 735 preferably extends from a position adjacent to the surface to the bottom of the expandable mandrel 705. The fluid passage 735 is preferably positioned along a centerline of the apparatus 700. The fluid passage 735 is preferably selected to transport materials such as cement, drilling mud or epoxies at flow rates and pressures ranging from about 40 to 3,000 gallons/minute and 500 to 9,000 psi in order to  
15 optimally provide sufficient operating pressures to extrude the tubular member 715 off of the expandable mandrel 705.

As described above with reference to Figs. 1-6, during placement of the apparatus 700 within a new section of a wellbore, fluidic materials forced up the fluid passage 735 can be released into the wellbore above the tubular member 715. The  
20 apparatus 700 further includes a pressure release passage that is coupled to and positioned within the support member 260. The pressure release passage is further fluidically coupled to the fluid passage 735. The pressure release passage preferably includes a control valve for controllably opening and closing the fluid passage. The control valve is pressure activated in order to controllably minimize surge pressures.  
25 The pressure release passage is preferably positioned substantially orthogonal to the centerline of the apparatus 700. The pressure release passage is preferably selected to convey materials such as cement, drilling mud or epoxies at flow rates and pressures ranging from about 0 to 500 gallons/minute and 0 to 1,000 psi in order to reduce the drag on the apparatus 700 during insertion into a new section of a wellbore and to  
30 minimize surge pressures on the new wellbore section.

The fluid passage 740 permits fluidic materials to be transported to and from the region exterior to the tubular member 715. The fluid passage 740 is preferably

coupled to and positioned within the shoe 720 in fluidic communication with the interior region of the tubular member 715 below the expandable mandrel 705. The fluid passage 740 preferably has a cross-sectional shape that permits a plug, or other similar device, to be placed in the inlet 830 of the fluid passage 740 to thereby block further passage of fluidic materials. In this manner, the interior region of the tubular member 715 below the expandable mandrel 705 can be optimally fluidically isolated from the region exterior to the tubular member 715. This permits the interior region of the tubular member 715 below the expandable mandrel 205 to be pressurized.

The fluid passage 740 is preferably positioned substantially along the centerline of the apparatus 700. The fluid passage 740 is preferably selected to convey materials such as cement, drilling mud or epoxies at flow rates and pressures ranging from about 0 to 3,000 gallons/minute and 0 to 9,000 psi in order to optimally fill an annular region between the tubular member 715 and a new section of a wellbore with fluidic materials. The fluid passage 740 includes an inlet passage 830 having a geometry that can receive a dart and/or a ball sealing member. In this manner, the fluid passage 740 can be sealed off by introducing a plug, dart and/or ball sealing elements into the inlet 830.

The apparatus 700 further includes one or more seals 845 coupled to and supported by the end portion 820 of the tubular member 715. The seals 845 are further positioned on an outer surface of the end portion 820 of the tubular member 715. The seals 845 permit the overlapping joint between an end portion of preexisting casing and the end portion 820 of the tubular member 715 to be fluidically sealed. The seals 845 may comprise any number of conventional commercially available seals such as, for example, lead, rubber, Teflon, or epoxy seals modified in accordance with the teachings of the present disclosure. The seals 845 comprise seals molded from StrataLock epoxy available from Halliburton Energy Services in Dallas, TX in order to optimally provide a hydraulic seal and a load bearing interference fit in the overlapping joint between the tubular member 715 and an existing casing with optimal load bearing capacity to support the tubular member 715.

The seals 845 are selected to provide a sufficient frictional force to support the expanded tubular member 715 from the existing casing. The frictional force provided



fluidic seal. The tubular liner 810 is formed within a horizontally positioned pipeline section, such as those used to transport hydrocarbons or water, with the tubular liner 810 placed in an overlapping relationship with the adjacent pipeline section. In this manner, underground pipelines can be repaired without having to dig out and replace the damaged sections.

The method and apparatus described herein is used to directly line a wellbore with a tubular liner 810. An outer annular lining of cement is not provided between the tubular liner 810 and the wellbore. Any number of fluidic materials can be used to expand the tubular liner 810 into intimate contact with the wellbore such as, for example, cement, epoxy, slag mix, or drilling mud.

Referring now to Figs. 9, 9a, 9b and 9c, an apparatus 900 for forming a wellbore casing includes an expandible tubular member 902, a support member 904, an expandible mandrel or pig 906, and a shoe 908. The design and construction of the mandrel 906 and shoe 908 permits easy removal of those elements by drilling them out. In this manner, the assembly 900 can be easily removed from a wellbore using a conventional drilling apparatus and corresponding drilling methods.

The expandible tubular member 902 preferably includes an upper portion 910, an intermediate portion 912 and a lower portion 914. During operation of the apparatus 900, the tubular member 902 is preferably extruded off of the mandrel 906 by pressurizing an interior region 966 of the tubular member 902. The tubular member 902 preferably has a substantially annular cross-section.

An expandable tubular member 915 is coupled to the upper portion 910 of the expandable tubular member 902. During operation of the apparatus 900, the tubular member 915 is preferably extruded off of the mandrel 906 by pressurizing the interior region 966 of the tubular member 902. The tubular member 915 preferably has a substantially annular cross-section. The wall thickness of the tubular member 915 is greater than the wall thickness of the tubular member 902.

The tubular member 915 may be fabricated from any number of conventional commercially available materials such as, for example, oilfield tubulars, low alloy steels, titanium or stainless steels. The tubular member 915 is fabricated from oilfield tubulars in order to optimally provide approximately the same mechanical properties as the tubular member 902. The tubular member 915 has a plastic yield point ranging

from about 40,000 to 135,000 psi in order to optimally provide approximately the same yield properties as the tubular member 902. The tubular member 915 may comprise a plurality of tubular members coupled end to end.

5 The upper end portion of the tubular member 915 includes one or more sealing members for optimally providing a fluidic and/or gaseous seal with an existing section of wellbore casing.

The combined length of the tubular members 902 and 915 are limited to minimize the possibility of buckling. For typical tubular member materials, the combined length of the tubular members 902 and 915 are limited to between about 40  
10 to 20,000 feet in length.

The lower portion 914 of the tubular member 902 is preferably coupled to the shoe 908 by a threaded connection 968. The intermediate portion 912 of the tubular member 902 preferably is placed in intimate sliding contact with the mandrel 906.

The tubular member 902 may be fabricated from any number of conventional  
15 commercially available materials such as, for example, oilfield tubulars, low alloy steels, titanium or stainless steels. The tubular member 902 is fabricated from oilfield tubulars in order to optimally provide approximately the same mechanical properties as the tubular member 915. The tubular member 902 has a plastic yield point ranging from about 40,000 to 135,000 psi in order to optimally provide approximately the same  
20 yield properties as the tubular member 915.

The wall thickness of the upper, intermediate, and lower portions, 910, 912 and 914 of the tubular member 902 may range, for example, from about 1/16 to 1.5 inches. The wall thickness of the upper, intermediate, and lower portions, 910, 912 and 914 of the tubular member 902 range from about 1/8 to 1.25 in order to optimally provide  
25 wall thickness that are about the same as the tubular member 915. The wall thickness of the lower portion 914 is less than or equal to the wall thickness of the upper portion 910 in order to optimally provide a geometry that will fit into tight clearances downhole.

The outer diameter of the upper, intermediate, and lower portions, 910, 912 and  
30 914 of the tubular member 902 may range, for example, from about 1.05 to 48 inches. The outer diameter of the upper, intermediate, and lower portions, 910, 912 and 914 of

the tubular member 902 range from about 3 2 to 19 inches in order to optimally provide the ability to expand the most commonly used oilfield tubulars.

5 The length of the tubular member 902 is preferably limited to between about 2 to 5 feet in order to optimally provide enough length to contain the mandrel 906 and a body of lubricant.

The tubular member 902 may comprise any number of conventional commercially available tubular members modified in accordance with the teachings of the present disclosure. The tubular member 902 comprises Oilfield Country Tubular Goods available from various U.S. steel mills. The tubular member 915 may comprise  
10 any number of conventional commercially available tubular members modified in accordance with the teachings of the present disclosure. The tubular member 915 comprises Oilfield Country Tubular Goods available from various U.S. steel mills.

The various elements of the tubular member 902 may be coupled using any number of conventional process such as, for example, threaded connections, welding  
15 or machined from one piece. The various elements of the tubular member 902 are coupled using welding. The tubular member 902 may comprise a plurality of tubular elements that are coupled end to end. The various elements of the tubular member 915 may be coupled using any number of conventional process such as, for example, threaded connections, welding or machined from one piece. The various elements of  
20 the tubular member 915 are coupled using welding. The tubular member 915 may comprise a plurality of tubular elements that are coupled end to end. The tubular members 902 and 915 may be coupled using any number of conventional process such as, for example, threaded connections, welding or machined from one piece.

The support member 904 preferably includes an innerstring adapter 916, a fluid  
25 passage 918, an upper guide 920, and a coupling 922. During operation of the apparatus 900, the support member 904 preferably supports the apparatus 900 during movement of the apparatus 900 within a wellbore. The support member 904 preferably has a substantially annular cross-section.

The support member 904 may be fabricated from any number of conventional  
30 commercially available materials such as, for example, oilfield tubulars, low alloy steel, coiled tubing or stainless steel. The support member 904 is fabricated from low alloy steel in order to optimally provide high yield strength.

The innerstring adaptor 916 preferably is coupled to and supported by a conventional drill string support from a surface location. The innerstring adaptor 916 may be coupled to a conventional drill string support 971 by a threaded connection 970.

5 The fluid passage 918 is preferably used to convey fluids and other materials to and from the apparatus 900. The fluid passage 918 is fluidically coupled to the fluid passage 952. The fluid passage 918 is used to convey hardenable fluidic sealing materials to and from the apparatus 900. The fluid passage 918 may include one or more pressure relief passages (not illustrated) to release fluid pressure during  
10 positioning of the apparatus 900 within a wellbore. The fluid passage 918 is positioned along a longitudinal centerline of the apparatus 900. The fluid passage 918 is selected to permit the conveyance of hardenable fluidic materials at operating pressures ranging from about 0 to 9,000 psi.

The upper guide 920 is coupled to an upper portion of the support member 904.  
15 The upper guide 920 preferably is adapted to center the support member 904 within the tubular member 915. The upper guide 920 may comprise any number of conventional guide members modified in accordance with the teachings of the present disclosure. The upper guide 920 comprises an innerstring adapter available from Halliburton Energy Services in Dallas, TX order to optimally guide the apparatus 900  
20 within the tubular member 915.

The coupling 922 couples the support member 904 to the mandrel 906. The coupling 922 preferably comprises a conventional threaded connection.

The various elements of the support member 904 may be coupled using any number of conventional processes such as, for example, welding, threaded connections  
25 or machined from one piece. The various elements of the support member 904 are coupled using threaded connections.

The mandrel 906 preferably includes a retainer 924, a rubber cup 926, an expansion cone 928, a lower cone retainer 930, a body of cement 932, a lower guide 934, an extension sleeve 936, a spacer 938, a housing 940, a scaling sleeve 942, an  
30 upper cone retainer 944, a lubricator mandrel 946, a lubricator sleeve 948, a guide 950, and a fluid passage 952.

The retainer 924 is coupled to the lubricator mandrel 946, lubricator sleeve 948, and the rubber cup 926. The retainer 924 couples the rubber cup 926 to the lubricator sleeve 948. The retainer 924 preferably has a substantially annular cross-section. The retainer 924 may comprise any number of conventional commercially available retainers such as, for example, slotted spring pins or roll pin.

The rubber cup 926 is coupled to the retainer 924, the lubricator mandrel 946, and the lubricator sleeve 948. The rubber cup 926 prevents the entry of foreign materials into the interior region 972 of the tubular member 902 below the rubber cup 926. The rubber cup 926 may comprise any number of conventional commercially available rubber cups such as, for example, TP cups or Selective Injection Packer (SIP) cup. The rubber cup 926 comprises a SIP cup available from Halliburton Energy Services in Dallas, TX in order to optimally block foreign materials.

A body of lubricant is further provided in the interior region 972 of the tubular member 902 in order to lubricate the interface between the exterior surface of the mandrel 902 and the interior surface of the tubular members 902 and 915. The lubricant may comprise any number of conventional commercially available lubricants such as, for example, Lubriplate, chlorine based lubricants, oil based lubricants or Climax 1500 Antiseize (3100). The lubricant comprises Climax 1500 Antiseize (3100) available from Climax Lubricants and Equipment Co. in Houston, TX in order to optimally provide lubrication to facilitate the extrusion process.

The expansion cone 928 is coupled to the lower cone retainer 930, the body of cement 932, the lower guide 934, the extension sleeve 936, the housing 940, and the upper cone retainer 944. During operation of the apparatus 900, the tubular members 902 and 915 are extruded off of the outer surface of the expansion cone 928. Axial movement of the expansion cone 928 is prevented by the lower cone retainer 930, housing 940 and the upper cone retainer 944. Inner radial movement of the expansion cone 928 is prevented by the body of cement 932, the housing 940, and the upper cone retainer 944.

The expansion cone 928 preferably has a substantially annular cross section. The outside diameter of the expansion cone 928 is preferably tapered to provide a cone shape. The wall thickness of the expansion cone 928 may range, for example, from about 0.125 to 3 inches. The wall thickness of the expansion cone 928 ranges from

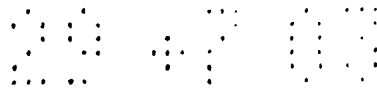

about 0.25 to 0.75 inches in order to optimally provide adequate compressive strength with minimal material. The maximum and minimum outside diameters of the expansion cone 928 may range, for example, from about 1 to 47 inches. The maximum and minimum outside diameters of the expansion cone 928 range from about 3.5 to 19 in order to optimally provide expansion of generally available oilfield tubulars

The expansion cone 928 may be fabricated from any number of conventional commercially available materials such as, for example, ceramic, tool steel, titanium or low alloy steel. The expansion cone 928 is fabricated from tool steel in order to optimally provide high strength and abrasion resistance. The surface hardness of the outer surface of the expansion cone 928 may range, for example, from about 50 Rockwell C to 70 Rockwell C. The surface hardness of the outer surface of the expansion cone 928 ranges from about 58 Rockwell C to 62 Rockwell C in order to optimally provide high yield strength. The expansion cone 928 is heat treated to optimally provide a hard outer surface and a resilient interior body in order to optimally provide abrasion resistance and fracture toughness.

The lower cone retainer 930 is coupled to the expansion cone 928 and the housing 940. Axial movement of the expansion cone 928 is prevented by the lower cone retainer 930. Preferably, the lower cone retainer 930 has a substantially annular cross-section.

The lower cone retainer 930 may be fabricated from any number of conventional commercially available materials such as, for example, ceramic, tool steel, titanium or low alloy steel. The lower cone retainer 930 is fabricated from tool steel in order to optimally provide high strength and abrasion resistance. The surface hardness of the outer surface of the lower cone retainer 930 may range, for example, from about 50 Rockwell C to 70 Rockwell C. The surface hardness of the outer surface of the lower cone retainer 930 ranges from about 58 Rockwell C to 62 Rockwell C in order to optimally provide high yield strength. The lower cone retainer 930 is heat treated to optimally provide a hard outer surface and a resilient interior body in order to optimally provide abrasion resistance and fracture toughness.

The lower cone retainer 930 and the expansion cone 928 are formed as an integral one-piece element in order to reduce the number of components and increase the

overall strength of the apparatus. The outer surface of the lower cone retainer 930 preferably mates with the inner surfaces of the tubular members 902 and 915.

The body of cement 932 is positioned within the interior of the mandrel 906. The body of cement 932 provides an inner bearing structure for the mandrel 906. The  
5 body of cement 932 further may be easily drilled out using a conventional drill device. In this manner, the mandrel 906 may be easily removed using a conventional drilling device.

The body of cement 932 may comprise any number of conventional commercially available cement compounds. Alternatively, aluminum, cast iron or  
10 some other drillable metallic, composite, or aggregate material may be substituted for cement. The body of cement 932 preferably has a substantially annular cross-section.

The lower guide 934 is coupled to the extension sleeve 936 and housing 940. During operation of the apparatus 900, the lower guide 934 preferably helps guide the movement of the mandrel 906 within the tubular member 902. The lower guide 934  
15 preferably has a substantially annular cross-section.

The lower guide 934 may be fabricated from any number of conventional commercially available materials such as, for example, oilfield tubulars, low alloy steel or stainless steel. The lower guide 934 is fabricated from low alloy steel in order to optimally provide high yield strength. The outer surface of the lower guide 934  
20 preferably mates with the inner surface of the tubular member 902 to provide a sliding fit.

The extension sleeve 936 is coupled to the lower guide 934 and the housing 940. During operation of the apparatus 900, the extension sleeve 936 preferably helps guide the movement of the mandrel 906 within the tubular member 902. The  
25 extension sleeve 936 preferably has a substantially annular cross-section.

The extension sleeve 936 may be fabricated from any number of conventional commercially available materials such as, for example, oilfield tubulars, low alloy steel or stainless steel. The extension sleeve 936 is fabricated from low alloy steel in order to optimally provide high yield strength. The outer surface of the extension sleeve 936  
30 preferably mates with the inner surface of the tubular member 902 to provide a sliding fit. The extension sleeve 936 and the lower guide 934 are formed as an integral one-



piece element in order to minimize the number of components and increase the strength of the apparatus.

5 The spacer 938 is coupled to the sealing sleeve 942. The spacer 938 preferably includes the fluid passage 952 and is adapted to mate with the extension tube 960 of the shoe 908. In this manner, a plug or dart can be conveyed from the surface through the fluid passages 918 and 952 into the fluid passage 962. Preferably, the spacer 938 has a substantially annular cross-section.

10 The spacer 938 may be fabricated from any number of conventional commercially available materials such as, for example, steel, aluminum or cast iron. The spacer 938 is fabricated from aluminum in order to optimally provide drillability. The end of the spacer 938 preferably mates with the end of the extension tube 960. The spacer 938 and the sealing sleeve 942 are formed as an integral one-piece element in order to reduce the number of components and increase the strength of the apparatus.

15 The housing 940 is coupled to the lower guide 934, extension sleeve 936, expansion cone 928, body of cement 932, and lower cone retainer 930. During operation of the apparatus 900, the housing 940 preferably prevents inner radial motion of the expansion cone 928. Preferably, the housing 940 has a substantially annular cross-section.

20 The housing 940 may be fabricated from any number of conventional commercially available materials such as, for example, oilfield tubulars, low alloy steel or stainless steel. The housing 940 is fabricated from low alloy steel in order to optimally provide high yield strength. The lower guide 934, extension sleeve 936 and housing 940 are formed as an integral one-piece element in order to minimize the number of components and increase the strength of the apparatus.

25 The interior surface of the housing 940 includes one or more protrusions to facilitate the connection between the housing 940 and the body of cement 932.

30 The sealing sleeve 942 is coupled to the support member 904, the body of cement 932, the spacer 938, and the upper cone retainer 944. During operation of the apparatus, the sealing sleeve 942 preferably provides support for the mandrel 906. The sealing sleeve 942 is preferably coupled to the support member 904 using the coupling 922. Preferably, the sealing sleeve 942 has a substantially annular cross-section.



The sealing sleeve 942 may be fabricated from any number of conventional commercially available materials such as, for example, steel, aluminum or cast iron. The sealing sleeve 942 is fabricated from aluminum in order to optimally provide drillability of the sealing sleeve 942.

5 The outer surface of the sealing sleeve 942 includes one or more protrusions to facilitate the connection between the sealing sleeve 942 and the body of cement 932.

The spacer 938 and the sealing sleeve 942 are integrally formed as a one-piece element in order to minimize the number of components.

The upper cone retainer 944 is coupled to the expansion cone 928, the sealing sleeve 942, and the body of cement 932. During operation of the apparatus 900, the upper cone retainer 944 preferably prevents axial motion of the expansion cone 928. Preferably, the upper cone retainer 944 has a substantially annular cross-section.

10 The upper cone retainer 944 may be fabricated from any number of conventional commercially available materials such as, for example, steel, aluminum or cast iron. The upper cone retainer 944 is fabricated from aluminum in order to optimally provide drillability of the upper cone retainer 944.

15 The upper cone retainer 944 has a cross-sectional shape designed to provide increased rigidity. The upper cone retainer 944 has a cross-sectional shape that is substantially I-shaped to provide increased rigidity and minimize the amount of material that would have to be drilled out.

20 The lubricator mandrel 946 is coupled to the retainer 924, the rubber cup 926, the upper cone retainer 944, the lubricator sleeve 948, and the guide 950. During operation of the apparatus 900, the lubricator mandrel 946 preferably contains the body of lubricant in the annular region 972 for lubricating the interface between the mandrel 906 and the tubular member 902. Preferably, the lubricator mandrel 946 has a substantially annular cross-section.

The lubricator mandrel 946 may be fabricated from any number of conventional commercially available materials such as, for example, steel, aluminum or cast iron. The lubricator mandrel 946 is fabricated from aluminum in order to optimally provide drillability of the lubricator mandrel 946.

30 The lubricator sleeve 948 is coupled to the lubricator mandrel 946, the retainer 924, the rubber cup 926, the upper cone retainer 944, the lubricator sleeve 948, and the

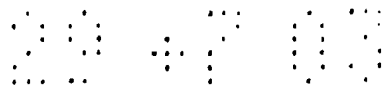

guide 950. During operation of the apparatus 900, the lubricator sleeve 948 preferably supports the rubber cup 926. Preferably, the lubricator sleeve 948 has a substantially annular cross-section.

5 The lubricator sleeve 948 may be fabricated from any number of conventional commercially available materials such as, for example, steel, aluminum or cast iron. The lubricator sleeve 948 is fabricated from aluminum in order to optimally provide drillability of the lubricator sleeve 948.

10 As illustrated in Fig. 9c, the lubricator sleeve 948 is supported by the lubricator mandrel 946. The lubricator sleeve 948 in turn supports the rubber cup 926. The retainer 924 couples the rubber cup 926 to the lubricator sleeve 948. Seals 949a and 949b are provided between the lubricator mandrel 946, lubricator sleeve 948, and rubber cup 926 in order to optimally seal off the interior region 972 of the tubular member 902.

15 The guide 950 is coupled to the lubricator mandrel 946, the retainer 924, and the lubricator sleeve 948. During operation of the apparatus 900, the guide 950 preferably guides the apparatus on the support member 904. Preferably, the guide 950 has a substantially annular cross-section.

20 The guide 950 may be fabricated from any number of conventional commercially available materials such as, for example, steel, aluminum or cast iron. The guide 950 is fabricated from aluminum in order to optimally provide drillability of the guide 950.

25 The fluid passage 952 is coupled to the mandrel 906. During operation of the apparatus, the fluid passage 952 preferably conveys hardenable fluidic materials. The fluid passage 952 is positioned about the centerline of the apparatus 900. The fluid passage 952 is adapted to convey hardenable fluidic materials at pressures and flow rate ranging from about 0 to 9,000 psi and 0 to 3,000 gallons/min in order to optimally provide pressures and flow rates to displace and circulate fluids during the installation of the apparatus 900.

30 The various elements of the mandrel 906 may be coupled using any number of conventional process such as, for example, threaded connections, welded connections or cementing. The various elements of the mandrel 906 are coupled using threaded connections and cementing.

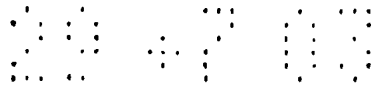

The shoe 908 preferably includes a housing 954, a body of cement 956, a sealing sleeve 958, an extension tube 960, a fluid passage 962, and one or more outlet jets 964.

5 The housing 954 is coupled to the body of cement 956 and the lower portion 914 of the tubular member 902. During operation of the apparatus 900, the housing 954 preferably couples the lower portion of the tubular member 902 to the shoe 908 to facilitate the extrusion and positioning of the tubular member 902. Preferably, the housing 954 has a substantially annular cross-section.

10 The housing 954 may be fabricated from any number of conventional commercially available materials such as, for example, steel or aluminum. The housing 954 is fabricated from aluminum in order to optimally provide drillability of the housing 954.

The interior surface of the housing 954 includes one or more protrusions to facilitate the connection between the body of cement 956 and the housing 954.

15 The body of cement 956 is coupled to the housing 954, and the sealing sleeve 958. The composition of the body of cement 956 is selected to permit the body of cement to be easily drilled out using conventional drilling machines and processes.

The composition of the body of cement 956 may include any number of conventional cement compositions. In an alternative embodiment, a drillable material such as, for example, aluminum or iron may be substituted for the body of cement 956.

20 The scaling sleeve 958 is coupled to the body of cement 956, the extension tube 960, the fluid passage 962, and one or more outlet jets 964. During operation of the apparatus 900, the sealing sleeve 958 preferably is adapted to convey a hardenable fluidic material from the fluid passage 952 into the fluid passage 962 and then into the outlet jets 964 in order to inject the hardenable fluidic material into an annular region external to the tubular member 902. During operation of the apparatus 900, the scaling sleeve 958 further includes an inlet geometry that permits a conventional plug or dart 974 to become lodged in the inlet of the scaling sleeve 958. In this manner, the fluid passage 962 may be blocked thereby fluidically isolating the interior region 966 of the tubular member 902.

30 The sealing sleeve 958 has a substantially annular cross-section. The scaling sleeve 958 may be fabricated from any number of conventional commercially available

materials such as, for example, steel, aluminum or cast iron. The sealing sleeve 958 is fabricated from aluminum in order to optimally provide drillability of the sealing sleeve 958.

5 The extension tube 960 is coupled to the sealing sleeve 958, the fluid passage 962, and one or more outlet jets 964. During operation of the apparatus 900, the extension tube 960 preferably is adapted to convey a hardenable fluidic material from the fluid passage 952 into the fluid passage 962 and then into the outlet jets 964 in order to inject the hardenable fluidic material into an annular region external to the tubular member 902. During operation of the apparatus 900, the extension tube 960  
10 further includes an inlet geometry that permits a conventional plug or dart 974 to become lodged in the inlet of the sealing sleeve 958. In this manner, the fluid passage 962 is blocked thereby fluidically isolating the interior region 966 of the tubular member 902. One end of the extension tube 960 mates with one end of the spacer 938 in order to optimally facilitate the transfer of material between the two.

15 The extension tube 960 has a substantially annular cross-section. The extension tube 960 may be fabricated from any number of conventional commercially available materials such as, for example, steel, aluminum or cast iron. The extension tube 960 is fabricated from aluminum in order to optimally provide drillability of the extension tube 960.

20 The fluid passage 962 is coupled to the sealing sleeve 958, the extension tube 960, and one or more outlet jets 964. During operation of the apparatus 900, the fluid passage 962 is preferably conveys hardenable fluidic materials. The fluid passage 962 is positioned about the centerline of the apparatus 900. The fluid passage 962 is adapted to convey hardenable fluidic materials at pressures and flow rate ranging from  
25 about 0 to 9,000 psi and 0 to 3,000 gallons/min in order to optimally provide fluids at operationally efficient rates.

The outlet jets 964 are coupled to the sealing sleeve 958, the extension tube 960, and the fluid passage 962. During operation of the apparatus 900, the outlet jets 964 preferably convey hardenable fluidic material from the fluid passage 962 to the  
30 region exterior of the apparatus 900. The shoe 908 includes a plurality of outlet jets 964.

The outlet jets 964 comprise passages drilled in the housing 954 and the body of cement 956 in order to simplify the construction of the apparatus 900.

The various elements of the shoe 908 may be coupled using any number of conventional process such as, for example, threaded connections, cement or machined from one piece of material. The various elements of the shoe 908 are coupled using cement.

The assembly 900 is operated substantially as described above with reference to Figs. 1-8 to create a new section of casing in a wellbore or to repair a wellbore casing or pipeline.

In particular, in order to extend a wellbore into a subterranean formation, a drill string is used in a well known manner to drill out material from the subterranean formation to form a new section.

The apparatus 900 for forming a wellbore casing in a subterranean formation is then positioned in the new section of the wellbore. The apparatus 900 includes the tubular member 915. A hardenable fluidic sealing material is then pumped from a surface location into the fluid passage 918. The hardenable fluidic sealing material then passes from the fluid passage 918 into the interior region 966 of the tubular member 902 below the mandrel 906. The hardenable fluidic sealing material then passes from the interior region 966 into the fluid passage 962. The hardenable fluidic sealing material then exits the apparatus 900 via the outlet jets 964 and fills an annular region between the exterior of the tubular member 902 and the interior wall of the new section of the wellbore. Continued pumping of the hardenable fluidic sealing material causes the material to fill up at least a portion of the annular region.

The hardenable fluidic sealing material is preferably pumped into the annular region at pressures and flow rates ranging, for example, from about 0 to 5,000 psi and 0 to 1,500 gallons/min, respectively. The hardenable fluidic sealing material is pumped into the annular region at pressures and flow rates that are designed for the specific wellbore section in order to optimize the displacement of the hardenable fluidic sealing material while not creating high enough circulating pressures such that circulation might be lost and that could cause the wellbore to collapse. The optimum pressures and flow rates are preferably determined using conventional empirical methods.

The hardenable fluidic sealing material may comprise any number of conventional commercially available hardenable fluidic sealing materials such as, for example, slag mix, cement or epoxy. The hardenable fluidic sealing material comprises blended cements designed specifically for the well section being lined available from Halliburton Energy Services in Dallas, TX in order to optimally provide support for the new tubular member while also maintaining optimal flow characteristics so as to minimize operational difficulties during the displacement of the cement in the annular region. The optimum composition of the blended cements is preferably determined using conventional empirical methods.

The annular region preferably is filled with the hardenable fluidic sealing material in sufficient quantities to ensure that, upon radial expansion of the tubular member 902, the annular region of the new section of the wellbore will be filled with hardenable material.

Once the annular region has been adequately filled with hardenable fluidic sealing material, a plug or dart 974, or other similar device, preferably is introduced into the fluid passage 962 thereby fluidically isolating the interior region 966 of the tubular member 902 from the external annular region. A non hardenable fluidic material is then pumped into the interior region 966 causing the interior region 966 to pressurize. The plug or dart 974, or other similar device, preferably is introduced into the fluid passage 962 by introducing the plug or dart 974, or other similar device into the non hardenable fluidic material. In this manner, the amount of cured material within the interior of the tubular members 902 and 915 is minimized.

Once the interior region 966 becomes sufficiently pressurized, the tubular members 902 and 915 are extruded off of the mandrel 906. The mandrel 906 may be fixed or it may be expandible. During the extrusion process, the mandrel 906 is raised out of the expanded portions of the tubular members 902 and 915 using the support member 904. During this extrusion process, the shoe 908 is preferably substantially stationary.

The plug or dart 974 is preferably placed into the fluid passage 962 by introducing the plug or dart 974 into the fluid passage 918 at a surface location in a conventional manner. The plug or dart 974 may comprise any number of conventional commercially available devices for plugging a fluid passage such as, for example,

Multiple Stage Cementer (MSC) latch-down plug, Omega latch-down plug or three-wiper latch down plug modified in accordance with the teachings of the present disclosure. The plug or dart 974 comprises a MSC latch-down plug available from Halliburton Energy Services in Dallas, TX.

5 After placement of the plug or dart 974 in the fluid passage 962, the non hardenable fluidic material is preferably pumped into the interior region 966 at pressures and flow rates ranging from approximately 500 to 9,000 psi and 40 to 3,000 gallons/min in order to optimally extrude the tubular members 902 and 915 off of the mandrel 906.

10 For typical tubular members 902 and 915, the extrusion of the tubular members 902 and 915 off of the expandable mandrel will begin when the pressure of the interior region 966 reaches approximately 500 to 9,000 psi. The extrusion of the tubular members 902 and 915 off of the mandrel 906 begins when the pressure of the interior region 966 reaches approximately 1,200 to 8,500 psi with a flow rate of about 40 to  
15 1250 gallons/minute.

During the extrusion process, the mandrel 906 may be raised out of the expanded portions of the tubular members 902 and 915 at rates ranging, for example, from about 0 to 5 ft/sec. During the extrusion process, the mandrel 906 is raised out of the expanded portions of the tubular members 902 and 915 at rates ranging from about  
20 0 to 2 ft/sec in order to optimally provide pulling speed fast enough to permit efficient operation and permit full expansion of the tubular members 902 and 915 prior to curing of the hardenable fluidic sealing material; but not so fast that timely adjustment of operating parameters during operation is prevented.

When the upper end portion of the tubular member 915 is extruded off of the  
25 mandrel 906, the outer surface of the upper end portion of the tubular member 915 will preferably contact the interior surface of the lower end portion of the existing casing to form an fluid tight overlapping joint. The contact pressure of the overlapping joint may range, for example, from approximately 50 to 20,000 psi. The contact pressure of the overlapping joint between the upper end of the tubular member 915 and the  
30 existing section of wellbore casing ranges from approximately 400 to 10,000 psi in order to optimally provide contact pressure to activate the scaling members and

provide optimal resistance such that the tubular member 915 and existing wellbore casing will carry typical tensile and compressive loads.

The operating pressure and flow rate of the non hardenable fluidic material will be controllably ramped down when the mandrel 906 reaches the upper end portion of the tubular member 915. In this manner, the sudden release of pressure caused by the complete extrusion of the tubular member 915 off of the expandable mandrel 906 can be minimized. The operating pressure is reduced in a substantially linear fashion from 100% to about 10% during the end of the extrusion process beginning when the mandrel 906 has completed approximately all but about the last 5 feet of the extrusion process.

The operating pressure and/or flow rate of the hardenable fluidic sealing material and/or the non hardenable fluidic material are controlled during all phases of the operation of the apparatus 900 to minimize shock.

Alternatively, or in combination, a shock absorber is provided in the support member 904 in order to absorb the shock caused by the sudden release of pressure.

Alternatively, or in combination, a mandrel catching structure is provided above the support member 904 in order to catch or at least decelerate the mandrel 906.

Once the extrusion process is completed, the mandrel 906 is removed from the wellbore. Either before or after the removal of the mandrel 906, the integrity of the fluidic seal of the overlapping joint between the upper portion of the tubular member 915 and the lower portion of the existing casing is tested using conventional methods. If the fluidic seal of the overlapping joint between the upper portion of the tubular member 915 and the lower portion of the existing casing is satisfactory, then the uncured portion of any of the hardenable fluidic sealing material within the expanded tubular member 915 is then removed in a conventional manner. The hardenable fluidic sealing material within the annular region between the expanded tubular member 915 and the existing casing and new section of wellbore is then allowed to cure.

Preferably any remaining cured hardenable fluidic sealing material within the interior of the expanded tubular members 902 and 915 is then removed in a conventional manner using a conventional drill string. The resulting new section of casing preferably includes the expanded tubular members 902 and 915 and an outer annular layer of cured hardenable fluidic sealing material. The bottom portion of the



apparatus 900 comprising the shoe 908 may then be removed by drilling out the shoe 908 using conventional drilling methods.

In an alternative embodiment, during the extrusion process, it may be necessary to remove the entire apparatus 900 from the interior of the wellbore due to a malfunction. In this circumstance, a conventional drill string is used to drill out the interior sections of the apparatus 900 in order to facilitate the removal of the remaining sections. The interior elements of the apparatus 900 are fabricated from materials such as, for example, cement and aluminum, that permit a conventional drill string to be employed to drill out the interior components.

In particular, The composition of the interior sections of the mandrel 906 and shoe 908, including one or more of the body of cement 932, the spacer 938, the scaling sleeve 942, the upper conc retainer 944, the lubricator mandrel 946, the lubricator sleeve 948, the guide 950, the housing 954, the body of cement 956, the scaling sleeve 958, and the extension tube 960, are selected to permit at least some of these components to be drilled out using conventional drilling methods and apparatus. In this manner, in the event of a malfunction downhole, the apparatus 900 may be easily removed from the wellbore.

Referring now to Figs. 10a, 10b, 10c, 10d, 10e, 10f, and 10g a method and apparatus for creating a tie-back liner in a wellbore will now be described. As illustrated in Fig. 10a, a wellbore 1000 positioned in a subterranean formation 1002 includes a first casing 1004 and a second casing 1006.

The first casing 1004 preferably includes a tubular liner 1008 and a cement annulus 1010. The second casing 1006 preferably includes a tubular liner 1012 and a cement annulus 1014. The second casing 1006 is formed by expanding a tubular member substantially as described above with reference to Figs. 1-9c or below with reference to Figs. 11a-11f.

An upper portion of the tubular liner 1012 overlaps with a lower portion of the tubular liner 1008. An outer surface of the upper portion of the tubular liner 1012 includes one or more sealing members 1016 for providing a fluidic seal between the tubular liners 1008 and 1012.

Referring to Fig. 10b, in order to create a tie-back liner that extends from the overlap between the first and second casings, 1004 and 1006, an apparatus 1100 is



preferably provided that includes an expandable mandrel or pig 1105, a tubular member 1110, a shoe 1115, one or more cup seals 1120, a fluid passage 1130, a fluid passage 1135, one or more fluid passages 1140, seals 1145, and a support member 1150.

5           The expandable mandrel or pig 1105 is coupled to and supported by the support member 1150. The expandable mandrel 1105 is preferably adapted to controllably expand in a radial direction. The expandable mandrel 1105 may comprise any number of conventional commercially available expandable mandrels modified in accordance with the teachings of the present disclosure. The expandable mandrel 1105 comprises  
10 a hydraulic expansion tool substantially as disclosed in U.S. Pat. No. 5,348,095, the disclosure of which is incorporated herein by reference, modified in accordance with the teachings of the present disclosure.

          The tubular member 1110 is coupled to and supported by the expandable mandrel 1105. The tubular member 1105 is expanded in the radial direction and  
15 extruded off of the expandable mandrel 1105. The tubular member 1110 may be fabricated from any number of materials such as, for example, Oilfield Country Tubular Goods, 13 chromium tubing or plastic piping. The tubular member 1110 is fabricated from Oilfield Country Tubular Goods.

          The inner and outer diameters of the tubular member 1110 may range, for  
20 example, from approximately 0.75 to 47 inches and 1.05 to 48 inches, respectively. The inner and outer diameters of the tubular member 1110 range from about 3 to 15.5 inches and 3.5 to 16 inches, respectively in order to optimally provide coverage for typical oilfield casing sizes. The tubular member 1110 preferably comprises a solid member.

25           The upper end portion of the tubular member 1110 is slotted, perforated, or otherwise modified to catch or slow down the mandrel 1105 when it completes the extrusion of tubular member 1110. The length of the tubular member 1110 is limited to minimize the possibility of buckling. For typical tubular member 1110 materials, the length of the tubular member 1110 is preferably limited to between about 40 to  
30 20,000 feet in length.

          The shoe 1115 is coupled to the expandable mandrel 1105 and the tubular member 1110. The shoe 1115 includes the fluid passage 1135. The shoe 1115 may

comprise any number of conventional commercially available shoes such as, for example, Super Seal II float shoe, Super Seal II Down-Jet float shoe or a guide shoe with a sealing sleeve for a latch down plug modified in accordance with the teachings of the present disclosure. The shoe 1115 comprises an aluminum down-jet guide shoe with a sealing sleeve for a latch-down plug with side ports radiating off of the exit flow port available from Halliburton Energy Services in Dallas, TX, modified in accordance with the teachings of the present disclosure, in order to optimally guide the tubular member 1100 to the overlap between the tubular member 1100 and the casing 1012, optimally fluidically isolate the interior of the tubular member 1100 after the latch down plug has seated, and optimally permit drilling out of the shoe 1115 after completion of the expansion and cementing operations.

The shoe 1115 includes one or more side outlet ports 1140 in fluidic communication with the fluid passage 1135. In this manner, the shoe 1115 injects hardenable fluidic sealing material into the region outside the shoe 1115 and tubular member 1110. The shoe 1115 includes one or more of the fluid passages 1140 each having an inlet geometry that can receive a dart and/or a ball sealing member. In this manner, the fluid passages 1140 can be sealed off by introducing a plug, dart and/or ball sealing elements into the fluid passage 1130.

The cup seal 1120 is coupled to and supported by the support member 1150. The cup seal 1120 prevents foreign materials from entering the interior region of the tubular member 1110 adjacent to the expandable mandrel 1105. The cup seal 1120 may comprise any number of conventional commercially available cup seals such as, for example, TP cups or Selective Injection Packer (SIP) cups modified in accordance with the teachings of the present disclosure. The cup seal 1120 comprises a SIP cup, available from Halliburton Energy Services in Dallas, TX in order to optimally provide a barrier to debris and contain a body of lubricant.

The fluid passage 1130 permits fluidic materials to be transported to and from the interior region of the tubular member 1110 below the expandable mandrel 1105. The fluid passage 1130 is coupled to and positioned within the support member 1150 and the expandable mandrel 1105. The fluid passage 1130 preferably extends from a position adjacent to the surface to the bottom of the expandable mandrel 1105. The fluid passage 1130 is preferably positioned along a centerline of the apparatus 1100.

The fluid passage 1130 is preferably selected to transport materials such as cement, drilling mud or epoxies at flow rates and pressures ranging from about 0 to 3,000 gallons/minute and 0 to 9,000 psi in order to optimally provide sufficient operating pressures to circulate fluids at operationally efficient rates.

5 The fluid passage 1135 permits fluidic materials to be transmitted from fluid passage 1130 to the interior of the tubular member 1110 below the mandrel 1105.

The fluid passages 1140 permits fluidic materials to be transported to and from the region exterior to the tubular member 1110 and shoe 1115. The fluid passages 1140 are coupled to and positioned within the shoe 1115 in fluidic communication  
10 with the interior region of the tubular member 1110 below the expandable mandrel 1105. The fluid passages 1140 preferably have a cross-sectional shape that permits a plug, or other similar device, to be placed in the fluid passages 1140 to thereby block further passage of fluidic materials. In this manner, the interior region of the tubular member 1110 below the expandable mandrel 1105 can be fluidically isolated from the  
15 region exterior to the tubular member 1105. This permits the interior region of the tubular member 1110 below the expandable mandrel 1105 to be pressurized.

The fluid passages 1140 are preferably positioned along the periphery of the shoe 1115. The fluid passages 1140 are preferably selected to convey materials such as cement, drilling mud or epoxies at flow rates and pressures ranging from about 0 to  
20 3,000 gallons/minute and 0 to 9,000 psi in order to optimally fill the annular region between the tubular member 1110 and the tubular liner 1008 with fluidic materials. The fluid passages 1140 include an inlet geometry that can receive a dart and/or a ball sealing member. In this manner, the fluid passages 1140 can be sealed off by  
25 introducing a plug, dart and/or ball sealing elements into the fluid passage 1130. The apparatus 1100 includes a plurality of fluid passage 1140.

In an alternative embodiment, the base of the shoe 1115 includes a single inlet passage coupled to the fluid passages 1140 that is adapted to receive a plug, or other similar device, to permit the interior region of the tubular member 1110 to be fluidically isolated from the exterior of the tubular member 1110.

30 The seals 1145 are coupled to and supported by a lower end portion of the tubular member 1110. The seals 1145 are further positioned on an outer surface of the lower end portion of the tubular member 1110. The seals 1145 permit the overlapping

joint between the upper end portion of the casing 1012 and the lower end portion of the tubular member 1110 to be fluidically sealed.

The seals 1145 may comprise any number of conventional commercially available seals such as, for example, lead, rubber, Teflon or epoxy seals modified in accordance with the teachings of the present disclosure. The seals 1145 comprise seals 5 molded from Stratalock epoxy available from Halliburton Energy Services in Dallas, TX in order to optimally provide a hydraulic seal in the overlapping joint and optimally provide load carrying capacity to withstand the range of typical tensile and compressive loads.

10 The seals 1145 are selected to optimally provide a sufficient frictional force to support the expanded tubular member 1110 from the tubular liner 1008. The frictional force provided by the seals 1145 ranges from about 1,000 to 1,000,000 lbf in tension and compression in order to optimally support the expanded tubular member 1110.

The support member 1150 is coupled to the expandable mandrel 1105, tubular 15 member 1110, shoe 1115, and seal 1120. The support member 1150 preferably comprises an annular member having sufficient strength to carry the apparatus 1100 into the wellbore 1000. The support member 1150 further includes one or more conventional centralizers (not illustrated) to help stabilize the tubular member 1110.

A quantity of lubricant 1151 is provided in the annular region above the 20 expandable mandrel 1105 within the interior of the tubular member 1110. In this manner, the extrusion of the tubular member 1110 off of the expandable mandrel 1105 is facilitated. The lubricant 1151 may comprise any number of conventional commercially available lubricants such as, for example, Lubriplate, chlorine based lubricants or Climax 1500 Antiseize (3100). The lubricant 1151 comprises Climax 25 1500 Antiseize (3100) available from Climax Lubricants and Equipment Co. in Houston, TX in order to optimally provide lubrication for the extrusion process.

The support member 1150 is thoroughly cleaned prior to assembly to the 30 remaining portions of the apparatus 1100. In this manner, the introduction of foreign material into the apparatus 1100 is minimized. This minimizes the possibility of foreign material clogging the various flow passages and valves of the apparatus 1100 and to ensure that no foreign material interferes with the expansion mandrel 1105 during the extrusion process.

The apparatus 1100 includes a packer 1155 coupled to the bottom section of the shoe 1115 for fluidically isolating the region of the wellbore 1000 below the apparatus 1100. In this manner, fluidic materials are prevented from entering the region of the wellbore 1000 below the apparatus 1100. The packer 1155 may comprise any number of conventional commercially available packers such as, for example, EZ Drill Packer, EZ SV Packer or a drillable cement retainer. The packer 1155 comprises an EZ Drill Packer available from Halliburton Energy Services in Dallas, TX. In an alternative embodiment, a high gel strength pill may be set below the tie-back in place of the packer 1155. In another alternative embodiment, the packer 1155 may be omitted.

Before or after positioning the apparatus 1100 within the wellbore 1100, a couple of wellbore volumes are circulated in order to ensure that no foreign materials are located within the wellbore 1000 that might clog up the various flow passages and valves of the apparatus 1100 and to ensure that no foreign material interferes with the operation of the expansion mandrel 1105.

As illustrated in Fig. 10c, a hardenable fluidic sealing material 1160 is then pumped from a surface location into the fluid passage 1130. The material 1160 then passes from the fluid passage 1130 into the interior region of the tubular member 1110 below the expandable mandrel 1105. The material 1160 then passes from the interior region of the tubular member 1110 into the fluid passages 1140. The material 1160 then exits the apparatus 1100 and fills the annular region between the exterior of the tubular member 1110 and the interior wall of the tubular liner 1008. Continued pumping of the material 1160 causes the material 1160 to fill up at least a portion of the annular region.

The material 1160 may be pumped into the annular region at pressures and flow rates ranging, for example, from about 0 to 5,000 psi and 0 to 1,500 gallons/min, respectively. The material 1160 is pumped into the annular region at pressures and flow rates specifically designed for the casing sizes being run, the annular spaces being filled, the pumping equipment available, and the properties of the fluid being pumped. The optimum flow rates and pressures are preferably calculated using conventional empirical methods.

The hardenable fluidic sealing material 1160 may comprise any number of conventional commercially available hardenable fluidic sealing materials such as, for

example, slag mix, cement or epoxy. The hardenable fluidic sealing material 1160 comprises blended cements specifically designed for well section being tied-back, available from Halliburton Energy Services in Dallas, TX in order to optimally provide proper support for the tubular member 1110 while maintaining optimum flow characteristics so as to minimize operational difficulties during the displacement of cement in the annular region. The optimum blend of the blended cements are preferably determined using conventional empirical methods.

The annular region may be filled with the material 1160 in sufficient quantities to ensure that, upon radial expansion of the tubular member 1110, the annular region will be filled with material 1160.

As illustrated in Fig. 10d, once the annular region has been adequately filled with material 1160, one or more plugs 1165, or other similar devices, preferably are introduced into the fluid passages 1140 thereby fluidically isolating the interior region of the tubular member 1110 from the annular region external to the tubular member 1110. A non hardenable fluidic material 1161 is then pumped into the interior region of the tubular member 1110 below the mandrel 1105 causing the interior region to pressurize. The one or more plugs 1165, or other similar devices, are introduced into the fluid passage 1140 with the introduction of the non hardenable fluidic material. In this manner, the amount of hardenable fluidic material within the interior of the tubular member 1110 is minimized.

As illustrated in Fig. 10e, once the interior region becomes sufficiently pressurized, the tubular member 1110 is extruded off of the expandable mandrel 1105. During the extrusion process, the expandable mandrel 1105 is raised out of the expanded portion of the tubular member 1110.

The plugs 1165 are preferably placed into the fluid passages 1140 by introducing the plugs 1165 into the fluid passage 1130 at a surface location in a conventional manner. The plugs 1165 may comprise any number of conventional commercially available devices from plugging a fluid passage such as, for example, brass balls, plugs, rubber balls, or darts modified in accordance with the teachings of the present disclosure.

The plugs 1165 comprise low density rubber balls. In an alternative embodiment, for a shoe 1105 having a common central inlet passage, the plugs 1165 comprise a single latch down dart.

5 After placement of the plugs 1165 in the fluid passages 1140, the non hardenable fluidic material 1161 is preferably pumped into the interior region of the tubular member 1110 below the mandrel 1105 at pressures and flow rates ranging from approximately 500 to 9,000 psi and 40 to 3,000 gallons/min.

10 After placement of the plugs 1165 in the fluid passages 1140, the non hardenable fluidic material 1161 is preferably pumped into the interior region of the tubular member 1110 below the mandrel 1105 at pressures and flow rates ranging from approximately 1200 to 8500 psi and 40 to 1250 gallons/min in order to optimally provide extrusion of typical tubulars.

15 For typical tubular members 1110, the extrusion of the tubular member 1110 off of the expandable mandrel 1105 will begin when the pressure of the interior region of the tubular member 1110 below the mandrel 1105 reaches, for example, approximately 1200 to 8500 psi. The extrusion of the tubular member 1110 off of the expandable mandrel 1105 begins when the pressure of the interior region of the tubular member 1110 below the mandrel 1105 reaches approximately 1200 to 8500 psi.

20 During the extrusion process, the expandable mandrel 1105 may be raised out of the expanded portion of the tubular member 1110 at rates ranging, for example, from about 0 to 5 ft/sec. During the extrusion process, the expandable mandrel 1105 is raised out of the expanded portion of the tubular member 1110 at rates ranging from about 0 to 2 ft/sec in order to optimally provide permit adjustment of operational parameters, and optimally ensure that the extrusion process will be completed before  
25 the material 1160 cures.

30 At least a portion 1180 of the tubular member 1110 has an internal diameter less than the outside diameter of the mandrel 1105. In this manner, when the mandrel 1105 expands the section 1180 of the tubular member 1110, at least a portion of the expanded section 1180 effects a seal with at least the wellbore casing 1012. The seal is effected by compressing the seals 1145 between the expanded section 1180 and the wellbore casing 1012. The contact pressure of the joint between the expanded section 1180 of the tubular member 1110 and the casing 1012 ranges from about 500 to 10,000



psi in order to optimally provide pressure to activate the sealing members 1145 and provide optimal resistance to ensure that the joint will withstand typical extremes of tensile and compressive loads.

Substantially all of the entire length of the tubular member 1110 has an internal diameter less than the outside diameter of the mandrel 1105. In this manner, extrusion of the tubular member 1110 by the mandrel 1105 results in contact between substantially all of the expanded tubular member 1110 and the existing casing 1008. The contact pressure of the joint between the expanded tubular member 1110 and the casings 1008 and 1012 ranges from about 500 to 10,000 psi in order to optimally provide pressure to activate the sealing members 1145 and provide optimal resistance to ensure that the joint will withstand typical extremes of tensile and compressive loads.

The operating pressure and flow rate of the material 1161 is controllably ramped down when the expandable mandrel 1105 reaches the upper end portion of the tubular member 1110. In this manner, the sudden release of pressure caused by the complete extrusion of the tubular member 1110 off of the expandable mandrel 1105 can be minimized. The operating pressure of the fluidic material 1161 is reduced in a substantially linear fashion from 100% to about 10% during the end of the extrusion process beginning when the mandrel 1105 has completed approximately all but about 5 feet of the extrusion process.

Alternatively, or in combination, a shock absorber is provided in the support member 1150 in order to absorb the shock caused by the sudden release of pressure.

Alternatively, or in combination, a mandrel catching structure is provided in the upper end portion of the tubular member 1110 in order to catch or at least decelerate the mandrel 1105.

Referring to Fig. 10f, once the extrusion process is completed, the expandable mandrel 1105 is removed from the wellbore 1000. Either before or after the removal of the expandable mandrel 1105, the integrity of the fluidic seal of the joint between the upper portion of the tubular member 1110 and the upper portion of the tubular liner 1108 is tested using conventional methods. If the fluidic seal of the joint between the upper portion of the tubular member 1110 and the upper portion of the tubular liner 1008 is satisfactory, then the uncured portion of the material 1160 within the expanded

tubular member 1110 is then removed in a conventional manner. The material 1160 within the annular region between the tubular member 1110 and the tubular liner 1008 is then allowed to cure.

As illustrated in Fig. 10f, preferably any remaining cured material 1160 within the interior of the expanded tubular member 1110 is then removed in a conventional manner using a conventional drill string. The resulting tie-back liner of casing 1170 includes the expanded tubular member 1110 and an outer annular layer 1175 of cured material 1160.

As illustrated in Fig. 10g, the remaining bottom portion of the apparatus 1100 comprising the shoe 1115 and packer 1155 is then preferably removed by drilling out the shoe 1115 and packer 1155 using conventional drilling methods.

The apparatus 1100 incorporates the apparatus 900.

Referring now to Figs. 11a-11f, an apparatus and method for hanging a tubular liner off of an existing wellbore casing will now be described. As illustrated in Fig. 11a, a wellbore 1200 is positioned in a subterranean formation 1205. The wellbore 1200 includes an existing cased section 1210 having a tubular casing 1215 and an annular outer layer of cement 1220.

In order to extend the wellbore 1200 into the subterranean formation 1205, a drill string 1225 is used in a well known manner to drill out material from the subterranean formation 1205 to form a new section 1230.

As illustrated in Fig. 11b, an apparatus 1300 for forming a wellbore casing in a subterranean formation is then positioned in the new section 1230 of the wellbore 100. The apparatus 1300 preferably includes an expandable mandrel or pig 1305, a tubular member 1310, a shoe 1315, a fluid passage 1320, a fluid passage 1330, a fluid passage 1335, seals 1340, a support member 1345, and a wiper plug 1350.

The expandable mandrel 1305 is coupled to and supported by the support member 1345. The expandable mandrel 1305 is preferably adapted to controllably expand in a radial direction. The expandable mandrel 1305 may comprise any number of conventional commercially available expandable mandrels modified in accordance with the teachings of the present disclosure. The expandable mandrel 1305 comprises a hydraulic expansion tool substantially as disclosed in U.S. Pat. No. 5,348,095, the

disclosure of which is incorporated herein by reference, modified in accordance with the teachings of the present disclosure.

The tubular member 1310 is coupled to and supported by the expandable mandrel 1305. The tubular member 1310 is preferably expanded in the radial direction and extruded off of the expandable mandrel 1305. The tubular member 1310 may be fabricated from any number of materials such as, for example, Oilfield Country Tubular Goods (OCTG), 13 chromium steel tubing/casing or plastic casing. The tubular member 1310 is fabricated from OCTG. The inner and outer diameters of the tubular member 1310 may range, for example, from approximately 0.75 to 47 inches and 1.05 to 48 inches, respectively. The inner and outer diameters of the tubular member 1310 range from about 3 to 15.5 inches and 3.5 to 16 inches, respectively in order to optimally provide minimal telescoping effect in the most commonly encountered wellbore sizes.

The tubular member 1310 includes an upper portion 1355, an intermediate portion 1360, and a lower portion 1365. The wall thickness and outer diameter of the upper portion 1355 of the tubular member 1310 range from about 3/8 to 1 2 inches and 3 2 to 16 inches, respectively. The wall thickness and outer diameter of the intermediate portion 1360 of the tubular member 1310 range from about 0.625 to 0.75 inches and 3 to 19 inches, respectively. The wall thickness and outer diameter of the lower portion 1365 of the tubular member 1310 range from about 3/8 to 1.5 inches and 3.5 to 16 inches, respectively.

The outer diameter of the lower portion 1365 of the tubular member 1310 is significantly less than the outer diameters of the upper and intermediate portions, 1355 and 1360, of the tubular member 1310 in order to optimize the formation of a concentric and overlapping arrangement of wellbore casings. In this manner, as will be described below with reference to Figs. 12 and 13, a wellhead system is optimally provided. The formation of a wellhead system does not include the use of a hardenable fluidic material.

The wall thickness of the intermediate section 1360 of the tubular member 1310 is less than or equal to the wall thickness of the upper and lower sections, 1355 and 1365, of the tubular member 1310 in order to optimally facilitate the initiation of the

extrusion process and optimally permit the placement of the apparatus in areas of the wellbore having tight clearances.

The tubular member 1310 preferably comprises a solid member. The upper end portion 1355 of the tubular member 1310 is slotted, perforated, or otherwise modified to catch or slow down the mandrel 1305 when it completes the extrusion of tubular member 1310. The length of the tubular member 1310 is limited to minimize the possibility of buckling. For typical tubular member 1310 materials, the length of the tubular member 1310 is preferably limited to between about 40 to 20,000 feet in length.

The shoe 1315 is coupled to the tubular member 1310. The shoe 1315 preferably includes fluid passages 1330 and 1335. The shoe 1315 may comprise any number of conventional commercially available shoes such as, for example, Super Seal II float shoe, Super Seal II Down-Jet float shoe or guide shoe with a sealing sleeve for a latch-down plug modified in accordance with the teachings of the present disclosure.

The shoe 1315 comprises an aluminum down-jet guide shoe with a sealing sleeve for a latch-down plug available from Halliburton Energy Services in Dallas, TX, modified in accordance with the teachings of the present disclosure, in order to optimally guide the tubular member 1310 into the wellbore 1200, optimally fluidically isolate the interior of the tubular member 1310, and optimally permit the complete drill out of the shoe 1315 upon the completion of the extrusion and cementing operations.

The shoe 1315 further includes one or more side outlet ports in fluidic communication with the fluid passage 1330. In this manner, the shoe 1315 preferably injects hardenable fluidic sealing material into the region outside the shoe 1315 and tubular member 1310. The shoe 1315 includes the fluid passage 1330 having an inlet geometry that can receive a fluidic sealing member. In this manner, the fluid passage 1330 can be sealed off by introducing a plug, dart and/or ball sealing elements into the fluid passage 1330.

The fluid passage 1320 permits fluidic materials to be transported to and from the interior region of the tubular member 1310 below the expandable mandrel 1305.

The fluid passage 1320 is coupled to and positioned within the support member 1345 and the expandable mandrel 1305. The fluid passage 1320 preferably extends from a position adjacent to the surface to the bottom of the expandable mandrel 1305. The

fluid passage 1320 is preferably positioned along a centerline of the apparatus 1300. The fluid passage 1320 is preferably selected to transport materials such as cement, drilling mud, or epoxies at flow rates and pressures ranging from about 0 to 3,000 gallons/minute and 0 to 9,000 psi in order to optimally provide sufficient operating pressures to circulate fluids at operationally efficient rates.

The fluid passage 1330 permits fluidic materials to be transported to and from the region exterior to the tubular member 1310 and shoe 1315. The fluid passage 1330 is coupled to and positioned within the shoe 1315 in fluidic communication with the interior region 1370 of the tubular member 1310 below the expandable mandrel 1305.

The fluid passage 1330 preferably has a cross-sectional shape that permits a plug, or other similar device, to be placed in fluid passage 1330 to thereby block further passage of fluidic materials. In this manner, the interior region 1370 of the tubular member 1310 below the expandable mandrel 1305 can be fluidically isolated from the region exterior to the tubular member 1310. This permits the interior region 1370 of the tubular member 1310 below the expandable mandrel 1305 to be pressurized. The fluid passage 1330 is preferably positioned substantially along the centerline of the apparatus 1300.

The fluid passage 1330 is preferably selected to convey materials such as cement, drilling mud or epoxies at flow rates and pressures ranging from about 0 to 3,000 gallons/minute and 0 to 9,000 psi in order to optimally fill the annular region between the tubular member 1310 and the new section 1230 of the wellbore 1200 with fluidic materials. The fluid passage 1330 includes an inlet geometry that can receive a dart and/or a ball sealing member. In this manner, the fluid passage 1330 can be sealed off by introducing a plug, dart and/or ball sealing elements into the fluid passage 1320.

The fluid passage 1335 permits fluidic materials to be transported to and from the region exterior to the tubular member 1310 and shoe 1315. The fluid passage 1335 is coupled to and positioned within the shoe 1315 in fluidic communication with the fluid passage 1330. The fluid passage 1335 is preferably positioned substantially along the centerline of the apparatus 1300. The fluid passage 1335 is preferably selected to convey materials such as cement, drilling mud or epoxies at flow rates and pressures ranging from about 0 to 3,000 gallons/minute and 0 to 9,000 psi in order to

optimally fill the annular region between the tubular member 1310 and the new section 1230 of the wellbore 1200 with fluidic materials.

5 The seals 1340 are coupled to and supported by the upper end portion 1355 of the tubular member 1310. The seals 1340 are further positioned on an outer surface of the upper end portion 1355 of the tubular member 1310. The seals 1340 permit the overlapping joint between the lower end portion of the casing 1215 and the upper portion 1355 of the tubular member 1310 to be fluidically sealed. The seals 1340 may comprise any number of conventional commercially available seals such as, for example, lead, rubber, Teflon, or epoxy seals modified in accordance with the teachings of the present disclosure. The seals 1340 comprise seals molded from Stratalock epoxy available from Halliburton Energy Services in Dallas, TX in order to optimally provide a hydraulic seal in the annulus of the overlapping joint while also creating optimal load bearing capability to withstand typical tensile and compressive loads.

15 The seals 1340 are selected to optimally provide a sufficient frictional force to support the expanded tubular member 1310 from the existing casing 1215. The frictional force provided by the seals 1340 ranges from about 1,000 to 1,000,000 lbf in order to optimally support the expanded tubular member 1310.

20 The support member 1345 is coupled to the expandable mandrel 1305, tubular member 1310, shoe 1315, and seals 1340. The support member 1345 preferably comprises an annular member having sufficient strength to carry the apparatus 1300 into the new section 1230 of the wellbore 1200. The support member 1345 further includes one or more conventional centralizers (not illustrated) to help stabilize the tubular member 1310.

25 The support member 1345 is thoroughly cleaned prior to assembly to the remaining portions of the apparatus 1300. In this manner, the introduction of foreign material into the apparatus 1300 is minimized. This minimizes the possibility of foreign material clogging the various flow passages and valves of the apparatus 1300 and to ensure that no foreign material interferes with the expansion process.

30 The wiper plug 1350 is coupled to the mandrel 1305 within the interior region 1370 of the tubular member 1310. The wiper plug 1350 includes a fluid passage 1375 that is coupled to the fluid passage 1320. The wiper plug 1350 may comprise one or

more conventional commercially available wiper plugs such as, for example, Multiple Stage Cementer latch-down plugs, Omega latch-down plugs or three-wiper latch-down plug modified in accordance with the teachings of the present disclosure. The wiper plug 1350 comprises a Multiple Stage Cementer latch-down plug available from  
5 Halliburton Energy Services in Dallas, TX modified in a conventional manner for releasable attachment to the expansion mandrel 1305.

Before or after positioning the apparatus 1300 within the new section 1230 of the wellbore 1200, a couple of wellbore volumes are circulated in order to ensure that no foreign materials are located within the wellbore 1200 that might clog up the  
10 various flow passages and valves of the apparatus 1300 and to ensure that no foreign material interferes with the extrusion process.

As illustrated in Fig. 11c, a hardenable fluidic sealing material 1380 is then pumped from a surface location into the fluid passage 1320. The material 1380 then passes from the fluid passage 1320, through the fluid passage 1375, and into the  
15 interior region 1370 of the tubular member 1310 below the expandable mandrel 1305. The material 1380 then passes from the interior region 1370 into the fluid passage 1330. The material 1380 then exits the apparatus 1300 via the fluid passage 1335 and fills the annular region 1390 between the exterior of the tubular member 1310 and the interior wall of the new section 1230 of the wellbore 1200. Continued pumping of the  
20 material 1380 causes the material 1380 to fill up at least a portion of the annular region 1390.

The material 1380 may be pumped into the annular region 1390 at pressures and flow rates ranging, for example, from about 0 to 5000 psi and 0 to 1,500 gallons/min, respectively. The material 1380 is pumped into the annular region 1390  
25 at pressures and flow rates ranging from about 0 to 5000 psi and 0 to 1,500 gallons/min, respectively, in order to optimally fill the annular region between the tubular member 1310 and the new section 1230 of the wellbore 1200 with the hardenable fluidic sealing material 1380.

The hardenable fluidic sealing material 1380 may comprise any number of  
30 conventional commercially available hardenable fluidic sealing materials such as, for example, slag mix, cement or epoxy. The hardenable fluidic sealing material 1380 comprises blended cements designed specifically for the well section being drilled and

available from Halliburton Energy Services in order to optimally provide support for the tubular member 1310 during displacement of the material 1380 in the annular region 1390. The optimum blend of the cement is preferably determined using conventional empirical methods.

5 The annular region 1390 preferably is filled with the material 1380 in sufficient quantities to ensure that, upon radial expansion of the tubular member 1310, the annular region 1390 of the new section 1230 of the wellbore 1200 will be filled with material 1380.

10 As illustrated in Fig. 11d, once the annular region 1390 has been adequately filled with material 1380, a wiper dart 1395, or other similar device, is introduced into the fluid passage 1320. The wiper dart 1395 is preferably pumped through the fluid passage 1320 by a non hardenable fluidic material 1381. The wiper dart 1395 then preferably engages the wiper plug 1350.

15 As illustrated in Fig. 11e, engagement of the wiper dart 1395 with the wiper plug 1350 causes the wiper plug 1350 to decouple from the mandrel 1305. The wiper dart 1395 and wiper plug 1350 then preferably will lodge in the fluid passage 1330, thereby blocking fluid flow through the fluid passage 1330, and fluidically isolating the interior region 1370 of the tubular member 1310 from the annular region 1390. The non hardenable fluidic material 1381 is then pumped into the interior region 1370  
20 causing the interior region 1370 to pressurize. Once the interior region 1370 becomes sufficiently pressurized, the tubular member 1310 is extruded off of the expandable mandrel 1305. During the extrusion process, the expandable mandrel 1305 is raised out of the expanded portion of the tubular member 1310 by the support member 1345.

25 The wiper dart 1395 is preferably placed into the fluid passage 1320 by introducing the wiper dart 1395 into the fluid passage 1320 at a surface location in a conventional manner. The wiper dart 1395 may comprise any number of conventional commercially available devices from plugging a fluid passage such as, for example, Multiple Stage Cementer latch-down plugs, Omega latch-down plugs or three wiper latch-down plug/dart modified in accordance with the teachings of the present  
30 disclosure. The wiper dart 1395 comprises a three wiper latch-down plug modified to latch and seal in the Multiple Stage Cementer latch down plug 1350. The three wiper latch-down plug is available from Halliburton Energy Services in Dallas, TX.



After blocking the fluid passage 1330 using the wiper plug 1330 and wiper dart 1395, the non hardenable fluidic material 1381 may be pumped into the interior region 1370 at pressures and flow rates ranging, for example, from approximately 0 to 5000 psi and 0 to 1,500 gallons/min in order to optimally extrude the tubular member 1310 off of the mandrel 1305. In this manner, the amount of hardenable fluidic material within the interior of the tubular member 1310 is minimized.

After blocking the fluid passage 1330, the non hardenable fluidic material 1381 is preferably pumped into the interior region 1370 at pressures and flow rates ranging from approximately 500 to 9,000 psi and 40 to 3,000 gallons/min in order to optimally provide operating pressures to maintain the expansion process at rates sufficient to permit adjustments to be made in operating parameters during the extrusion process.

For typical tubular members 1310, the extrusion of the tubular member 1310 off of the expandable mandrel 1305 will begin when the pressure of the interior region 1370 reaches, for example, approximately 500 to 9,000 psi. The extrusion of the tubular member 1310 off of the expandable mandrel 1305 is a function of the tubular member diameter, wall thickness of the tubular member, geometry of the mandrel, the type of lubricant, the composition of the shoe and tubular member, and the yield strength of the tubular member. The optimum flow rate and operating pressures are preferably determined using conventional empirical methods.

During the extrusion process, the expandable mandrel 1305 may be raised out of the expanded portion of the tubular member 1310 at rates ranging, for example, from about 0 to 5 ft/sec. During the extrusion process, the expandable mandrel 1305 is raised out of the expanded portion of the tubular member 1310 at rates ranging from about 0 to 2 ft/sec in order to optimally provide an efficient process, optimally permit operator adjustment of operation parameters, and ensure optimal completion of the extrusion process before curing of the material 1380.

When the upper end portion 1355 of the tubular member 1310 is extruded off of the expandable mandrel 1305, the outer surface of the upper end portion 1355 of the tubular member 1310 will preferably contact the interior surface of the lower end portion of the casing 1215 to form an fluid tight overlapping joint. The contact pressure of the overlapping joint may range, for example, from approximately 50 to 20,000 psi. The contact pressure of the overlapping joint ranges from approximately

400 to 10,000 psi in order to optimally provide contact pressure sufficient to ensure annular sealing and provide enough resistance to withstand typical tensile and compressive loads. The sealing members 1340 will ensure an adequate fluidic and gaseous seal in the overlapping joint.

5           The operating pressure and flow rate of the non hardenable fluidic material 1381 is controllably ramped down when the expandable mandrel 1305 reaches the upper end portion 1355 of the tubular member 1310. In this manner, the sudden release of pressure caused by the complete extrusion of the tubular member 1310 off of the expandable mandrel 1305 can be minimized. The operating pressure is reduced in  
10 a substantially linear fashion from 100% to about 10% during the end of the extrusion process beginning when the mandrel 1305 has completed approximately all but about 5 feet of the extrusion process.

          Alternatively, or in combination, a shock absorber is provided in the support member 1345 in order to absorb the shock caused by the sudden release of pressure.

15           Alternatively, or in combination, a mandrel catching structure is provided in the upper end portion 1355 of the tubular member 1310 in order to catch or at least decelerate the mandrel 1305.

          Once the extrusion process is completed, the expandable mandrel 1305 is removed from the wellbore 1200. Either before or after the removal of the expandable  
20 mandrel 1305, the integrity of the fluidic seal of the overlapping joint between the upper portion 1355 of the tubular member 1310 and the lower portion of the casing 1215 is tested using conventional methods. If the fluidic seal of the overlapping joint between the upper portion 1355 of the tubular member 1310 and the lower portion of the casing 1215 is satisfactory, then the uncured portion of the material 1380 within the  
25 expanded tubular member 1310 is then removed in a conventional manner. The material 1380 within the annular region 1390 is then allowed to cure.

          As illustrated in Fig. 11f, preferably any remaining cured material 1380 within the interior of the expanded tubular member 1310 is then removed in a conventional manner using a conventional drill string. The resulting new section of casing 1400  
30 includes the expanded tubular member 1310 and an outer annular layer 1405 of cured material 305. The bottom portion of the apparatus 1300 comprising the shoe 1315 may then be removed by drilling out the shoe 1315 using conventional drilling methods.

Referring now to Figs. 12 and 13, a wellhead system 1500 formed using one or more of the apparatus and processes described above with reference to Figs. 1-11f will be described. The wellhead system 1500 preferably includes a conventional Christmas tree/drilling spool assembly 1505, a thick wall casing 1510, an annular body of cement 1515, an outer casing 1520, an annular body of cement 1525, an intermediate casing 1530, and an inner casing 1535.

The Christmas tree/drilling spool assembly 1505 may comprise any number of conventional Christmas tree/drilling spool assemblies such as, for example, the SS-15 Subsea Wellhead System, Spool Tree Subsea Production System or the Compact Wellhead System available from suppliers such as Dril-Quip, Cameron or Breda, modified in accordance with the teachings of the present disclosure. The drilling spool assembly 1505 is preferably operably coupled to the thick wall casing 1510 and/or the outer casing 1520. The assembly 1505 may be coupled to the thick wall casing 1510 and/or outer casing 1520, for example, by welding, a threaded connection or made from single stock. The assembly 1505 is coupled to the thick wall casing 1510 and/or outer casing 1520 by welding.

The thick wall casing 1510 is positioned in the upper end of a wellbore 1540. At least a portion of the thick wall casing 1510 extends above the surface 1545 in order to optimally provide easy access and attachment to the Christmas tree/drilling spool assembly 1505. The thick wall casing 1510 is preferably coupled to the Christmas tree/drilling spool assembly 1505, the annular body of cement 1515, and the outer casing 1520.

The thick wall casing 1510 may comprise any number of conventional commercially available high strength wellbore casings such as, for example, Oilfield Country Tubular Goods, titanium tubing or stainless steel tubing. The thick wall casing 1510 comprises Oilfield Country Tubular Goods available from various foreign and domestic steel mills. The thick wall casing 1510 has a yield strength of about 40,000 to 135,000 psi in order to optimally provide maximum burst, collapse, and tensile strengths. The thick wall casing 1510 has a failure strength in excess of about 5,000 to 20,000 psi in order to optimally provide maximum operating capacity and resistance to degradation of capacity after being drilled through for an extended time period.

5 The annular body of cement 1515 provides support for the thick wall casing 1510. The annular body of cement 1515 may be provided using any number of conventional processes for forming an annular body of cement in a wellbore. The annular body of cement 1515 may comprise any number of conventional cement mixtures.

10 The outer casing 1520 is coupled to the thick wall casing 1510. The outer casing 1520 may be fabricated from any number of conventional commercially available tubular members modified in accordance with the teachings of the present disclosure. The outer casing 1520 comprises any one of the expandable tubular members described above with reference to Figs. 1-11f.

15 The outer casing 1520 is coupled to the thick wall casing 1510 by expanding the outer casing 1520 into contact with at least a portion of the interior surface of the thick wall casing 1510 using any one of the embodiments of the processes and apparatus described above with reference to Figs. 1-11f. In an alternative embodiment, substantially all of the overlap of the outer casing 1520 with the thick wall casing 1510 contacts with the interior surface of the thick wall casing 1510.

20 The contact pressure of the interface between the outer casing 1520 and the thick wall casing 1510 may range, for example, from about 500 to 10,000 psi. The contact pressure between the outer casing 1520 and the thick wall casing 1510 ranges from about 500 to 10,000 psi in order to optimally activate the pressure activated sealing members and to ensure that the overlapping joint will optimally withstand typical extremes of tensile and compressive loads that are experienced during drilling and production operations.

25 As illustrated in Fig. 13, the upper end of the outer casing 1520 includes one or more sealing members 1550 that provide a gaseous and fluidic seal between the expanded outer casing 1520 and the interior wall of the thick wall casing 1510. The sealing members 1550 may comprise any number of conventional commercially available seals such as, for example, lead, plastic, rubber, Teflon or epoxy, modified in accordance with the teachings of the present disclosure. The sealing members 1550  
30 comprise seals molded from StrataLock epoxy available from Halliburton Energy Services in order to optimally provide an hydraulic seal and a load bearing interference fit between the tubular members. The contact pressure of the interface between the

thick wall casing 1510 and the outer casing 1520 ranges from about 500 to 10,000 psi in order to optimally activate the sealing members 1550 and also optimally ensure that the joint will withstand the typical operating extremes of tensile and compressive loads during drilling and production operations.

5           The outer casing 1520 and the thick walled casing 1510 are combined in one unitary member.

          The annular body of cement 1525 provides support for the outer casing 1520. The annular body of cement 1525 is provided using any one of the embodiments of the apparatus and processes described above with reference to Figs. 1-11f.

10           The intermediate casing 1530 may be coupled to the outer casing 1520 or the thick wall casing 1510. The intermediate casing 1530 is coupled to the thick wall casing 1510. The intermediate casing 1530 may be fabricated from any number of conventional commercially available tubular members modified in accordance with the teachings of the present disclosure. The intermediate casing 1530 comprises any one  
15 of the expandable tubular members described above with reference to Figs. 1-11f.

          The intermediate casing 1530 is coupled to the thick wall casing 1510 by expanding at least a portion of the intermediate casing 1530 into contact with the interior surface of the thick wall casing 1510 using any one of the processes and apparatus described above with reference to Figs. 1-11f. The entire length of the  
20 overlap of the intermediate casing 1530 with the thick wall casing 1510 contacts the inner surface of the thick wall casing 1510. The contact pressure of the interface between the intermediate casing 1530 and the thick wall casing 1510 may range, for example from about 500 to 10,000 psi. The contact pressure between the intermediate casing 1530 and the thick wall casing 1510 ranges from about 500 to 10,000 psi in  
25 order to optimally activate the pressure activated sealing members and to optimally ensure that the joint will withstand typical operating extremes of tensile and compressive loads experienced during drilling and production operations.

          As illustrated in Fig. 13, the upper end of the intermediate casing 1530 includes one or more sealing members 1560 that provide a gaseous and fluidic seal between the  
30 expanded end of the intermediate casing 1530 and the interior wall of the thick wall casing 1510. The sealing members 1560 may comprise any number of conventional commercially available seals such as, for example, plastic, lead, rubber, Teflon or

epoxy, modified in accordance with the teachings of the present disclosure. The sealing members 1560 comprise seals molded from StrataLock epoxy available from Halliburton Energy Services in order to optimally provide a hydraulic seal and a load bearing interference fit between the tubular members.

5 The contact pressure of the interface between the expanded end of the intermediate casing 1530 and the thick wall casing 1510 ranges from about 500 to 10,000 psi in order to optimally activate the sealing members 1560 and also optimally ensure that the joint will withstand typical operating extremes of tensile and compressive loads that are experienced during drilling and production operations.

10 The inner casing 1535 may be coupled to the outer casing 1520 or the thick wall casing 1510. The inner casing 1535 is coupled to the thick wall casing 1510. The inner casing 1535 may be fabricated from any number of conventional commercially available tubular members modified in accordance with the teachings of the present disclosure. The inner casing 1535 comprises any one of the expandable tubular  
15 members described above with reference to Figs. 1-11f.

The inner casing 1535 is coupled to the outer casing 1520 by expanding at least a portion of the inner casing 1535 into contact with the interior surface of the thick wall casing 1510 using any one of the processes and apparatus described above with reference to Figs. 1-11f. The entire length of the overlap of the inner casing 1535 with  
20 the thick wall casing 1510 and intermediate casing 1530 contacts the inner surfaces of the thick wall casing 1510 and intermediate casing 1530. The contact pressure of the interface between the inner casing 1535 and the thick wall casing 1510 may range, for example from about 500 to 10,000 psi. The contact pressure between the inner casing 1535 and the thick wall casing 1510 ranges from about 500 to 10,000 psi in order to  
25 optimally activate the pressure activated sealing members and to ensure that the joint will withstand typical extremes of tensile and compressive loads that are commonly experienced during drilling and production operations.

As illustrated in Fig. 13, the upper end of the inner casing 1535 includes one or more sealing members 1570 that provide a gaseous and fluidic seal between the  
30 expanded end of the inner casing 1535 and the interior wall of the thick wall casing 1510. The sealing members 1570 may comprise any number of conventional commercially available seals such as, for example, lead, plastic, rubber, Teflon or

epoxy, modified in accordance with the teachings of the present disclosure. The sealing members 1570 comprise seals molded from StrataLock epoxy available from Halliburton Energy Services in order to optimally provide an hydraulic seal and a load bearing interference fit. The contact pressure of the interface between the expanded end of the inner casing 1535 and the thick wall casing 1510 ranges from about 500 to 10,000 psi in order to optimally activate the sealing members 1570 and also to optimally ensure that the joint will withstand typical operating extremes of tensile and compressive loads that are experienced during drilling and production operations.

In an alternative embodiment, the inner casings, 1520, 1530 and 1535, may be coupled to a previously positioned tubular member that is in turn coupled to the outer casing 1510. Such arrangements may be used to form a concentric disposition of tubular members.

Referring now to Figures 14a, 14b, 14c, 14d, 14e and 14f, a method and apparatus for forming a mono-diameter well casing within a subterranean formation will now be described.

As illustrated in Fig. 14a, a wellbore 1600 is positioned in a subterranean formation 1605. A first section of casing 1610 is formed in the wellbore 1600. The first section of casing 1610 includes an annular outer body of cement 1615 and a tubular section of casing 1620. The first section of casing 1610 may be formed in the wellbore 1600 using conventional methods and apparatus. The first section of casing 1610 is formed using one or more of the methods and apparatus described above with reference to Figs. 1-13 or below with reference to Figs. 14b-17b.

The annular body of cement 1615 may comprise any number of conventional commercially available cement, or other load bearing, compositions. Alternatively, the body of cement 1615 may be omitted or replaced with an epoxy mixture.

The tubular section of casing 1620 preferably includes an upper end 1625 and a lower end 1630. Preferably, the lower end 1625 of the tubular section of casing 1620 includes an outer annular recess 1635 extending from the lower end 1630 of the tubular section of casing 1620. In this manner, the lower end 1625 of the tubular section of casing 1620 includes a thin walled section 1640. An annular body 1645 of a compressible material is coupled to and at least partially positioned within the outer

annular recess 1635. In this manner, the body of compressible material 1645 surrounds at least a portion of the thin walled section 1640.

The tubular section of casing 1620 may be fabricated from any number of conventional commercially available materials such as, for example, oilfield country tubular goods, stainless steel, automotive grade steel, carbon steel, low alloy steel, fiberglass or plastics. The tubular section of casing 1620 is fabricated from oilfield country tubular goods available from various foreign and domestic steel mills. The wall thickness of the thin walled section 1640 may range from about 0.125 to 1.5 inches. The wall thickness of the thin walled section 1640 ranges from 0.25 to 1.0 inches in order to optimally provide burst strength for typical operational conditions while also minimizing resistance to radial expansion. The axial length of the thin walled section 1640 may range from about 120 to 2400 inches. The axial length of the thin walled section 1640 ranges from about 240 to 480 inches.

The annular body of compressible material 1645 helps to minimize the radial force required to expand the tubular casing 1620 in the overlap with the tubular member 1715, helps to create a fluidic seal in the overlap with the tubular member 1715, and helps to create an interference fit sufficient to permit the tubular member 1715 to be supported by the tubular casing 1620. The annular body of compressible material 1645 may comprise any number of commercially available compressible materials such as, for example, epoxy, rubber, Teflon, plastics or lead tubes. The annular body of compressible material 1645 comprises StrataLock epoxy available from Halliburton Energy Services in order to optimally provide an hydraulic seal in the overlapped joint while also having compliance to thereby minimize the radial force required to expand the tubular casing. The wall thickness of the annular body of compressible material 1645 may range from about 0.05 to 0.75 inches. The wall thickness of the annular body of compressible material 1645 ranges from about 0.1 to 0.5 inches in order to optimally provide a large compressible zone, minimize the radial forces required to expand the tubular casing, provide thickness for casing strings to provide contact with the inner surface of the wellbore upon radial expansion, and provide an hydraulic seal.

As illustrated in Fig. 14b, in order to extend the wellbore 1600 into the subterranean formation 1605, a drill string is used in a well known manner to drill out



material from the subterranean formation 1605 to form a new wellbore section 1650. The diameter of the new section 1650 is preferably equal to or greater than the inner diameter of the tubular section of casing 1620.

As illustrated in Fig. 14c, an apparatus 1700 for forming a mono-diameter wellbore casing in a subterranean formation is then positioned in the new section 1650 of the wellbore 1600. The apparatus 1700 preferably includes a support member 1705, an expandable mandrel or pig 1710, a tubular member 1715, a shoe 1720, slips 1725, a fluid passage 1730, one or more fluid passages 1735, a fluid passage 1740, a first compressible annular body 1745, a second compressible annular body 1750, and a pressure chamber 1755.

The support member 1705 supports the apparatus 1700 within the wellbore 1600. The support member 1705 is coupled to the mandrel 1710, the tubular member 1715, the shoe 1720, and the slips 1725. The support member 1075 preferably comprises a substantially hollow tubular member. The fluid passage 1730 is positioned within the support member 1705. The fluid passages 1735 fluidically couple the fluid passage 1730 with the pressure chamber 1755. The fluid passage 1740 fluidically couples the fluid passage 1730 with the region outside of the apparatus 1700.

The support member 1705 may be fabricated from any number of conventional commercially available materials such as, for example, oilfield country tubular goods, stainless steel, low alloy steel, carbon steel, 13 chromium steel, fiberglass, or other high strength materials. The support member 1705 is fabricated from oilfield country tubular goods available from various foreign and domestic steel mills in order to optimally provide operational strength and facilitate the use of other standard oil exploration handling equipment. At least a portion of the support member 1705 comprises coiled tubing or a drill pipe. The support member 1705 includes a load shoulder 1820 for supporting the mandrel 1710 when the pressure chamber 1755 is unpressurized.

The mandrel 1710 is supported by and slidingly coupled to the support member 1705 and the shoe 1720. The mandrel 1710 preferably includes an upper portion 1760 and a lower portion 1765. Preferably, the upper portion 1760 of the mandrel 1710 and the support member 1705 together define the pressure chamber 1755. Preferably, the

lower portion 1765 of the mandrel 1710 includes an expansion member 1770 for radially expanding the tubular member 1715.

The upper portion 1760 of the mandrel 1710 includes a tubular member 1775 having an inner diameter greater than an outer diameter of the support member 1705. In this manner, an annular pressure chamber 1755 is defined by and positioned between the tubular member 1775 and the support member 1705. The top 1780 of the tubular member 1775 preferably includes a bearing and a seal for sealing and supporting the top 1780 of the tubular member 1775 against the outer surface of the support member 1705. The bottom 1785 of the tubular member 1775 preferably includes a bearing and seal for sealing and supporting the bottom 1785 of the tubular member 1775 against the outer surface of the support member 1705 or shoe 1720. In this manner, the mandrel 1710 moves in an axial direction upon the pressurization of the pressure chamber 1755.

The lower portion 1765 of the mandrel 1710 preferably includes an expansion member 1770 for radially expanding the tubular member 1715 during the pressurization of the pressure chamber 1755. The expansion member is expandible in the radial direction. The inner surface of the lower portion 1765 of the mandrel 1710 mates with and slides with respect to the outer surface of the shoe 1720. The outer diameter of the expansion member 1770 may range from about 90 to 100 % of the inner diameter of the tubular casing 1620. The outer diameter of the expansion member 1770 ranges from about 95 to 99 % of the inner diameter of the tubular casing 1620. The expansion member 1770 may be fabricated from any number of conventional commercially available materials such as, for example, machine tool steel, ceramics, tungsten carbide, titanium or other high strength alloys. The expansion member 1770 is fabricated from D2 machine tool steel in order to optimally provide high strength and abrasion resistance.

The tubular member 1715 is coupled to and supported by the support member 1705 and slips 1725. The tubular member 1715 includes an upper portion 1790 and a lower portion 1795.

The upper portion 1790 of the tubular member 1715 preferably includes an inner annular recess 1800 that extends from the upper portion 1790 of the tubular member 1715. In this manner, at least a portion of the upper portion 1790 of the

tubular member 1715 includes a thin walled section 1805. The first compressible annular member 1745 is preferably coupled to and supported by the outer surface of the upper portion 1790 of the tubular member 1715 in opposing relation to the thin wall section 1805.

5 The lower portion 1795 of the tubular member 1715 preferably includes an outer annular recess 1810 that extends from the lower portion 1790 of the tubular member 1715. In this manner, at least a portion of the lower portion 1795 of the tubular member 1715 includes a thin walled section 1815. The second compressible annular member 1750 is coupled to and at least partially supported within the outer  
10 annular recess 1810 of the upper portion 1790 of the tubular member 1715 in opposing relation to the thin wall section 1815.

The tubular member 1715 may be fabricated from any number of conventional commercially available materials such as, for example, oilfield country tubular goods, stainless steel, low alloy steel, carbon steel, automotive grade steel, fiberglass, 13  
15 chrome steel, other high strength material, or high strength plastics. The tubular member 1715 is fabricated from oilfield country tubular goods available from various foreign and domestic steel mills in order to optimally provide operational strength.

The shoe 1720 is supported by and coupled to the support member 1705. The shoe 1720 preferably comprises a substantially hollow tubular member. The wall  
20 thickness of the shoe 1720 is greater than the wall thickness of the support member 1705 in order to optimally provide increased radial support to the mandrel 1710. The shoe 1720 may be fabricated from any number of conventional commercially available materials such as, for example, oilfield country tubular goods, stainless steel, automotive grade steel, low alloy steel, carbon steel, or high strength plastics. The  
25 shoe 1720 is fabricated from oilfield country tubular goods available from various foreign and domestic steel mills in order to optimally provide matching operational strength throughout the apparatus.

The slips 1725 are coupled to and supported by the support member 1705. The slips 1725 removably support the tubular member 1715. In this manner, during the  
30 radial expansion of the tubular member 1715, the slips 1725 help to maintain the tubular member 1715 in a substantially stationary position by preventing upward movement of the tubular member 1715.

The slips 1725 may comprise any number of conventional commercially available slips such as, for example, RTTS packer tungsten carbide mechanical slips, RTTS packer wicker type mechanical slips, or Model 3L retrievable bridge plug tungsten carbide upper mechanical slips. The slips 1725 comprise RTTS packer tungsten carbide mechanical slips available from Halliburton Energy Services. The slips 1725 are adapted to support axial forces ranging from about 0 to 750,000 lbf.

The fluid passage 1730 conveys fluidic materials from a surface location into the interior of the support member 1705, the pressure chamber 1755, and the region exterior of the apparatus 1700. The fluid passage 1730 is fluidically coupled to the pressure chamber 1755 by the fluid passages 1735. The fluid passage 1730 is fluidically coupled to the region exterior to the apparatus 1700 by the fluid passage 1740.

The fluid passage 1730 is adapted to convey fluidic materials such as, for example, cement, epoxy, drilling muds, slag mix, water or drilling gasses. The fluid passage 1730 is adapted to convey fluidic materials at flow rate and pressures ranging from about 0 to 3,000 gallons/minute and 0 to 9,000 psi. in order to optimally provide flow rates and operational pressures for the radial expansion processes.

The fluid passages 1735 convey fluidic material from the fluid passage 1730 to the pressure chamber 1755. The fluid passage 1735 is adapted to convey fluidic materials such as, for example, cement, epoxy, drilling muds, water or drilling gasses. The fluid passage 1735 is adapted to convey fluidic materials at flow rate and pressures ranging from about 0 to 500 gallons/minute and 0 to 9,000 psi. in order to optimally provide operating pressures and flow rates for the various expansion processes.

The fluid passage 1740 conveys fluidic materials from the fluid passage 1730 to the region exterior to the apparatus 1700. The fluid passage 1740 is adapted to convey fluidic materials such as, for example, cement, epoxy, drilling muds, water or drilling gasses. The fluid passage 1740 is adapted to convey fluidic materials at flow rate and pressures ranging from about 0 to 3,000 gallons/minute and 0 to 9,000 psi. in order to optimally provide operating pressures and flow rates for the various radial expansion processes.

The fluid passage 1740 is adapted to receive a plug or other similar device for sealing the fluid passage 1740. In this manner, the pressure chamber 1755 may be pressurized.

5 The first compressible annular body 1745 is coupled to and supported by an exterior surface of the upper portion 1790 of the tubular member 1715. The first compressible annular body 1745 is positioned in opposing relation to the thin walled section 1805 of the tubular member 1715.

10 The first compressible annular body 1745 helps to minimize the radial force required to expand the tubular member 1715 in the overlap with the tubular casing 1620, helps to create a fluidic seal in the overlap with the tubular casing 1620, and helps to create an interference fit sufficient to permit the tubular member 1715 to be supported by the tubular casing 1620. The first compressible annular body 1745 may comprise any number of commercially available compressible materials such as, for example, epoxy, rubber, Teflon, plastics, or hollow lead tubes. The first compressible  
15 annular body 1745 comprises StrataLock epoxy available from Halliburton Energy Services in order to optimally provide an hydraulic seal, and compressibility to minimize the radial expansion force.

The wall thickness of the first compressible annular body 1745 may range from about 0.05 to 0.75 inches. The wall thickness of the first compressible annular body  
20 1745 ranges from about 0.1 to 0.5 inches in order to optimally (1) provide a large compressible zone, (2) minimize the required radial expansion force, (3) transfer the radial force to the tubular casings. As a result, overall the outer diameter of the tubular member 1715 is approximately equal to the overall inner diameter of the tubular member 1620.

25 The second compressible annular body 1750 is coupled to and at least partially supported within the outer annular recess 1810 of the tubular member 1715. The second compressible annular body 1750 is positioned in opposing relation to the thin walled section 1815 of the tubular member 1715.

30 The second compressible annular body 1750 helps to minimize the radial force required to expand the tubular member 1715 in the overlap with another tubular member, helps to create a fluidic seal in the overlap of the tubular member 1715 with another tubular member, and helps to create an interference fit sufficient to permit



another tubular member to be supported by the tubular member 1715. The second compressible annular body 1750 may comprise any number of commercially available compressible materials such as, for example, epoxy, rubber, Teflon, plastics or hollow lead tubing. The first compressible annular body 1750 comprises Stratalock epoxy available from Halliburton Energy Services in order to optimally provide an hydraulic seal in the overlapped joint, and compressibility that minimizes the radial expansion force.

The wall thickness of the second compressible annular body 1750 may range from about 0.05 to 0.75 inches. The wall thickness of the second compressible annular body 1750 ranges from about 0.1 to 0.5 inches in order to optimally provide a large compressible zone, and minimize the radial force required to expand the tubular member 1715 during subsequent radial expansion operations.

In an alternative embodiment, the outside diameter of the second compressible annular body 1750 is adapted to provide a seal against the surrounding formation thereby eliminating the need for an outer annular body of cement.

The pressure chamber 1755 is fluidically coupled to the fluid passage 1730 by the fluid passages 1735. The pressure chamber 1755 is preferably adapted to receive fluidic materials such as, for example, drilling muds, water or drilling gases. The pressure chamber 1755 is adapted to receive fluidic materials at flow rate and pressures ranging from about 0 to 500 gallons/minute and 0 to 9,000 psi. in order to optimally provide expansion pressure. During pressurization of the pressure chamber 1755, the operating pressure of the pressure chamber ranges from about 0 to 5,000 psi in order to optimally provide expansion pressure while minimizing the possibility of a catastrophic failure due to over pressurization.

As illustrated in Fig. 14d, the apparatus 1700 is preferably positioned in the wellbore 1600 with the tubular member 1715 positioned in an overlapping relationship with the tubular casing 1620. The thin wall sections, 1640 and 1805, of the tubular casing 1620 and tubular member 1725 are positioned in opposing overlapping relation.

In this manner, the radial expansion of the tubular member 1725 will compress the thin wall sections, 1640 and 1805, and annular compressible members, 1645 and 1745, into intimate contact.

After positioning of the apparatus 1700, a fluidic material 1825 is then pumped into the fluid passage 1730. The fluidic material 1825 may comprise any number of conventional commercially available materials such as, for example, water, drilling mud, drilling gases, cement or epoxy. The fluidic material 1825 comprises a  
5 hardenable fluidic sealing material such as, for example, cement in order to provide an outer annular body around the expanded tubular member 1715.

The fluidic material 1825 may be pumped into the fluid passage 1730 at operating pressures and flow rates, for example, ranging from about 0 to 9,000 psi and 0 to 3,000 gallons/minute.

10 The fluidic material 1825 pumped into the fluid passage 1730 passes through the fluid passage 1740 and outside of the apparatus 1700. The fluidic material 1825 fills the annular region 1830 between the outside of the apparatus 1700 and the interior walls of the wellbore 1600.

As illustrated in Fig. 14e, a plug 1835 is then introduced into the fluid passage  
15 1730. The plug 1835 lodges in the inlet to the fluid passage 1740 fluidically isolating and blocking off the fluid passage 1730.

A fluidic material 1840 is then pumped into the fluid passage 1730. The fluidic material 1840 may comprise any number of conventional commercially available materials such as, for example, water, drilling mud or drilling gases. The fluidic  
20 material 1840 comprises a non-hardenable fluidic material such as, for example, drilling mud or drilling gases in order to optimally provide pressurization of the pressure chamber 1755.

The fluidic material 1840 may be pumped into the fluid passage 1730 at operating pressures and flow rates ranging, for example, from about 0 to 9,000 psi and  
25 0 to 500 gallons/minute. The fluidic material 1840 is pumped into the fluid passage 1730 at operating pressures and flow rates ranging from about 500 to 5,000 psi and 0 to 500 gallons/minute in order to optimally provide operating pressures and flow rates for radial expansion.

The fluidic material 1840 pumped into the fluid passage 1730 passes through  
30 the fluid passages 1735 and into the pressure chamber 1755. Continued pumping of the fluidic material 1840 pressurizes the pressure chamber 1755. The pressurization of the pressure chamber 1755 causes the mandrel 1710 to move relative to the support

member 1705 in the direction indicated by the arrows 1845. In this manner, the mandrel 1710 will cause the tubular member 1715 to expand in the radial direction.

During the radial expansion process, the tubular member 1715 is prevented from moving in an upward direction by the slips 1725. A length of the tubular member 1715 is then expanded in the radial direction through the pressurization of the pressure chamber 1755. The length of the tubular member 1715 that is expanded during the expansion process will be proportional to the stroke length of the mandrel 1710. Upon the completion of a stroke, the operating pressure of the pressure chamber 1755 is then reduced and the mandrel 1710 drops to its rest position with the tubular member 1715 supported by the mandrel 1715. The position of the support member 1705 may be adjusted throughout the radial expansion process in order to maintain the overlapping relationship between the thin walled sections, 1640 and 1805, of the tubular casing 1620 and tubular member 1715. The stroking of the mandrel 1710 is then repeated, as necessary, until the thin walled section 1805 of the tubular member 1715 is expanded into the thin walled section 1640 of the tubular casing 1620.

During the final stroke of the mandrel 1710, the slips 1725 are positioned as close as possible to the thin walled section 1805 of the tubular member 1715 in order to minimize slippage between the tubular member 1715 and tubular casing 1620 at the end of the radial expansion process. Alternatively, or in addition, the outside diameter of the first compressive annular member 1745 is selected to ensure sufficient interference fit with the tubular casing 1620 to prevent axial displacement of the tubular member 1715 during the final stroke. Alternatively, or in addition, the outside diameter of the second compressive annular body 1750 is large enough to provide an interference fit with the inside walls of the wellbore 1600 at an earlier point in the radial expansion process so as to prevent further axial displacement of the tubular member 1715. In this final alternative, the interference fit is preferably selected to permit expansion of the tubular member 1715 by pulling the mandrel 1710 out of the wellbore 1600, without having to pressurize the pressure chamber 1755.

During the radial expansion process, the pressurized areas of the apparatus 1700 are limited to the fluid passages 1730 within the support member 1705 and the pressure chamber 1755 within the mandrel 1710. No fluid pressure acts directly on the



tubular member 1715. This permits the use of operating pressures higher than the tubular member 1715 could normally withstand.

Once the tubular member 1715 has been completely expanded off of the mandrel 1710, the support member 1705 and mandrel 1710 are removed from the wellbore 1600. The contact pressure between the deformed thin wall sections, 1640 and 1805, and compressible annular members, 1645 and 1745, ranges from about 400 to 10,000 psi in order to optimally support the tubular member 1715 using the tubular casing 1620.

In this manner, the tubular member 1715 is radially expanded into contact with the tubular casing 1620 by pressurizing the interior of the fluid passage 1730 and the pressure chamber 1755.

As illustrated in Fig. 14f, once the tubular member 1715 is completely expanded in the radial direction by the mandrel 1710, the support member 1705 and mandrel 1710 are removed from the wellbore 1600. The annular body of hardenable fluidic material is then allowed to cure to form a rigid outer annular body 1850. In the case where the tubular member 1715 is slotted, the hardenable fluidic material will preferably permeate and envelop the expanded tubular member 1715.

The resulting new section of wellbore casing 1855 includes the expanded tubular member 1715 and the rigid outer annular body 1850. The overlapping joint 1860 between the tubular casing 1620 and the expanded tubular member 1715 includes the deformed thin wall sections, 1640 and 1805, and the compressible annular bodies, 1645 and 1745. The inner diameter of the resulting combined wellbore casings is substantially constant. In this manner, a mono-diameter wellbore casing is formed. This process of expanding overlapping tubular members having thin wall end portions with compressible annular bodies into contact can be repeated for the entire length of a wellbore. In this manner, a mono-diameter wellbore casing can be provided for thousands of feet in a subterranean formation.

Referring now to Figures 15, 15a and 15b, an apparatus 1900 for expanding a tubular member will be described. The apparatus 1900 preferably includes a drillpipe 1905, an innerstring adapter 1910, a sealing sleeve 1915, an inner scaling mandrel 1920, an upper scaling head 1925, a lower scaling head 1930, an outer scaling mandrel 1935, a load mandrel 1940, an expansion cone 1945, a mandrel launcher 1950, a

C

mechanical slip body 1955, mechanical slips 1960, drag blocks 1965, casing 1970, and fluid passages 1975, 1980, 1985, and 1990.

The drillpipe 1905 is coupled to the innerstring adapter 1910. During operation of the apparatus 1900, the drillpipe 1905 supports the apparatus 1900. The drillpipe 1905 preferably comprises a substantially hollow tubular member or members. The drillpipe 1905 may be fabricated from any number of conventional commercially available materials such as, for example, oilfield country tubular drillpipe, fiberglass or coiled tubing. The drillpipe 1905 is fabricated from coiled tubing in order to facilitate the placement of the apparatus 1900 in non-vertical wellbores. The drillpipe 1905 may be coupled to the innerstring adapter 1910 using any number of conventional commercially available mechanical couplings such as, for example, drillpipe connectors, OCTG specialty type box and pin connectors, a ratchet-latch type connector or a standard box by pin connector. The drillpipe 1905 is removably coupled to the innerstring adapter 1910 by a drillpipe connection.

The drillpipe 1905 preferably includes a fluid passage 1975 that is adapted to convey fluidic materials from a surface location into the fluid passage 1980. The fluid passage 1975 is adapted to convey fluidic materials such as, for example, cement, drilling mud, epoxy or lubricants at operating pressures and flow rates ranging from about 0 to 9,000 psi and 0 to 3,000 gallons/minute.

The innerstring adapter 1910 is coupled to the drill string 1905 and the sealing sleeve 1915. The innerstring adapter 1910 preferably comprises a substantially hollow tubular member or members. The innerstring adapter 1910 may be fabricated from any number of conventional commercially available materials such as, for example, oil country tubular goods, low alloy steel, carbon steel, stainless steel or other high strength materials. The innerstring adapter 1910 is fabricated from oilfield country tubular goods in order to optimally provide mechanical properties that closely match those of the drill string 1905.

The innerstring adapter 1910 may be coupled to the drill string 1905 using any number of conventional commercially available mechanical couplings such as, for example, drillpipe connectors, oilfield country tubular goods specialty type threaded connectors, ratchet-latch type stab in connector, or a standard threaded connection. The innerstring adapter 1910 is removably coupled to the drill pipe 1905 by a drillpipe

connection. The innerstring adapter 1910 may be coupled to the sealing sleeve 1915 using any number of conventional commercially available mechanical couplings such as, for example, drillpipe connection, oilfield country tubular goods specialty type threaded connector, ratchet-latch type stab in connectors, or a standard threaded connection. The innerstring adapter 1910 is removably coupled to the sealing sleeve 1915 by a standard threaded connection.

The innerstring adapter 1910 preferably includes a fluid passage 1980 that is adapted to convey fluidic materials from the fluid passage 1975 into the fluid passage 1985. The fluid passage 1980 is adapted to convey fluidic materials such as, for example, cement, drilling mud, epoxy, or lubricants at operating pressures and flow rates ranging from about 0 to 9,000 psi and 0 to 3,000 gallons/minute.

The sealing sleeve 1915 is coupled to the innerstring adapter 1910 and the inner sealing mandrel 1920. The sealing sleeve 1915 preferably comprises a substantially hollow tubular member or members. The sealing sleeve 1915 may be fabricated from any number of conventional commercially available materials such as, for example, oilfield country tubular goods, carbon steel, low alloy steel, stainless steel or other high strength materials. The sealing sleeve 1915 is fabricated from oilfield country tubular goods in order to optimally provide mechanical properties that substantially match the remaining components of the apparatus 1900.

The sealing sleeve 1915 may be coupled to the innerstring adapter 1910 using any number of conventional commercially available mechanical couplings such as, for example, drillpipe connection, oilfield country tubular goods specialty type threaded connection, ratchet-latch type stab in connection, or a standard threaded connection. The sealing sleeve 1915 is removably coupled to the innerstring adapter 1910 by a standard threaded connection. The sealing sleeve 1915 may be coupled to the inner sealing mandrel 1920 using any number of conventional commercially available mechanical couplings such as, for example, drillpipe connection, oilfield country tubular goods specialty type threaded connection, or a standard threaded connection. The sealing sleeve 1915 is removably coupled to the inner sealing mandrel 1920 by a standard threaded connection.

The sealing sleeve 1915 preferably includes a fluid passage 1985 that is adapted to convey fluidic materials from the fluid passage 1980 into the fluid passage 1990.

The fluid passage 1985 is adapted to convey fluidic materials such as, for example, cement, drilling mud, epoxy or lubricants at operating pressures and flow rates ranging from about 0 to 9,000 psi and 0 to 3,000 gallons/minute.

5 The inner sealing mandrel 1920 is coupled to the sealing sleeve 1915 and the lower sealing head 1930. The inner sealing mandrel 1920 preferably comprises a substantially hollow tubular member or members. The inner sealing mandrel 1920 may be fabricated from any number of conventional commercially available materials such as, for example, oilfield country tubular goods, stainless steel, low alloy steel, carbon steel or other similar high strength materials. The inner sealing mandrel 1920 is fabricated from stainless steel in order to optimally provide mechanical properties similar to the other components of the apparatus 1900 while also providing a smooth outer surface to support seals and other moving parts that can operate with minimal wear, corrosion and pitting.

15 The inner sealing mandrel 1920 may be coupled to the sealing sleeve 1915 using any number of conventional commercially available mechanical couplings such as, for example, drillpipe connection, oilfield country tubular goods specialty type threaded connection, or a standard threaded connection. The inner sealing mandrel 1920 is removably coupled to the sealing sleeve 1915 by a standard threaded connections. The inner sealing mandrel 1920 may be coupled to the lower sealing head 1930 using any number of conventional commercially available mechanical couplings such as, for example, drillpipe connection, oilfield country tubular goods specialty type threaded connection, ratchet-latch type stab in connectors or standard threaded connections. The inner sealing mandrel 1920 is removably coupled to the lower sealing head 1930 by a standard threaded connections connection.

25 The inner sealing mandrel 1920 preferably includes a fluid passage 1990 that is adapted to convey fluidic materials from the fluid passage 1985 into the fluid passage 1995. The fluid passage 1990 is adapted to convey fluidic materials such as, for example, cement, drilling mud, epoxy or lubricants at operating pressures and flow rates ranging from about 0 to 9,000 psi and 0 to 3,000 gallons/minute.

30 The upper sealing head 1925 is coupled to the outer sealing mandrel 1935 and the expansion cone 1945. The upper sealing head 1925 is also movably coupled to the outer surface of the inner sealing mandrel 1920 and the inner surface of the casing

1970. In this manner, the upper sealing head 1925, outer sealing mandrel 1935, and the expansion cone 1945 reciprocate in the axial direction. The radial clearance between the inner cylindrical surface of the upper sealing head 1925 and the outer surface of the inner sealing mandrel 1920 may range, for example, from about 0.025 to 0.05 inches. The radial clearance between the inner cylindrical surface of the upper sealing head 1925 and the outer surface of the inner sealing mandrel 1920 ranges from about 0.005 to 0.01 inches in order to optimally provide clearance for pressure seal placement. The radial clearance between the outer cylindrical surface of the upper sealing head 1925 and the inner surface of the casing 1970 may range, for example, from about 0.025 to 0.375 inches. The radial clearance between the outer cylindrical surface of the upper sealing head 1925 and the inner surface of the casing 1970 ranges from about 0.025 to 0.125 inches in order to optimally provide stabilization for the expansion cone 1945 as the expansion cone 1945 is upwardly moved inside the casing 1970.

The upper sealing head 1925 preferably comprises an annular member having substantially cylindrical inner and outer surfaces. The upper sealing head 1925 may be fabricated from any number of conventional commercially available materials such as, for example, oilfield country tubular goods, stainless steel, machine tool steel, or similar high strength materials. The upper sealing head 1925 is fabricated from stainless steel in order to optimally provide high strength and smooth outer surfaces that are resistant to wear, galling, corrosion and pitting.

The inner surface of the upper sealing head 1925 preferably includes one or more annular sealing members 2000 for sealing the interface between the upper sealing head 1925 and the inner sealing mandrel 1920. The sealing members 2000 may comprise any number of conventional commercially available annular sealing members such as, for example, o-rings, polypak seals or metal spring energized seals. The sealing members 2000 comprise polypak seals available from Parker Seals in order to optimally provide sealing for a long axial motion.

The upper sealing head 1925 includes a shoulder 2005 for supporting the upper sealing head 1925 on the lower sealing head 1930.

The upper sealing head 1925 may be coupled to the outer sealing mandrel 1935 using any number of conventional commercially available mechanical couplings such

as, for example, drillpipe connection, oilfield country tubular goods specialty type threaded connection, or a standard threaded connections. The upper sealing head 1925 is removably coupled to the outer sealing mandrel 1935 by a standard threaded connections. The mechanical coupling between the upper sealing head 1925 and the  
5 outer sealing mandrel 1935 includes one or more sealing members 2010 for fluidically sealing the interface between the upper sealing head 1925 and the outer sealing mandrel 1935. The sealing members 2010 may comprise any number of conventional commercially available sealing members such as, for example, o-rings, polypak seals or metal spring energized seals. The sealing members 2010 comprise polypak seals  
10 available from Parker Seals in order to optimally provide sealing for a long axial stroking motion.

The lower sealing head 1930 is coupled to the inner sealing mandrel 1920 and the load mandrel 1940. The lower sealing head 1930 is also movably coupled to the inner surface of the outer sealing mandrel 1935. In this manner, the upper sealing head  
15 1925 and outer sealing mandrel 1935 reciprocate in the axial direction. The radial clearance between the outer surface of the lower sealing head 1930 and the inner surface of the outer sealing mandrel 1935 may range, for example, from about 0.025 to 0.05 inches. The radial clearance between the outer surface of the lower sealing head 1930 and the inner surface of the outer sealing mandrel 1935 ranges from about 0.005  
20 to 0.010 inches in order to optimally provide a close tolerance having room for the installation of pressure seal rings.

The lower sealing head 1930 preferably comprises an annular member having substantially cylindrical inner and outer surfaces. The lower sealing head 1930 may be fabricated from any number of conventional commercially available materials such as,  
25 for example, oilfield country tubular goods, stainless steel, machine tool steel or other similar high strength materials. The lower sealing head 1930 is fabricated from stainless steel in order to optimally provide high strength and resistance to wear, galling, corrosion, and pitting.

The outer surface of the lower sealing head 1930 preferably includes one or  
30 more annular sealing members 2015 for sealing the interface between the lower sealing head 1930 and the outer sealing mandrel 1935. The sealing members 2015 may comprise any number of conventional commercially available annular sealing

members such as, for example, o-rings, polypak seals, or metal spring energized seals. The sealing members 2015 comprise polypak seals available from Parker Seals in order to optimally provide sealing for a long axial stroke.

5 The lower sealing head 1930 may be coupled to the inner sealing mandrel 1920 using any number of conventional commercially available mechanical couplings such as, for example, drillpipe connection, oilfield country tubular goods specialty type threaded connection, welding, amorphous bonding or a standard threaded connection. The lower sealing head 1930 is removably coupled to the inner sealing mandrel 1920 by a standard threaded connection.

10 The mechanical coupling between the lower sealing head 1930 and the inner sealing mandrel 1920 includes one or more sealing members 2020 for fluidicly sealing the interface between the lower sealing head 1930 and the inner sealing mandrel 1920. The sealing members 2020 may comprise any number of conventional commercially available sealing members such as, for example, o-rings, polypak seals, or metal spring energized seals. The sealing members 2020 comprise polypak seals available from  
15 Parker Seals in order to optimally provide sealing for a long axial motion.

The lower sealing head 1930 may be coupled to the load mandrel 1940 using any number of conventional commercially available mechanical couplings such as, for example, drillpipe connection, oilfield country tubular goods specialty type threaded  
20 connections, welding, amorphous bonding or a standard threaded connection. The lower sealing head 1930 is removably coupled to the load mandrel 1940 by a standard threaded connection. The mechanical coupling between the lower sealing head 1930 and the load mandrel 1940 includes one or more sealing members 2025 for fluidicly sealing the interface between the lower sealing head 1930 and the load mandrel 1940.  
25 The sealing members 2025 may comprise any number of conventional commercially available sealing members such as, for example, o-rings, polypak seals, or metal spring energized seals. The sealing members 2025 comprise polypak seals available from Parker Seals in order to optimally provide sealing for a long axial stroke.

The lower sealing head 1930 includes a throat passage 2040 fluidicly coupled  
30 between the fluid passages 1990 and 1995. The throat passage 2040 is preferably of reduced size and is adapted to receive and engage with a plug 2045, or other similar

device. In this manner, the fluid passage 1990 is fluidically isolated from the fluid passage 1995. In this manner, the pressure chamber 2030 is pressurized.

The outer sealing mandrel 1935 is coupled to the upper sealing head 1925 and the expansion cone 1945. The outer sealing mandrel 1935 is also movably coupled to the inner surface of the casing 1970 and the outer surface of the lower sealing head 1930. In this manner, the upper sealing head 1925, outer sealing mandrel 1935, and the expansion cone 1945 reciprocate in the axial direction. The radial clearance between the outer surface of the outer sealing mandrel 1935 and the inner surface of the casing 1970 may range, for example, from about 0.025 to 0.375 inches. The radial clearance between the outer surface of the outer sealing mandrel 1935 and the inner surface of the casing 1970 ranges from about 0.025 to 0.125 inches in order to optimally provide maximum piston surface area to maximize the radial expansion force. The radial clearance between the inner surface of the outer sealing mandrel 1935 and the outer surface of the lower sealing head 1930 may range, for example, from about 0.025 to 0.05 inches. The radial clearance between the inner surface of the outer sealing mandrel 1935 and the outer surface of the lower sealing head 1930 ranges from about 0.005 to 0.010 inches in order to optimally provide a minimum gap for the sealing elements to bridge and seal.

The outer sealing mandrel 1935 preferably comprises an annular member having substantially cylindrical inner and outer surfaces. The outer sealing mandrel 1935 may be fabricated from any number of conventional commercially available materials such as, for example, low alloy steel, carbon steel, 13 chromium steel or stainless steel. The outer sealing mandrel 1935 is fabricated from stainless steel in order to optimally provide maximum strength and minimum wall thickness while also providing resistance to corrosion, galling and pitting.

The outer sealing mandrel 1935 may be coupled to the upper sealing head 1925 using any number of conventional commercially available mechanical couplings such as, for example, drillpipe connection, oilfield country tubular goods specialty type threaded connection, standard threaded connections, or welding. The outer sealing mandrel 1935 is removably coupled to the upper sealing head 1925 by a standard threaded connections connection. The outer sealing mandrel 1935 may be coupled to the expansion cone 1945 using any number of conventional commercially available



mechanical couplings such as, for example, drillpipe connection, oilfield country tubular goods specialty type threaded connection, or a standard threaded connections connection, or welding. The outer sealing mandrel 1935 is removably coupled to the expansion cone 1945 by a standard threaded connections connection.

5           The upper sealing head 1925, the lower sealing head 1930, the inner sealing mandrel 1920, and the outer sealing mandrel 1935 together define a pressure chamber 2030. The pressure chamber 2030 is fluidicly coupled to the passage 1990 via one or more passages 2035. During operation of the apparatus 1900, the plug 2045 engages with the throat passage 2040 to fluidicly isolate the fluid passage 1990 from the fluid  
10 passage 1995. The pressure chamber 2030 is then pressurized which in turn causes the upper sealing head 1925, outer sealing mandrel 1935, and expansion cone 1945 to reciprocate in the axial direction. The axial motion of the expansion cone 1945 in turn expands the casing 1970 in the radial direction.

          The load mandrel 1940 is coupled to the lower sealing head 1930 and the  
15 mechanical slip body 1955. The load mandrel 1940 preferably comprises an annular member having substantially cylindrical inner and outer surfaces. The load mandrel 1940 may be fabricated from any number of conventional commercially available materials such as, for example, oilfield country tubular goods, low alloy steel, carbon steel, stainless steel or other similar high strength materials. The load mandrel 1940 is  
20 fabricated from oilfield country tubular goods in order to optimally provide high strength.

          The load mandrel 1940 may be coupled to the lower sealing head 1930 using any number of conventional commercially available mechanical couplings such as, for example, drillpipe connection, oilfield country tubular goods specialty type threaded  
25 connection, welding, amorphous bonding or a standard threaded connection. The load mandrel 1940 is removably coupled to the lower sealing head 1930 by a standard threaded connection. The load mandrel 1940 may be coupled to the mechanical slip body 1955 using any number of conventional commercially available mechanical couplings such as, for example, a drillpipe connection, oilfield country tubular goods  
30 specialty type threaded connections, welding, amorphous bonding, or a standard threaded connections connection. The load mandrel 1940 is removably coupled to the mechanical slip body 1955 by a standard threaded connections connection.

5 The load mandrel 1940 preferably includes a fluid passage 1995 that is adapted to convey fluidic materials from the fluid passage 1990 to the region outside of the apparatus 1900. The fluid passage 1995 is adapted to convey fluidic materials such as, for example, cement, epoxy, water, drilling mud, or lubricants at operating pressures and flow rates ranging from about 0 to 9,000 psi and 0 to 3,000 gallons/minute.

10 The expansion cone 1945 is coupled to the outer scaling mandrel 1935. The expansion cone 1945 is also movably coupled to the inner surface of the casing 1970. In this manner, the upper sealing head 1925, outer scaling mandrel 1935, and the expansion cone 1945 reciprocate in the axial direction. The reciprocation of the expansion cone 1945 causes the casing 1970 to expand in the radial direction.

15 The expansion cone 1945 preferably comprises an annular member having substantially cylindrical inner and conical outer surfaces. The outside radius of the outside conical surface may range, for example, from about 2 to 34 inches. The outside radius of the outside conical surface ranges from about 3 to 28 inches in order to optimally provide cone dimensions for the typical range of tubular members.

20 The axial length of the expansion cone 1945 may range, for example, from about 2 to 8 times the largest outer diameter of the expansion cone 1945. The axial length of the expansion cone 1945 ranges from about 3 to 5 times the largest outer diameter of the expansion cone 1945 in order to optimally provide stability and centralization of the expansion cone 1945 during the expansion process. The angle of attack of the expansion cone 1945 ranges from about 5 to 30 degrees in order to optimally balance friction forces with the desired amount of radial expansion. The expansion cone 1945 angle of attack will vary as a function of the operating parameters of the particular expansion operation.

25 The expansion cone 1945 may be fabricated from any number of conventional commercially available materials such as, for example, machine tool steel, ceramics, tungsten carbide, nitride steel, or other similar high strength materials. The expansion cone 1945 is fabricated from D2 machine tool steel in order to optimally provide high strength and resistance to corrosion, wear, galling, and pitting. The outside surface of the expansion cone 1945 has a surface hardness ranging from about 58 to 62 Rockwell C in order to optimally provide high strength and resist wear and galling.

The expansion cone 1945 may be coupled to the outside sealing mandrel 1935 using any number of conventional commercially available mechanical couplings such as, for example, drillpipe connection, oilfield tubular country goods specialty type threaded connection, welding, amorphous bonding, or a standard threaded connections connection. The expansion cone 1945 is coupled to the outside sealing mandrel 1935 using a standard threaded connections connection in order to optimally provide connector strength for the typical operating loading conditions while also permitting easy replacement of the expansion cone 1945.

The mandrel launcher 1950 is coupled to the casing 1970. The mandrel launcher 1950 comprises a tubular section of casing having a reduced wall thickness compared to the casing 1970. The wall thickness of the mandrel launcher is about 50 to 100 % of the wall thickness of the casing 1970. In this manner, the initiation of the radial expansion of the casing 1970 is facilitated, and the insertion of the larger outside diameter mandrel launcher 1950 into the wellbore and/or casing is facilitated.

The mandrel launcher 1950 may be coupled to the casing 1970 using any number of conventional mechanical couplings. The mandrel launcher 1950 may have a wall thickness ranging, for example, from about 0.15 to 1.5 inches. The wall thickness of the mandrel launcher 1950 ranges from about 0.25 to 0.75 inches in order to optimally provide high strength with a small overall profile. The mandrel launcher 1950 may be fabricated from any number of conventional commercially available materials such as, for example, oil field tubular goods, low alloy steel, carbon steel, stainless steel or other similar high strength materials. The mandrel launcher 1950 is fabricated from oil field tubular goods of higher strength but lower wall thickness than the casing 1970 in order to optimally provide a thin walled container with approximately the same burst strength as the casing 1970.

The mechanical slip body 1955 is coupled to the load mandrel 1970, the mechanical slips 1960, and the drag blocks 1965. The mechanical slip body 1955 preferably comprises a tubular member having an inner passage 2050 fluidically coupled to the passage 1995. In this manner, fluidic materials may be conveyed from the passage 2050 to a region outside of the apparatus 1900.

The mechanical slip body 1955 may be coupled to the load mandrel 1940 using any number of conventional mechanical couplings. The mechanical slip body 1955 is

removably coupled to the load mandrel 1940 using a standard threaded connection in order to optimally provide high strength and permit the mechanical slip body 1955 to be easily replaced. The mechanical slip body 1955 may be coupled to the mechanical slips 1955 using any number of conventional mechanical couplings. The mechanical slip body 1955 is removably coupled to the mechanical slips 1955 using threads and sliding steel retainer rings in order to optimally provide high strength coupling and also permit easy replacement of the mechanical slips 1955. The mechanical slip body 1955 may be coupled to the drag blocks 1965 using any number of conventional mechanical couplings. The mechanical slip body 1955 is removably coupled to the drag blocks 1965 using threaded connections and sliding steel retainer rings in order to optimally provide high strength and also permit easy replacement of the drag blocks 1965.

The mechanical slips 1960 are coupled to the outside surface of the mechanical slip body 1955. During operation of the apparatus 1900, the mechanical slips 1960 prevent upward movement of the casing 1970 and mandrel launcher 1950. In this manner, during the axial reciprocation of the expansion cone 1945, the casing 1970 and mandrel launcher 1950 are maintained in a substantially stationary position. In this manner, the mandrel launcher 1950 and casing 1970 are expanded in the radial direction by the axial movement of the expansion cone 1945.

The mechanical slips 1960 may comprise any number of conventional commercially available mechanical slips such as, for example, RTTS packer tungsten carbide mechanical slips, RTTS packer wicker type mechanical slips or Model 3L retrievable bridge plug tungsten carbide upper mechanical slips. The mechanical slips 1960 comprise RTTS packer tungsten carbide mechanical slips available from Halliburton Energy Services in order to optimally provide resistance to axial movement of the casing 1970 during the expansion process.

The drag blocks 1965 are coupled to the outside surface of the mechanical slip body 1955. During operation of the apparatus 1900, the drag blocks 1965 prevent upward movement of the casing 1970 and mandrel launcher 1950. In this manner, during the axial reciprocation of the expansion cone 1945, the casing 1970 and mandrel launcher 1950 are maintained in a substantially stationary position. In this manner, the mandrel launcher 1950 and casing 1970 are expanded in the radial direction by the axial movement of the expansion cone 1945.

The drag blocks 1965 may comprise any number of conventional commercially available mechanical slips such as, for example, RTTS packer tungsten carbide mechanical slips, RTTS packer wicker type mechanical slips or Model 3L retrievable bridge plug tungsten carbide upper mechanical slips. The drag blocks 1965 comprise  
5 RTTS packer tungsten carbide mechanical slips available from Halliburton Energy Services in order to optimally provide resistance to axial movement of the casing 1970 during the expansion process.

The casing 1970 is coupled to the mandrel launcher 1950. The casing 1970 is further removably coupled to the mechanical slips 1960 and drag blocks 1965. The  
10 casing 1970 preferably comprises a tubular member. The casing 1970 may be fabricated from any number of conventional commercially available materials such as, for example, slotted tubulars, oil field country tubular goods, low alloy steel, carbon steel, stainless steel or other similar high strength materials. The casing 1970 is  
15 fabricated from oilfield country tubular goods available from various foreign and domestic steel mills in order to optimally provide high strength. The upper end of the casing 1970 includes one or more sealing members positioned about the exterior of the casing 1970.

During operation, the apparatus 1900 is positioned in a wellbore with the upper end of the casing 1970 positioned in an overlapping relationship within an existing  
20 wellbore casing. In order minimize surge pressures within the borehole during placement of the apparatus 1900, the fluid passage 1975 is preferably provided with one or more pressure relief passages. During the placement of the apparatus 1900 in the wellbore, the casing 1970 is supported by the expansion cone 1945.

After positioning of the apparatus 1900 within the bore hole in an overlapping  
25 relationship with an existing section of wellbore casing, a first fluidic material is pumped into the fluid passage 1975 from a surface location. The first fluidic material is conveyed from the fluid passage 1975 to the fluid passages 1980, 1985, 1990, 1995, and 2050. The first fluidic material will then exit the apparatus and fill the annular region between the outside of the apparatus 1900 and the interior walls of the bore  
30 hole.

The first fluidic material may comprise any number of conventional commercially available materials such as, for example, drilling mud, water, epoxy or

cement. The first fluidic material comprises a hardenable fluidic sealing material such as, for example, cement or epoxy. In this manner, a wellbore casing having an outer annular layer of a hardenable material may be formed.

5 The first fluidic material may be pumped into the apparatus 1900 at operating pressures and flow rates ranging, for example, from about 0 to 4,500 psi, and 0 to 3,000 gallons/minute. The first fluidic material is pumped into the apparatus 1900 at operating pressures and flow rates ranging from about 0 to 4,500 psi and 0 to 3,000 gallons/minute in order to optimally provide operating pressures and flow rates for typical operating conditions.

10 At a predetermined point in the injection of the first fluidic material such as, for example, after the annular region outside of the apparatus 1900 has been filled to a predetermined level, a plug 2045, dart, or other similar device is introduced into the first fluidic material. The plug 2045 lodges in the throat passage 2040 thereby fluidically isolating the fluid passage 1990 from the fluid passage 1995.

15 After placement of the plug 2045 in the throat passage 2040, a second fluidic material is pumped into the fluid passage 1975 in order to pressurize the pressure chamber 2030. The second fluidic material may comprise any number of conventional commercially available materials such as, for example, water, drilling gases, drilling mud or lubricant. The second fluidic material comprises a non-hardenable fluidic material such as, for example, water, drilling mud or lubricant in order minimize  
20 frictional forces.

The second fluidic material may be pumped into the apparatus 1900 at operating pressures and flow rates ranging, for example, from about 0 to 4,500 psi and 0 to 4,500 gallons/minute. The second fluidic material is pumped into the apparatus  
25 1900 at operating pressures and flow rates ranging from about 0 to 3,500 psi, and 0 to 1,200 gallons/minute in order to optimally provide expansion of the casing 1970.

The pressurization of the pressure chamber 2030 causes the upper sealing head 1925, outer sealing mandrel 1935, and expansion cone 1945 to move in an axial direction. As the expansion cone 1945 moves in the axial direction, the expansion  
30 cone 1945 pulls the mandrel launcher 1950 and drag blocks 1965 along, which sets the mechanical slips 1960 and stops further axial movement of the mandrel launcher 1950

and casing 1970. In this manner, the axial movement of the expansion cone 1945 radially expands the mandrel launcher 1950 and casing 1970.

Once the upper sealing head 1925, outer sealing mandrel 1935, and expansion cone 1945 complete an axial stroke, the operating pressure of the second fluidic material is reduced and the drill string 1905 is raised. This causes the inner sealing mandrel 1920, lower sealing head 1930, load mandrel 1940, and mechanical slip body 1955 to move upward. This unsets the mechanical slips 1960 and permits the mechanical slips 1960 and drag blocks 1965 to be moved upward within the mandrel launcher and casing 1970. When the lower sealing head 1930 contacts the upper sealing head 1925, the second fluidic material is again pressurized and the radial expansion process continues. In this manner, the mandrel launcher 1950 and casing 1970 are radial expanded through repeated axial strokes of the upper sealing head 1925, outer sealing mandrel 1935 and expansion cone 1945. Throughout the radial expansion process, the upper end of the casing 1970 is preferably maintained in an overlapping relation with an existing section of wellbore casing.

At the end of the radial expansion process, the upper end of the casing 1970 is expanded into intimate contact with the inside surface of the lower end of the existing wellbore casing. The sealing members provided at the upper end of the casing 1970 provide a fluidic seal between the outside surface of the upper end of the casing 1970 and the inside surface of the lower end of the existing wellbore casing. The contact pressure between the casing 1970 and the existing section of wellbore casing ranges from about 400 to 10,000 psi in order to optimally provide contact pressure for activating sealing members, provide optimal resistance to axial movement of the expanded casing 1970, and optimally support typical tensile and compressive loads.

As the expansion cone 1945 nears the end of the casing 1970, the operating flow rate of the second fluidic material is reduced in order to minimize shock to the apparatus 1900. In an alternative embodiment, the apparatus 1900 includes a shock absorber for absorbing the shock created by the completion of the radial expansion of the casing 1970.

The reduced operating pressure of the second fluidic material ranges from about 100 to 1,000 psi as the expansion cone 1945 nears the end of the casing 1970 in order to optimally provide reduced axial movement and velocity of the expansion cone 1945.

The operating pressure of the second fluidic material is reduced during the return stroke of the apparatus 1900 to the range of about 0 to 500 psi in order minimize the resistance to the movement of the expansion cone 1945. The stroke length of the apparatus 1900 ranges from about 10 to 45 feet in order to optimally provide  
5 equipment lengths that can be handled by typical oil well rigging equipment while also minimizing the frequency at which the expansion cone 1945 must be stopped so the apparatus 1900 can be re-stroked for further expansion operations.

In an alternative embodiment, at least a portion of the upper sealing head 1925 includes an expansion cone for radially expanding the mandrel launcher 1950 and  
10 casing 1970 during operation of the apparatus 1900 in order to increase the surface area of the casing 1970 acted upon during the radial expansion process. In this manner, the operating pressures can be reduced.

In an alternative embodiment, mechanical slips are positioned in an axial location between the sealing sleeve 1915 and the inner sealing mandrel 1920 in order  
15 to simplify the operation and assembly of the apparatus 1900.

Upon the complete radial expansion of the casing 1970, if applicable, the first fluidic material is permitted to cure within the annular region between the outside of the expanded casing 1970 and the interior walls of the wellbore. In the case where the expanded casing 1970 is slotted, the cured fluidic material will preferably permeate  
20 and envelop the expanded casing. In this manner, a new section of wellbore casing is formed within a wellbore. Alternatively, the apparatus 1900 may be used to join a first section of pipeline to an existing section of pipeline. Alternatively, the apparatus 1900 may be used to directly line the interior of a wellbore with a casing, without the use of an outer annular layer of a hardenable material. Alternatively, the apparatus 1900 may  
25 be used to expand a tubular support member in a hole.

During the radial expansion process, the pressurized areas of the apparatus 1900 are limited to the fluid passages 1975, 1980, 1985, and 1990, and the pressure chamber 2030. No fluid pressure acts directly on the mandrel launcher 1950 and casing 1970. This permits the use of operating pressures higher than the mandrel  
30 launcher 1950 and casing 1970 could normally withstand.

Referring now to Figure 16, an apparatus 2100 for forming a mono-diameter wellbore casing will be described. The apparatus 2100 preferably includes a drillpipe



2105, an innerstring adapter 2110, a sealing sleeve 2115, an inner sealing mandrel 2120, slips 2125, upper sealing head 2130, lower sealing head 2135, outer scaling mandrel 2140, load mandrel 2145, expansion cone 2150, and casing 2155.

5 The drillpipe 2105 is coupled to the innerstring adapter 2110. During operation of the apparatus 2100, the drillpipe 2105 supports the apparatus 2100. The drillpipe 2105 preferably comprises a substantially hollow tubular member or members. The drillpipe 2105 may be fabricated from any number of conventional commercially available materials such as, for example, oilfield country tubular goods, low alloy steel, carbon steel, stainless steel or other similar high strength material. The drillpipe 10 2105 is fabricated from coiled tubing in order to facilitate the placement of the apparatus 1900 in non-vertical wellbores. The drillpipe 2105 may be coupled to the innerstring adapter 2110 using any number of conventional commercially available mechanical couplings such as, for example, drillpipe connection, oilfield country tubular goods specialty type threaded connection, ratchet-latch type connection, or a standard threaded connection. The drillpipe 2105 is removably coupled to the 15 innerstring adapter 2110 by a drill pipe connection.

The drillpipe 2105 preferably includes a fluid passage 2160 that is adapted to convey fluidic materials from a surface location into the fluid passage 2165. The fluid passage 2160 is adapted to convey fluidic materials such as, for example, cement, 20 epoxy, water, drilling mud or lubricants at operating pressures and flow rates ranging from about 0 to 9,000 psi and 0 to 3,000 gallons/minute.

The innerstring adapter 2110 is coupled to the drill string 2105 and the sealing sleeve 2115. The innerstring adapter 2110 preferably comprises a substantially hollow tubular member or members. The innerstring adapter 2110 may be fabricated from 25 any number of conventional commercially available materials such as, for example, oilfield country tubular goods, low alloy steel, carbon steel, stainless steel or other similar high strength materials. The innerstring adapter 2110 is fabricated from stainless steel in order to optimally provide high strength, low friction, and resistance to corrosion and wear.

30 The innerstring adapter 2110 may be coupled to the drill string 2105 using any number of conventional commercially available mechanical couplings such as, for example, drillpipe connection, oilfield country tubular goods specialty type threaded

connection, ratchet-latch type connection or a standard threaded connection. The innerstring adapter 2110 is removably coupled to the drill pipe 2105 by a drillpipe connection. The innerstring adapter 2110 may be coupled to the sealing sleeve 2115 using any number of conventional commercially available mechanical couplings such as, for example, drillpipe connection, oilfield country tubular goods specialty type threaded connection, ratchet-latch type threaded connection, or a standard threaded connection. The innerstring adapter 2110 is removably coupled to the sealing sleeve 2115 by a standard threaded connection.

The innerstring adapter 2110 preferably includes a fluid passage 2165 that is adapted to convey fluidic materials from the fluid passage 2160 into the fluid passage 2170. The fluid passage 2165 is adapted to convey fluidic materials such as, for example, cement, epoxy, water drilling muds, or lubricants at operating pressures and flow rates ranging from about 0 to 9,000 psi and 0 to 3,000 gallons/minute.

The sealing sleeve 2115 is coupled to the innerstring adapter 2110 and the inner sealing mandrel 2120. The sealing sleeve 2115 preferably comprises a substantially hollow tubular member or members. The sealing sleeve 2115 may be fabricated from any number of conventional commercially available materials such as, for example, oil field tubular goods, low alloy steel, carbon steel, stainless steel or other similar high strength materials. The sealing sleeve 2115 is fabricated from stainless steel in order to optimally provide high strength, low friction surfaces, and resistance to corrosion, wear, galling, and pitting.

The sealing sleeve 2115 may be coupled to the innerstring adapter 2110 using any number of conventional commercially available mechanical couplings such as, for example, a standard threaded connection, oilfield country tubular goods specialty type threaded connections, welding, amorphous bonding, or a standard threaded connection.

The sealing sleeve 2115 is removably coupled to the innerstring adapter 2110 by a standard threaded connection. The sealing sleeve 2115 may be coupled to the inner sealing mandrel 2120 using any number of conventional commercially available mechanical couplings such as, for example, a standard threaded connection, oilfield country tubular goods specialty type threaded connections, welding, amorphous bonding, or a standard threaded connection. The sealing sleeve 2115 is removably coupled to the inner sealing mandrel 2120 by a standard threaded connection.

The scaling sleeve 2115 preferably includes a fluid passage 2170 that is adapted to convey fluidic materials from the fluid passage 2165 into the fluid passage 2175. The fluid passage 2170 is adapted to convey fluidic materials such as, for example, cement, epoxy, water, drilling mud, or lubricants at operating pressures and flow rates ranging from about 0 to 9,000 psi and 0 to 3,000 gallons/minute.

The inner sealing mandrel 2120 is coupled to the scaling sleeve 2115, slips 2125, and the lower sealing head 2135. The inner sealing mandrel 2120 preferably comprises a substantially hollow tubular member or members. The inner sealing mandrel 2120 may be fabricated from any number of conventional commercially available materials such as, for example, oilfield country tubular goods, low alloy steel, carbon steel, stainless steel or other similar high strength materials. The inner sealing mandrel 2120 is fabricated from stainless steel in order to optimally provide high strength, low friction surfaces, and corrosion and wear resistance.

The inner sealing mandrel 2120 may be coupled to the scaling sleeve 2115 using any number of conventional commercially available mechanical couplings such as, for example, drillpipe connection, oilfield country tubular goods specialty type threaded connection, or a standard threaded connection. The inner sealing mandrel 2120 is removably coupled to the scaling sleeve 2115 by a standard threaded connection. The standard threaded connection provides high strength and permits easy replacement of components. The inner sealing mandrel 2120 may be coupled to the slips 2125 using any number of conventional commercially available mechanical couplings such as, for example, welding, amorphous bonding, or a standard threaded connection. The inner sealing mandrel 2120 is removably coupled to the slips 2125 by a standard threaded connection. The inner sealing mandrel 2120 may be coupled to the lower sealing head 2135 using any number of conventional commercially available mechanical couplings such as, for example, drillpipe connection, oilfield country tubular goods specialty type threaded connection, welding, amorphous bonding or a standard threaded connection. The inner sealing mandrel 2120 is removably coupled to the lower sealing head 2135 by a standard threaded connection.

The inner sealing mandrel 2120 preferably includes a fluid passage 2175 that is adapted to convey fluidic materials from the fluid passage 2170 into the fluid passage 2180. The fluid passage 2175 is adapted to convey fluidic materials such as, for

.....

example, cement, epoxy, water, drilling mud or lubricants at operating pressures and flow rates ranging from about 0 to 9,000 psi and 0 to 3,000 gallons/minute.

5 The slips 2125 are coupled to the outer surface of the inner sealing mandrel 2120. During operation of the apparatus 2100, the slips 2125 preferably maintain the casing 2155 in a substantially stationary position during the radial expansion of the casing 2155. The slips 2125 are activated using the fluid passages 2185 to convey pressurized fluid material into the slips 2125.

10 The slips 2125 may comprise any number of commercially available hydraulic slips such as, for example, RTTS packer tungsten carbide hydraulic slips or Model 31 retrievable bridge plug hydraulic slips. The slips 2125 comprise RTTS packer tungsten carbide hydraulic slips available from Halliburton Energy Services in order to optimally provide resistance to axial movement of the casing 2155 during the expansion process. The slips include a fluid passage 2190, pressure chamber 2195, spring return 2200, and slip member 2205.

15 The slips 2125 may be coupled to the inner sealing mandrel 2120 using any number of conventional mechanical couplings. The slips 2125 are removably coupled to the outer surface of the inner sealing mandrel 2120 by a thread connection in order to optimally provide interchangeability of parts.

20 The upper sealing head 2130 is coupled to the outer sealing mandrel 2140 and expansion cone 2150. The upper sealing head 2130 is also movably coupled to the outer surface of the inner sealing mandrel 2120 and the inner surface of the casing 2155. In this manner, the upper sealing head 2130 reciprocates in the axial direction. The radial clearance between the inner cylindrical surface of the upper sealing head 2130 and the outer surface of the inner sealing mandrel 2120 may range, for example, 25 from about 0.025 to 0.05 inches. The radial clearance between the inner cylindrical surface of the upper sealing head 2130 and the outer surface of the inner sealing mandrel 2120 ranges from about 0.005 to 0.010 inches in order to optimally provide a pressure seal. The radial clearance between the outer cylindrical surface of the upper sealing head 2130 and the inner surface of the casing 2155 may range, for example, 30 from about 0.025 to 0.375 inches. The radial clearance between the outer cylindrical surface of the upper sealing head 2130 and the inner surface of the casing 2155 ranges

from about 0.025 to 0.125 inches in order to optimally provide stabilization for the expansion cone 2150 during axial movement of the expansion cone 2150.

The upper sealing head 2130 preferably comprises an annular member having substantially cylindrical inner and outer surfaces. The upper sealing head 2130 may be fabricated from any number of conventional commercially available materials such as, for example, low alloy steel, carbon steel, stainless steel or other similar high strength materials. The upper sealing head 2130 is fabricated from stainless steel in order to optimally provide high strength, corrosion resistance, and low friction surfaces. The inner surface of the upper sealing head 2130 preferably includes one or more annular sealing members 2210 for sealing the interface between the upper sealing head 2130 and the inner sealing mandrel 2120. The sealing members 2210 may comprise any number of conventional commercially available annular sealing members such as, for example, o-rings, polypak seals, or metal spring energized seals. The sealing members 2210 comprise polypak seals available from Parker Seals in order to optimally provide sealing for a long axial stroke.

The upper sealing head 2130 includes a shoulder 2215 for supporting the upper sealing head 2130 on the lower sealing head 2135.

The upper sealing head 2130 may be coupled to the outer sealing mandrel 2140 using any number of conventional commercially available mechanical couplings such as, for example, drillpipe connection, oilfield country tubular goods specialty threaded connection, welding, amorphous bonding or a standard threaded connection. The upper sealing head 2130 is removably coupled to the outer sealing mandrel 2140 by a standard threaded connection. The mechanical coupling between the upper sealing head 2130 and the outer sealing mandrel 2140 includes one or more sealing members 2220 for fluidically sealing the interface between the upper sealing head 2130 and the outer sealing mandrel 2140. The sealing members 2220 may comprise any number of conventional commercially available sealing members such as, for example, o-rings, polypak seals, or metal spring energized seals. The sealing members 2220 comprise polypak seals available from Parker Seals in order to optimally provide sealing for a long axial stroke.

The lower sealing head 2135 is coupled to the inner sealing mandrel 2120 and the load mandrel 2145. The lower sealing head 2135 is also movably coupled to the

inner surface of the outer sealing mandrel 2140. In this manner, the upper sealing head 2130, outer sealing mandrel 2140, and expansion cone 2150 reciprocate in the axial direction. The radial clearance between the outer surface of the lower sealing head 2135 and the inner surface of the outer sealing mandrel 2140 may range, for example, from about 0.0025 to 0.05 inches. The radial clearance between the outer surface of the lower sealing head 2135 and the inner surface of the outer sealing mandrel 2140 ranges from about 0.0025 to 0.05 inches in order to optimally provide minimal radial clearance.

The lower sealing head 2135 preferably comprises an annular member having substantially cylindrical inner and outer surfaces. The lower sealing head 2135 may be fabricated from any number of conventional commercially available materials such as, for example, oilfield country tubular goods, low alloy steel, carbon steel, stainless steel or other similar high strength materials. The lower sealing head 2135 is fabricated from stainless steel in order to optimally provide high strength, corrosion resistance, and low friction surfaces. The outer surface of the lower sealing head 2135 preferably includes one or more annular sealing members 2225 for sealing the interface between the lower sealing head 2135 and the outer sealing mandrel 2140. The sealing members 2225 may comprise any number of conventional commercially available annular sealing members such as, for example, o-rings, polypak seals or metal spring energized seals. The sealing members 2225 comprise polypak seals available from Parker Seals in order to optimally provide sealing for a long axial stroke.

The lower sealing head 2135 may be coupled to the inner sealing mandrel 2120 using any number of conventional commercially available mechanical couplings such as, for example, drillpipe connection, oilfield country tubular goods specialty type threaded connection, welding, amorphous bonding, or a standard threaded connection. The lower sealing head 2135 is removably coupled to the inner sealing mandrel 2120 by a standard threaded connection. The mechanical coupling between the lower sealing head 2135 and the inner sealing mandrel 2120 includes one or more sealing members 2230 for fluidically sealing the interface between the lower sealing head 2135 and the inner sealing mandrel 2120. The sealing members 2230 may comprise any number of conventional commercially available sealing members such as, for example, o-rings, polypak seals, or metal spring energized seals. The sealing members 2230

comprise polypak seals available from Parker Seals in order to optimally provide sealing for a long axial stroke.

5 The lower sealing head 2135 may be coupled to the load mandrel 2145 using any number of conventional commercially available mechanical couplings such as, for example, drillpipe connection, oilfield country tubular goods specialty threaded connection, welding, amorphous bonding, or a standard threaded connection. The lower sealing head 2135 is removably coupled to the load mandrel 2145 by a standard threaded connection. The mechanical coupling between the lower sealing head 2135 and the load mandrel 2145 includes one or more sealing members 2235 for fluidically  
10 sealing the interface between the lower sealing head 1930 and the load mandrel 2145. The sealing members 2235 may comprise any number of conventional commercially available sealing members such as, for example, o-rings, polypak seals, or metal spring energized seals. The sealing members 2235 comprise polypak seals available from Parker Seals in order to optimally provide sealing for a long axial stroke.

15 The lower sealing head 2135 includes a throat passage 2240 fluidically coupled between the fluid passages 2175 and 2180. The throat passage 2240 is preferably of reduced size and is adapted to receive and engage with a plug 2245, or other similar device. In this manner, the fluid passage 2175 is fluidically isolated from the fluid passage 2180. In this manner, the pressure chamber 2250 is pressurized.

20 The outer sealing mandrel 2140 is coupled to the upper sealing head 2130 and the expansion cone 2150. The outer sealing mandrel 2140 is also movably coupled to the inner surface of the casing 2155 and the outer surface of the lower sealing head 2135. In this manner, the upper sealing head 2130, outer sealing mandrel 2140, and the expansion cone 2150 reciprocate in the axial direction. The radial clearance  
25 between the outer surface of the outer sealing mandrel 2140 and the inner surface of the casing 2155 may range, for example, from about 0.025 to 0.375 inches. The radial clearance between the outer surface of the outer sealing mandrel 2140 and the inner surface of the casing 2155 ranges from about 0.025 to 0.125 inches in order to optimally provide stabilization for the expansion cone 2130 during the expansion  
30 process. The radial clearance between the inner surface of the outer sealing mandrel 2140 and the outer surface of the lower sealing head 2135 may range, for example, from about 0.005 to 0.125 inches. The radial clearance between the inner surface of

the outer sealing mandrel 2140 and the outer surface of the lower sealing head 2135 ranges from about 0.005 to 0.010 inches in order to optimally provide minimal radial clearance.

5 The outer sealing mandrel 2140 preferably comprises an annular member having substantially cylindrical inner and outer surfaces. The outer sealing mandrel 2140 may be fabricated from any number of conventional commercially available materials such as, for example, oilfield country tubular goods, low alloy steel, carbon steel, stainless steel, or other similar high strength materials. The outer sealing mandrel 2140 is fabricated from stainless steel in order to optimally provide high  
10 strength, corrosion resistance, and low friction surfaces.

The outer sealing mandrel 2140 may be coupled to the upper sealing head 2130 using any number of conventional commercially available mechanical couplings such as, for example, drillpipe connection, oilfield country tubular goods specialty threaded connection, welding, amorphous bonding or a standard threaded connection. The outer  
15 sealing mandrel 2140 is removably coupled to the upper sealing head 2130 by a standard threaded connection. The outer sealing mandrel 2140 may be coupled to the expansion cone 2150 using any number of conventional commercially available mechanical couplings such as, for example, drillpipe connection, oilfield country tubular goods specialty threaded connection, welding, amorphous bonding, or a  
20 standard threaded connection. The outer sealing mandrel 2140 is removably coupled to the expansion cone 2150 by a standard threaded connection.

The upper sealing head 2130, the lower sealing head 2135, inner sealing mandrel 2120, and the outer sealing mandrel 2140 together define a pressure chamber 2250. The pressure chamber 2250 is fluidically coupled to the passage 2175 via one or  
25 more passages 2255. During operation of the apparatus 2100, the plug 2245 engages with the throat passage 2240 to fluidically isolate the fluid passage 2175 from the fluid passage 2180. The pressure chamber 2250 is then pressurized which in turn causes the upper sealing head 2130, outer sealing mandrel 2140, and expansion cone 2150 to reciprocate in the axial direction. The axial motion of the expansion cone 2150 in turn  
30 expands the casing 2155 in the radial direction.

The load mandrel 2145 is coupled to the lower sealing head 2135. The load mandrel 2145 preferably comprises an annular member having substantially cylindrical



C

inner and outer surfaces. The load mandrel 2145 may be fabricated from any number of conventional commercially available materials such as, for example, oilfield country tubular goods, low alloy steel, carbon steel, stainless steel or other similar high strength materials. The load mandrel 2145 is fabricated from stainless steel in order to optimally provide high strength, corrosion resistance, and low friction bearing surfaces.

The load mandrel 2145 may be coupled to the lower sealing head 2135 using any number of conventional commercially available mechanical couplings such as, for example, drillpipe connection, oilfield country tubular goods specialty threaded connection, welding, amorphous bonding or a standard threaded connection. The load mandrel 2145 is removably coupled to the lower sealing head 2135 by a standard threaded connection in order to optimally provide high strength and permit easy replacement of the load mandrel 2145.

The load mandrel 2145 preferably includes a fluid passage 2180 that is adapted to convey fluidic materials from the fluid passage 2180 to the region outside of the apparatus 2100. The fluid passage 2180 is adapted to convey fluidic materials such as, for example, cement, epoxy, water, drilling mud, or lubricants at operating pressures and flow rates ranging from about 0 to 9,000 psi and 0 to 3,000 gallons/minute.

The expansion cone 2150 is coupled to the outer sealing mandrel 2140. The expansion cone 2150 is also movably coupled to the inner surface of the casing 2155. In this manner, the upper sealing head 2130, outer sealing mandrel 2140, and the expansion cone 2150 reciprocate in the axial direction. The reciprocation of the expansion cone 2150 causes the casing 2155 to expand in the radial direction.

The expansion cone 2150 preferably comprises an annular member having substantially cylindrical inner and conical outer surfaces. The outside radius of the outside conical surface may range, for example, from about 2 to 34 inches. The outside radius of the outside conical surface ranges from about 3 to 28 inches in order to optimally provide cone dimensions that are optimal for typical casings. The axial length of the expansion cone 2150 may range, for example, from about 2 to 6 times the largest outside diameter of the expansion cone 2150. The axial length of the expansion cone 2150 ranges from about 3 to 5 times the largest outside diameter of the expansion cone 2150 in order to optimally provide stability and centralization of the expansion

cone 2150 during the expansion process. The maximum outside diameter of the expansion cone 2150 is between about 90 to 100 % of the inside diameter of the existing wellbore that the casing 2155 will be joined with. The angle of attack of the expansion cone 2150 ranges from about 5 to 30 degrees in order to optimally balance friction forces and radial expansion forces. The optimal expansion cone 2150 angle of attack will vary as a function of the particular operating conditions of the expansion operation.

The expansion cone 2150 may be fabricated from any number of conventional commercially available materials such as, for example, machine tool steel, nitride steel, titanium, tungsten carbide, ceramics, or other similar high strength materials. The expansion cone 2150 is fabricated from D2 machine tool steel in order to optimally provide high strength and resistance to wear and galling. The outside surface of the expansion cone 2150 has a surface hardness ranging from about 58 to 62 Rockwell C in order to optimally provide resistance to wear.

The expansion cone 2150 may be coupled to the outside scaling mandrel 2140 using any number of conventional commercially available mechanical couplings such as, for example, drillpipe connection, oilfield country tubular goods specialty type threaded connection, welding, amorphous bonding or a standard threaded connection. The expansion cone 2150 is coupled to the outside scaling mandrel 2140 using a standard threaded connection in order to optimally provide high strength and permit the expansion cone 2150 to be easily replaced.

The casing 2155 is removably coupled to the slips 2125 and expansion cone 2150. The casing 2155 preferably comprises a tubular member. The casing 2155 may be fabricated from any number of conventional commercially available materials such as, for example, slotted tubulars, oilfield country tubular goods, low alloy steel, carbon steel, stainless steel or other similar high strength material. The casing 2155 is fabricated from oilfield country tubular goods available from various foreign and domestic steel mills in order to optimally provide high strength.

The upper end 2260 of the casing 2155 includes a thin wall section 2265 and an outer annular scaling member 2270. The wall thickness of the thin wall section 2265 is about 50 to 100 % of the regular wall thickness of the casing 2155. In this manner, the upper end 2260 of the casing 2155 may be easily expanded and deformed into

intimate contact with the lower end of an existing section of wellbore casing. The lower end of the existing section of casing also includes a thin wall section. In this manner, the radial expansion of the thin walled section 2265 of casing 2155 into the thin walled section of the existing wellbore casing results in a wellbore casing having a substantially constant inside diameter.

The annular sealing member 2270 may be fabricated from any number of conventional commercially available sealing materials such as, for example, epoxy, rubber, metal or plastic. The annular sealing member 2270 is fabricated from Stratalock epoxy in order to optimally provide compressibility and resistance to wear. The outside diameter of the annular sealing member 2270 preferably ranges from about 70 to 95 % of the inside diameter of the lower section of the wellbore casing that the casing 2155 is joined to. In this manner, after expansion, the annular sealing member 2270 preferably provides a fluidic seal and also preferably provides sufficient frictional force with the inside surface of the existing section of wellbore casing during the radial expansion of the casing 2155 to support the casing 2155.

The lower end 2275 of the casing 2155 includes a thin wall section 2280 and an outer annular sealing member 2285. The wall thickness of the thin wall section 2280 is about 50 to 100 % of the regular wall thickness of the casing 2155. In this manner, the lower end 2275 of the casing 2155 may be easily expanded and deformed. Furthermore, in this manner, an other section of casing may be easily joined with the lower end 2275 of the casing 2155 using a radial expansion process. The upper end of the other section of casing also includes a thin wall section. In this manner, the radial expansion of the thin walled section of the upper end of the other casing into the thin walled section 2280 of the lower end of the casing 2155 results in a wellbore casing having a substantially constant inside diameter.

The annular sealing member 2285 may be fabricated from any number of conventional commercially available sealing materials such as, for example, epoxy, rubber, metal or plastic. The annular sealing member 2285 is fabricated from Stratalock epoxy in order to optimally provide compressibility and wear resistance. The outside diameter of the annular sealing member 2285 preferably ranges from about 70 to 95 % of the inside diameter of the lower section of the existing wellbore casing that the casing 2155 is joined to. In this manner, the annular sealing member

2285 preferably provides a fluidic seal and also preferably provides sufficient frictional force with the inside wall of the wellbore during the radial expansion of the casing 2155 to support the casing 2155.

During operation, the apparatus 2100 is preferably positioned in a wellbore with the upper end 2260 of the casing 2155 positioned in an overlapping relationship with the lower end of an existing wellbore casing. The thin wall section 2265 of the casing 2155 is positioned in opposing overlapping relation with the thin wall section and outer annular scaling member of the lower end of the existing section of wellbore casing. In this manner, the radial expansion of the casing 2155 will compress the thin wall sections and annular compressible members of the upper end 2260 of the casing 2155 and the lower end of the existing wellbore casing into intimate contact. During the positioning of the apparatus 2100 in the wellbore, the casing 2155 is supported by the expansion cone 2150.

After positioning of the apparatus 2100, a first fluidic material is then pumped into the fluid passage 2160. The first fluidic material may comprise any number of conventional commercially available materials such as, for example, drilling mud, water, epoxy, or cement. The first fluidic material comprises a hardenable fluidic sealing material such as, for example, cement or epoxy in order to provide a hardenable outer annular body around the expanded casing 2155.

The first fluidic material may be pumped into the fluid passage 2160 at operating pressures and flow rates ranging, for example, from about 0 to 4,500 psi and 0 to 3,000 gallons/minute. The first fluidic material is pumped into the fluid passage 2160 at operating pressures and flow rates ranging from about 0 to 3,500 psi and 0 to 1,200 gallons/minute in order to optimally provide operational efficiency.

The first fluidic material pumped into the fluid passage 2160 passes through the fluid passages 2165, 2170, 2175, 2180 and then outside of the apparatus 2100. The first fluidic material then fills the annular region between the outside of the apparatus 2100 and the interior walls of the wellbore.

The plug 2245 is then introduced into the fluid passage 2160. The plug 2245 lodges in the throat passage 2240 and fluidically isolates and blocks off the fluid passage 2175. A couple of volumes of a non-hardenable fluidic material are then pumped into

the fluid passage 2160 in order to remove any hardenable fluidic material contained within and to ensure that none of the fluid passages are blocked.

5 A second fluidic material is then pumped into the fluid passage 2160. The second fluidic material may comprise any number of conventional commercially available materials such as, for example, drilling mud, water, drilling gases, or lubricants. The second fluidic material comprises a non-hardenable fluidic material such as, for example, water, drilling mud or lubricant in order to optimally provide pressurization of the pressure chamber 2250 and minimize frictional forces.

10 The second fluidic material may be pumped into the fluid passage 2160 at operating pressures and flow rates ranging, for example, from about 0 to 4,500 psi and 0 to 4,500 gallons/minute. The second fluidic material is pumped into the fluid passage 2160 at operating pressures and flow rates ranging from about 0 to 3,500 psi and 0 to 1,200 gallons/minute in order to optimally provide operational efficiency.

15 The second fluidic material pumped into the fluid passage 2160 passes through the fluid passages 2165, 2170, and 2175 into the pressure chambers 2195 of the slips 2125, and into the pressure chamber 2250. Continued pumping of the second fluidic material pressurizes the pressure chambers 2195 and 2250.

20 The pressurization of the pressure chambers 2195 causes the slip members 2205 to expand in the radial direction and grip the interior surface of the casing 2155. The casing 2155 is then preferably maintained in a substantially stationary position.

The pressurization of the pressure chamber 2250 causes the upper sealing head 2130, outer sealing mandrel 2140 and expansion cone 2150 to move in an axial direction relative to the casing 2155. In this manner, the expansion cone 2150 will cause the casing 2155 to expand in the radial direction.

25 During the radial expansion process, the casing 2155 is prevented from moving in an upward direction by the slips 2125. A length of the casing 2155 is then expanded in the radial direction through the pressurization of the pressure chamber 2250. The length of the casing 2155 that is expanded during the expansion process will be proportional to the stroke length of the upper sealing head 2130, outer sealing mandrel  
30 2140, and expansion cone 2150.

Upon the completion of a stroke, the operating pressure of the second fluidic material is reduced and the upper sealing head 2130, outer sealing mandrel 2140, and

expansion cone 2150 drop to their rest positions with the casing 2155 supported by the expansion cone 2150. The position of the drillpipe 2105 is preferably adjusted throughout the radial expansion process in order to maintain the overlapping relationship between the thin walled sections of the lower end of the existing wellbore casing and the upper end of the casing 2155. The stroking of the expansion cone 2150 is then repeated, as necessary, until the thin walled section 2265 of the upper end 2260 of the casing 2155 is expanded into the thin walled section of the lower end of the existing wellbore casing. In this manner, a wellbore casing is formed including two adjacent sections of casing having a substantially constant inside diameter. This process may then be repeated for the entirety of the wellbore to provide a wellbore casing thousands of feet in length having a substantially constant inside diameter.

During the final stroke of the expansion cone 2150, the slips 2125 are positioned as close as possible to the thin walled section 2265 of the upper end of the casing 2155 in order minimize slippage between the casing 2155 and the existing wellbore casing at the end of the radial expansion process. Alternatively, or in addition, the outside diameter of the annular sealing member 2270 is selected to ensure sufficient interference fit with the inside diameter of the lower end of the existing casing to prevent axial displacement of the casing 2155 during the final stroke. Alternatively, or in addition, the outside diameter of the annular sealing member 2285 is selected to provide an interference fit with the inside walls of the wellbore at an earlier point in the radial expansion process so as to prevent further axial displacement of the casing 2155. In this final alternative, the interference fit is preferably selected to permit expansion of the casing 2155 by pulling the expansion cone 2150 out of the wellbore, without having to pressurize the pressure chamber 2250.

During the radial expansion process, the pressurized areas of the apparatus 2100 are limited to the fluid passages 2160, 2165, 2170, and 2175, the pressure chambers 2195 within the slips 2125, and the pressure chamber 2250. No fluid pressure acts directly on the casing 2155. This permits the use of operating pressures higher than the casing 2155 could normally withstand.

Once the casing 2155 has been completely expanded off of the expansion cone 2150, remaining portions of the apparatus 2100 are removed from the wellbore. The contact pressure between the deformed thin wall sections and compressible annular

C

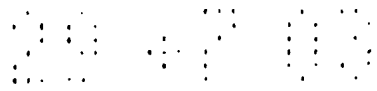

members of the lower end of the existing casing and the upper end 2260 of the casing 2155 ranges from about 500 to 40,000 psi in order to optimally support the casing 2155 using the existing wellbore casing.

5 In this manner, the casing 2155 is radially expanded into contact with an existing section of casing by pressurizing the interior fluid passages 2160, 2165, 2170, and 2175 and the pressure chamber 2250 of the apparatus 2100.

As required, the annular body of hardenable fluidic material is then allowed to cure to form a rigid outer annular body about the expanded casing 2155. In the case where the casing 2155 is slotted, the cured fluidic material preferably permeates and envelops the expanded casing 2155. The resulting new section of wellbore casing 10 includes the expanded casing 2155 and the rigid outer annular body. The overlapping joint between the pre-existing wellbore casing and the expanded casing 2155 includes the deformed thin wall sections and the compressible outer annular bodies. The inner diameter of the resulting combined wellbore casings is substantially constant. In this 15 manner, a mono-diameter wellbore casing is formed. This process of expanding overlapping tubular members having thin wall end portions with compressible annular bodies into contact can be repeated for the entire length of a wellbore. In this manner, a mono-diameter wellbore casing can be provided for thousands of feet in a subterranean formation.

20 As the expansion cone 2150 nears the upper end of the casing 2155, the operating flow rate of the second fluidic material is reduced in order to minimize shock to the apparatus 2100. In an alternative embodiment, the apparatus 2100 includes a shock absorber for absorbing the shock created by the completion of the radial expansion of the casing 2155.

25 The reduced operating pressure of the second fluidic material ranges from about 100 to 1,000 psi as the expansion cone 2130 nears the end of the casing 2155 in order to optimally provide reduced axial movement and velocity of the expansion cone 2130. The operating pressure of the second fluidic material is reduced during the return stroke of the apparatus 2100 to the range of about 0 to 500 psi in order minimize the 30 resistance to the movement of the expansion cone 2130 during the return stroke. The stroke length of the apparatus 2100 ranges from about 10 to 45 feet in order to optimally provide equipment lengths that can be handled by conventional oil well

C

rigging equipment while also minimizing the frequency at which the expansion cone 2130 must be stopped so that the apparatus 2100 can be re-stroked.

In an alternative embodiment, at least a portion of the upper sealing head 2130 includes an expansion cone for radially expanding the casing 2155 during operation of the apparatus 2100 in order to increase the surface area of the casing 2155 acted upon during the radial expansion process. In this manner, the operating pressures can be reduced.

Alternatively, the apparatus 2100 may be used to join a first section of pipeline to an existing section of pipeline. Alternatively, the apparatus 2100 may be used to directly line the interior of a wellbore with a casing, without the use of an outer annular layer of a hardenable material. Alternatively, the apparatus 2100 may be used to expand a tubular support member in a hole.

Referring now to Figures 17, 17a and 17b, another embodiment of an apparatus 2300 for expanding a tubular member will be described. The apparatus 2300 preferably includes a drillpipe 2305, an innerstring adapter 2310, a sealing sleeve 2315, a hydraulic slip body 2320, hydraulic slips 2325, an inner sealing mandrel 2330, an upper sealing head 2335, a lower sealing head 2340, a load mandrel 2345, an outer sealing mandrel 2350, an expansion cone 2355, a mechanical slip body 2360, mechanical slips 2365, drag blocks 2370, casing 2375, fluid passages 2380, 2385, 2390, 2395, 2400, 2405, 2410, 2415, and 2485, and mandrel launcher 2480.

The drillpipe 2305 is coupled to the innerstring adapter 2310. During operation of the apparatus 2300, the drillpipe 2305 supports the apparatus 2300. The drillpipe 2305 preferably comprises a substantially hollow tubular member or members. The drillpipe 2305 may be fabricated from any number of conventional commercially available materials such as, for example, oilfield country tubular goods, low alloy steel, carbon steel, stainless steel or other similar high strength materials. The drillpipe 2305 is fabricated from coiled tubing in order to facilitate the placement of the apparatus 2300 in non-vertical wellbores. The drillpipe 2305 may be coupled to the innerstring adapter 2310 using any number of conventional commercially available mechanical couplings such as, for example, drillpipe connection, oilfield country tubular goods specialty threaded connection, or a standard threaded connection. The



drillpipe 2305 is removably coupled to the innerstring adapter 2310 by a drillpipe connection.

The drillpipe 2305 preferably includes a fluid passage 2380 that is adapted to convey fluidic materials from a surface location into the fluid passage 2385. The fluid passage 2380 is adapted to convey fluidic materials such as, for example, cement, water, epoxy, drilling muds, or lubricants at operating pressures and flow rates ranging from about 0 to 9,000 psi and 0 to 5,000 gallons/minute in order to optimally provide operational efficiency.

The innerstring adapter 2310 is coupled to the drill string 2305 and the sealing sleeve 2315. The innerstring adapter 2310 preferably comprises a substantially hollow tubular member or members. The innerstring adapter 2310 may be fabricated from any number of conventional commercially available materials such as, for example, oilfield country tubular goods, low alloy steel, carbon steel, stainless steel or other similar high strength materials. The innerstring adapter 2310 is fabricated from stainless steel in order to optimally provide high strength, corrosion resistance, and low friction surfaces.

The innerstring adapter 2310 may be coupled to the drill string 2305 using any number of conventional commercially available mechanical couplings such as, for example, drillpipe connection, oilfield country tubular goods specialty threaded connection, or a standard threaded connection. The innerstring adapter 2310 is removably coupled to the drill pipe 2305 by a drillpipe connection. The innerstring adapter 2310 may be coupled to the sealing sleeve 2315 using any number of conventional commercially available mechanical couplings such as, for example, a drillpipe connection, oilfield country tubular goods specialty threaded connection, or a standard threaded connection. The innerstring adapter 2310 is removably coupled to the sealing sleeve 2315 by a standard threaded connection.

The innerstring adapter 2310 preferably includes a fluid passage 2385 that is adapted to convey fluidic materials from the fluid passage 2380 into the fluid passage 2390. The fluid passage 2385 is adapted to convey fluidic materials such as, for example, cement, epoxy, water, drilling mud, drilling gases or lubricants at operating pressures and flow rates ranging from about 0 to 9,000 psi and 0 to 3,000 gallons/minute.

C

5 The sealing sleeve 2315 is coupled to the innerstring adapter 2310 and the hydraulic slip body 2320. The sealing sleeve 2315 preferably comprises a substantially hollow tubular member or members. The sealing sleeve 2315 may be fabricated from any number of conventional commercially available materials such as, for example, oilfield country tubular goods, low alloy steel, carbon steel, stainless steel or other similar high strength materials. The sealing sleeve 2315 is fabricated from stainless steel in order to optimally provide high strength, corrosion resistance, and low-friction surfaces.

10 The sealing sleeve 2315 may be coupled to the innerstring adapter 2310 using any number of conventional commercially available mechanical couplings such as, for example, drillpipe connections, oilfield country tubular goods specialty threaded connections, or a standard threaded connection. The sealing sleeve 2315 is removably coupled to the innerstring adapter 2310 by a standard threaded connection. The sealing sleeve 2315 may be coupled to the hydraulic slip body 2320 using any number  
15 of conventional commercially available mechanical couplings such as, for example, drillpipe connection, oilfield country tubular goods specialty threaded connection, or a standard threaded connection. The sealing sleeve 2315 is removably coupled to the hydraulic slip body 2320 by a standard threaded connection.

20 The sealing sleeve 2315 preferably includes a fluid passage 2390 that is adapted to convey fluidic materials from the fluid passage 2385 into the fluid passage 2395. The fluid passage 2315 is adapted to convey fluidic materials such as, for example, cement, epoxy, water, drilling mud or lubricants at operating pressures and flow rates ranging from about 0 to 9,000 psi and 0 to 3,000 gallons/minute.

25 The hydraulic slip body 2320 is coupled to the sealing sleeve 2315, the hydraulic slips 2325, and the inner sealing mandrel 2330. The hydraulic slip body 2320 preferably comprises a substantially hollow tubular member or members. The hydraulic slip body 2320 may be fabricated from any number of conventional commercially available materials such as, for example, oilfield country tubular goods, low alloy steel, carbon steel, stainless steel or other high strength material. The  
30 hydraulic slip body 2320 is fabricated from carbon steel in order to optimally provide high strength at low cost.

The hydraulic slip body 2320 may be coupled to the sealing sleeve 2315 using any number of conventional commercially available mechanical couplings such as, for example, drillpipe connection, oilfield country tubular goods specialty threaded connection, or a standard threaded connection. The hydraulic slip body 2320 is  
5 removably coupled to the scaling sleeve 2315 by a standard threaded connection. The hydraulic slip body 2320 may be coupled to the slips 2325 using any number of conventional commercially available mechanical couplings such as, for example, drillpipe connection, oilfield country tubular goods specialty threaded connection, welding, amorphous bonding or a standard threaded connection. The hydraulic slip  
10 body 2320 is removably coupled to the slips 2325 by a standard threaded connection. The hydraulic slip body 2320 may be coupled to the inner scaling mandrel 2330 using any number of conventional commercially available mechanical couplings such as, for example, drillpipe connection, oilfield country tubular goods specialty threaded connection, welding, amorphous bonding or a standard threaded connection. The  
15 hydraulic slip body 2320 is removably coupled to the inner scaling mandrel 2330 by a standard threaded connection.

The hydraulic slips body 2320 preferably includes a fluid passage 2395 that is adapted to convey fluidic materials from the fluid passage 2390 into the fluid passage 2405. The fluid passage 2395 is adapted to convey fluidic materials such as, for  
20 example, cement, epoxy, water, drilling mud or lubricants at operating pressures and flow rates ranging from about 0 to 9,000 psi and 0 to 3,000 gallons/minute.

The hydraulic slips body 2320 preferably includes fluid passage 2400 that are adapted to convey fluidic materials from the fluid passage 2395 into the pressure chambers 2420 of the hydraulic slips 2325. In this manner, the slips 2325 are activated  
25 upon the pressurization of the fluid passage 2395 into contact with the inside surface of the casing 2375. The fluid passages 2400 are adapted to convey fluidic materials such as, for example, water, drilling mud or lubricants at operating pressures and flow rates ranging from about 0 to 9,000 psi and 0 to 3,000 gallons/minute.

The slips 2325 are coupled to the outside surface of the hydraulic slip body  
30 2320. During operation of the apparatus 2300, the slips 2325 are activated upon the pressurization of the fluid passage 2395 into contact with the inside surface of the

casing 2375. In this manner, the slips 2325 maintain the casing 2375 in a substantially stationary position.

5 The slips 2325 preferably include the fluid passages 2400, the pressure chambers 2420, spring bias 2425, and slip members 2430. The slips 2325 may comprise any number of conventional commercially available hydraulic slips such as, for example, RTTS packer tungsten carbide hydraulic slips or Model 3L retrievable bridge plug with hydraulic slips. The slips 2325 comprise RTTS packer tungsten carbide hydraulic slips available from Halliburton Energy Services in order to optimally provide resistance to axial movement of the casing 2375 during the radial expansion process.

10 The inner sealing mandrel 2330 is coupled to the hydraulic slip body 2320 and the lower sealing head 2340. The inner sealing mandrel 2330 preferably comprises a substantially hollow tubular member or members. The inner sealing mandrel 2330 may be fabricated from any number of conventional commercially available materials such as, for example, oilfield country tubular goods, low alloy steel, carbon steel, stainless steel or other similar high strength materials. The inner sealing mandrel 2330 is fabricated from stainless steel in order to optimally provide high strength, corrosion resistance, and low friction surfaces.

20 The inner sealing mandrel 2330 may be coupled to the hydraulic slip body 2320 using any number of conventional commercially available mechanical couplings such as, for example, drillpipe connection, oilfield country tubular goods specialty threaded connection, welding, amorphous bonding, or a standard threaded connection. The inner sealing mandrel 2330 is removably coupled to the hydraulic slip body 2320 by a standard threaded connection. The inner sealing mandrel 2330 may be coupled to the lower sealing head 2340 using any number of conventional commercially available mechanical couplings such as, for example, drillpipe connection, oilfield country tubular goods specialty threaded connection, welding, amorphous bonding, or a standard threaded connection. The inner sealing mandrel 2330 is removably coupled to the lower sealing head 2340 by a standard threaded connection.

30 The inner sealing mandrel 2330 preferably includes a fluid passage 2405 that is adapted to convey fluidic materials from the fluid passage 2395 into the fluid passage 2415. The fluid passage 2405 is adapted to convey fluidic materials such as, for

example, cement, epoxy, water, drilling mud, or lubricants at operating pressures and flow rates ranging from about 0 to 9,000 psi and 0 to 3,000 gallons/minute.

The upper sealing head 2335 is coupled to the outer sealing mandrel 2345 and expansion cone 2355. The upper sealing head 2335 is also movably coupled to the  
5 outer surface of the inner sealing mandrel 2330 and the inner surface of the casing 2375. In this manner, the upper sealing head 2335 reciprocates in the axial direction. The radial clearance between the inner cylindrical surface of the upper sealing head 2335 and the outer surface of the inner sealing mandrel 2330 may range, for example, from about 0.0025 to 0.05 inches. The radial clearance between the inner cylindrical  
10 surface of the upper sealing head 2335 and the outer surface of the inner sealing mandrel 2330 ranges from about 0.005 to 0.01 inches in order to optimally provide minimal clearance. The radial clearance between the outer cylindrical surface of the upper sealing head 2335 and the inner surface of the casing 2375 may range, for example, from about 0.025 to 0.375 inches. The radial clearance between the outer  
15 cylindrical surface of the upper sealing head 2335 and the inner surface of the casing 2375 ranges from about 0.025 to 0.125 inches in order to optimally provide stabilization for the expansion cone 2355 during the expansion process.

The upper sealing head 2335 preferably comprises an annular member having substantially cylindrical inner and outer surfaces. The upper sealing head 2335 may be  
20 fabricated from any number of conventional commercially available materials such as, for example, oilfield country tubular goods, low alloy steel, carbon steel, stainless steel or other similar high strength materials. The upper sealing head 2335 is fabricated from stainless steel in order to optimally provide high strength, corrosion resistance, and low friction surfaces. The inner surface of the upper sealing head 2335 preferably  
25 includes one or more annular sealing members 2435 for sealing the interface between the upper sealing head 2335 and the inner sealing mandrel 2330. The sealing members 2435 may comprise any number of conventional commercially available annular sealing members such as, for example, o-rings, polypak seals or metal spring energized seals. The sealing members 2435 comprise polypak seals available from Parker Seals  
30 in order to optimally provide sealing for a long axial stroke.

The upper sealing head 2335 includes a shoulder 2440 for supporting the upper sealing head on the lower sealing head 1930.

The upper sealing head 2335 may be coupled to the outer sealing mandrel 2350 using any number of conventional commercially available mechanical couplings such as, for example, drillpipe connection, oilfield country tubular goods specialty threaded connection, welding, amorphous bonding, or a standard threaded connection. The upper sealing head 2335 is removably coupled to the outer sealing mandrel 2350 by a standard threaded connection. The mechanical coupling between the upper sealing head 2335 and the outer sealing mandrel 2350 includes one or more sealing members 2445 for fluidically sealing the interface between the upper sealing head 2335 and the outer sealing mandrel 2350. The sealing members 2445 may comprise any number of conventional commercially available sealing members such as, for example, o-rings, polypak seals or metal spring energized seals. The sealing members 2445 comprise polypak seals available from Parker Seals in order to optimally provide sealing for long axial strokes.

The lower sealing head 2340 is coupled to the inner sealing mandrel 2330 and the load mandrel 2345. The lower sealing head 2340 is also movably coupled to the inner surface of the outer sealing mandrel 2350. In this manner, the upper sealing head 2335 and outer sealing mandrel 2350 reciprocate in the axial direction. The radial clearance between the outer surface of the lower sealing head 2340 and the inner surface of the outer sealing mandrel 2350 may range, for example, from about 0.0025 to 0.05 inches. The radial clearance between the outer surface of the lower sealing head 2340 and the inner surface of the outer sealing mandrel 2350 ranges from about 0.005 to 0.010 inches in order to optimally provide minimal radial clearance.

The lower sealing head 2340 preferably comprises an annular member having substantially cylindrical inner and outer surfaces. The lower sealing head 2340 may be fabricated from any number of conventional commercially available materials such as, for example, oilfield tubular members, low alloy steel, carbon steel, stainless steel or other similar high strength materials. The lower sealing head 2340 is fabricated from stainless steel in order to optimally provide high strength, corrosion resistance, and low friction surfaces. The outer surface of the lower sealing head 2340 preferably includes one or more annular sealing members 2450 for sealing the interface between the lower sealing head 2340 and the outer sealing mandrel 2350. The sealing members 2450 may comprise any number of conventional commercially available annular sealing

members such as, for example, o-rings, polypak seals or metal spring energized seals. The sealing members 2450 comprise polypak seals available from Parker Seals in order to optimally provide sealing for a long axial stroke.

5 The lower sealing head 2340 may be coupled to the inner sealing mandrel 2330 using any number of conventional commercially available mechanical couplings such as, for example, drillpipe connection, oilfield country tubular specialty threaded connection, welding, amorphous bonding, or standard threaded connection. The lower sealing head 2340 is removably coupled to the inner sealing mandrel 2330 by a standard threaded connection. The mechanical coupling between the lower sealing  
10 head 2340 and the inner sealing mandrel 2330 includes one or more sealing members 2455 for fluidically sealing the interface between the lower sealing head 2340 and the inner sealing mandrel 2330. The sealing members 2455 may comprise any number of conventional commercially available sealing members such as, for example, o-rings, polypak or metal spring energized seals. The sealing members 2455 comprise polypak  
15 seals available from Parker Seals in order to optimally provide sealing for a long axial stroke length.

The lower sealing head 2340 may be coupled to the load mandrel 2345 using any number of conventional commercially available mechanical couplings such as, for example, drillpipe connection, oilfield country tubular goods specialty threaded  
20 connection, welding, amorphous bonding or a standard threaded connection. The lower sealing head 2340 is removably coupled to the load mandrel 2345 by a standard threaded connection. The mechanical coupling between the lower sealing head 2340 and the load mandrel 2345 includes one or more sealing members 2460 for fluidically sealing the interface between the lower sealing head 2340 and the load mandrel 2345.  
25 The sealing members 2460 may comprise any number of conventional commercially available sealing members such as, for example, o-rings, polypak seals or metal spring energized seals. The sealing members 2460 comprise polypak seals available from Parker Seals in order to optimally provide sealing for a long axial stroke length.

The lower sealing head 2340 includes a throat passage 2465 fluidically coupled  
30 between the fluid passages 2405 and 2415. The throat passage 2465 is preferably of reduced size and is adapted to receive and engage with a plug 2470, or other similar

device. In this manner, the fluid passage 2405 is fluidically isolated from the fluid passage 2415. In this manner, the pressure chamber 2475 is pressurized.

5 The outer sealing mandrel 2350 is coupled to the upper sealing head 2335 and the expansion cone 2355. The outer sealing mandrel 2350 is also movably coupled to the inner surface of the casing 2375 and the outer surface of the lower sealing head 2340. In this manner, the upper sealing head 2335, outer sealing mandrel 2350, and the expansion cone 2355 reciprocate in the axial direction. The radial clearance between the outer surface of the outer sealing mandrel 2350 and the inner surface of the casing 2375 may range, for example, from about 0.025 to 0.375 inches. The radial clearance between the outer surface of the outer sealing mandrel 2350 and the inner surface of the casing 2375 ranges from about 0.025 to 0.125 inches in order to optimally provide stabilization for the expansion cone 2355 during the expansion process. The radial clearance between the inner surface of the outer sealing mandrel 2350 and the outer surface of the lower sealing head 2340 may range, for example, 15 from about 0.0025 to 0.375 inches. The radial clearance between the inner surface of the outer sealing mandrel 2350 and the outer surface of the lower sealing head 2340 ranges from about 0.005 to 0.010 inches in order to optimally provide minimal clearance.

20 The outer sealing mandrel 2350 preferably comprises an annular member having substantially cylindrical inner and outer surfaces. The outer sealing mandrel 2350 may be fabricated from any number of conventional commercially available materials such as, for example, low alloy steel, carbon steel, stainless steel or other similar high strength materials. The outer sealing mandrel 2350 is fabricated from stainless steel in order to optimally provide high strength, corrosion resistance, and 25 low friction surfaces.

The outer sealing mandrel 2350 may be coupled to the upper sealing head 2335 using any number of conventional commercially available mechanical couplings such as, for example, drillpipe connections, oilfield country tubular goods specialty threaded connections, welding, amorphous bonding, or a standard threaded connection. The 30 outer sealing mandrel 2350 is removably coupled to the upper sealing head 2335 by a standard threaded connection. The outer sealing mandrel 2350 may be coupled to the expansion cone 2355 using any number of conventional commercially available



mechanical couplings such as, for example, drillpipe connection, oilfield country tubular goods specialty threaded connection, welding, amorphous bonding, or a standard threaded connection. The outer sealing mandrel 2350 is removably coupled to the expansion cone 2355 by a standard threaded connection.

5 The upper sealing head 2335, the lower sealing head 2340, the inner sealing mandrel 2330, and the outer sealing mandrel 2350 together define a pressure chamber 2475. The pressure chamber 2475 is fluidically coupled to the passage 2405 via one or more passages 2410. During operation of the apparatus 2300, the plug 2470 engages with the throat passage 2465 to fluidically isolate the fluid passage 2415 from the fluid  
10 passage 2405. The pressure chamber 2475 is then pressurized which in turn causes the upper sealing head 2335, outer sealing mandrel 2350, and expansion cone 2355 to reciprocate in the axial direction. The axial motion of the expansion cone 2355 in turn expands the casing 2375 in the radial direction.

The load mandrel 2345 is coupled to the lower sealing head 2340 and the  
15 mechanical slip body 2360. The load mandrel 2345 preferably comprises an annular member having substantially cylindrical inner and outer surfaces. The load mandrel 2345 may be fabricated from any number of conventional commercially available materials such as, for example, oilfield country tubular goods, low alloy steel, carbon steel, stainless steel or other similar high strength materials. The load mandrel 2345 is  
20 fabricated from stainless steel in order to optimally provide high strength, corrosion resistance, and low friction surfaces.

The load mandrel 2345 may be coupled to the lower sealing head 2340 using any number of conventional commercially available mechanical couplings such as, for example, drillpipe connection, oilfield country tubular goods specialty threaded  
25 connection, welding, amorphous bonding or a standard threaded connection. The load mandrel 2345 is removably coupled to the lower sealing head 2340 by a standard threaded connection. The load mandrel 2345 may be coupled to the mechanical slip body 2360 using any number of conventional commercially available mechanical couplings such as, for example, drillpipe connection, oilfield country tubular goods  
30 specialty threaded connection, welding, amorphous bonding, or a standard threaded connection. The load mandrel 2345 is removably coupled to the mechanical slip body 2360 by a standard threaded connection.

The load mandrel 2345 preferably includes a fluid passage 2415 that is adapted to convey fluidic materials from the fluid passage 2405 to the region outside of the apparatus 2300. The fluid passage 2415 is adapted to convey fluidic materials such as, for example, cement, epoxy, water, drilling mud or lubricants at operating pressures and flow rates ranging from about 0 to 9,000 psi and 0 to 3,000 gallons/minute.

The expansion cone 2355 is coupled to the outer sealing mandrel 2350. The expansion cone 2355 is also movably coupled to the inner surface of the casing 2375. In this manner, the upper scaling head 2335, outer sealing mandrel 2350, and the expansion cone 2355 reciprocate in the axial direction. The reciprocation of the expansion cone 2355 causes the casing 2375 to expand in the radial direction.

The expansion cone 2355 preferably comprises an annular member having substantially cylindrical inner and conical outer surfaces. The outside radius of the outside conical surface may range, for example, from about 2 to 34 inches. The outside radius of the outside conical surface ranges from about 3 to 28 inches in order to optimally provide radial expansion of the typical casings. The axial length of the expansion cone 2355 may range, for example, from about 2 to 8 times the largest outside diameter of the expansion cone 2355. The axial length of the expansion cone 2355 ranges from about 3 to 5 times the largest outside diameter of the expansion cone 2355 in order to optimally provide stability and centralization of the expansion cone 2355 during the expansion process. The angle of attack of the expansion cone 2355 ranges from about 5 to 30 degrees in order to optimally frictional forces with radial expansion forces. The optimum angle of attack of the expansion cone 2355 will vary as a function of the operating parameters of the particular expansion operation.

The expansion cone 2355 may be fabricated from any number of conventional commercially available materials such as, for example, machine tool steel, nitride steel, titanium, tungsten carbide, ceramics or other similar high strength materials. The expansion cone 2355 is fabricated from D2 machine tool steel in order to optimally provide high strength, abrasion resistance, and galling resistance. The outside surface of the expansion cone 2355 has a surface hardness ranging from about 58 to 62 Rockwell C in order to optimally provide high strength, abrasion resistance, resistance to galling.

The expansion cone 2355 may be coupled to the outside scaling mandrel 2350 using any number of conventional commercially available mechanical couplings such as, for example, drillpipe connection, oilfield country tubular goods specialty threaded connection, welding, amorphous bonding, or a standard threaded connection. The expansion cone 2355 is coupled to the outside scaling mandrel 2350 using a standard threaded connection in order to optimally provide high strength and permit the expansion cone 2355 to be easily replaced.

The mandrel launcher 2480 is coupled to the casing 2375. The mandrel launcher 2480 comprises a tubular section of casing having a reduced wall thickness compared to the casing 2375. The wall thickness of the mandrel launcher 2480 is about 50 to 100 % of the wall thickness of the casing 2375. In this manner, the initiation of the radial expansion of the casing 2375 is facilitated, and the placement of the apparatus 2300 into a wellbore casing and wellbore is facilitated.

The mandrel launcher 2480 may be coupled to the casing 2375 using any number of conventional mechanical couplings. The mandrel launcher 2480 may have a wall thickness ranging, for example, from about 0.15 to 1.5 inches. The wall thickness of the mandrel launcher 2480 ranges from about 0.25 to 0.75 inches in order to optimally provide high strength in a minimal profile. The mandrel launcher 2480 may be fabricated from any number of conventional commercially available materials such as, for example, oilfield tubular goods, low alloy steel, carbon steel, stainless steel or other similar high strength materials. The mandrel launcher 2480 is fabricated from oilfield tubular goods having a higher strength than that of the casing 2375 but with a smaller wall thickness than the casing 2375 in order to optimally provide a thin walled container having approximately the same burst strength as that of the casing 2375.

The mechanical slip body 2360 is coupled to the load mandrel 2345, the mechanical slips 2365, and the drag blocks 2370. The mechanical slip body 2360 preferably comprises a tubular member having an inner passage 2485 fluidically coupled to the passage 2415. In this manner, fluidic materials may be conveyed from the passage 2484 to a region outside of the apparatus 2300.

The mechanical slip body 2360 may be coupled to the load mandrel 2345 using any number of conventional mechanical couplings. The mechanical slip body 2360 is removably coupled to the load mandrel 2345 using threads and sliding steel retaining

C

rings in order to optimally provide a high strength attachment. The mechanical slip body 2360 may be coupled to the mechanical slips 2365 using any number of conventional mechanical couplings. The mechanical slip body 2360 is removably coupled to the mechanical slips 2365 using threads and sliding steel retaining rings in order to optimally provide a high strength attachment. The mechanical slip body 2360 may be coupled to the drag blocks 2370 using any number of conventional mechanical couplings. The mechanical slip body 2360 is removably coupled to the drag blocks 2365 using threads and sliding steel retaining rings in order to optimally provide a high strength attachment.

10 The mechanical slips 2365 are coupled to the outside surface of the mechanical slip body 2360. During operation of the apparatus 2300, the mechanical slips 2365 prevent upward movement of the casing 2375 and mandrel launcher 2480. In this manner, during the axial reciprocation of the expansion cone 2355, the casing 2375 and mandrel launcher 2480 are maintained in a substantially stationary position. In 15 this manner, the mandrel launcher 2480 and casing 2375 are expanded in the radial direction by the axial movement of the expansion cone 2355.

The mechanical slips 2365 may comprise any number of conventional commercially available mechanical slips such as, for example, RTTS packer tungsten carbide mechanical slips, RTTS packer wicker type mechanical slips or Model 3L 20 retrievable bridge plug tungsten carbide upper mechanical slips. The mechanical slips 2365 comprise RTTS packer tungsten carbide mechanical slips available from Halliburton Energy Services in order to optimally provide resistance to axial movement of the casing 2375 during the expansion process.

The drag blocks 2370 are coupled to the outside surface of the mechanical slip 25 body 2360. During operation of the apparatus 2300, the drag blocks 2370 prevent upward movement of the casing 2375 and mandrel launcher 2480. In this manner, during the axial reciprocation of the expansion cone 2355, the casing 2375 and mandrel launcher 2480 are maintained in a substantially stationary position. In this manner, the mandrel launcher 2480 and casing 2375 are expanded in the radial 30 direction by the axial movement of the expansion cone 2355.

The drag blocks 2370 may comprise any number of conventional commercially available mechanical slips such as, for example, RTTS packer mechanical drag blocks

or Model 3L retrievable bridge plug drag blocks. The drag blocks 2370 comprise RTTS packer mechanical drag blocks available from Halliburton Energy Services in order to optimally provide resistance to axial movement of the casing 2375 during the expansion process.

5           The casing 2375 is coupled to the mandrel launcher 2480. The casing 2375 is further removably coupled to the mechanical slips 2365 and drag blocks 2370. The casing 2375 preferably comprises a tubular member. The casing 2375 may be fabricated from any number of conventional commercially available materials such as, for example, slotted tubulars, oil country tubular goods, carbon steel, low alloy steel,  
10 stainless steel or other similar high strength materials. The casing 2375 is fabricated from oilfield country tubular goods available from various foreign and domestic steel mills in order to optimally provide high strength. The upper end of the casing 2375 includes one or more sealing members positioned about the exterior of the casing 2375.

15           During operation, the apparatus 2300 is positioned in a wellbore with the upper end of the casing 2375 positioned in an overlapping relationship within an existing wellbore casing. In order minimize surge pressures within the borehole during placement of the apparatus 2300, the fluid passage 2380 is preferably provided with one or more pressure relief passages. During the placement of the apparatus 2300 in  
20 the wellbore, the casing 2375 is supported by the expansion cone 2355.

          After positioning of the apparatus 2300 within the bore hole in an overlapping relationship with an existing section of wellbore casing, a first fluidic material is pumped into the fluid passage 2380 from a surface location. The first fluidic material is conveyed from the fluid passage 2380 to the fluid passages 2385, 2390, 2395, 2405,  
25 2415, and 2485. The first fluidic material will then exit the apparatus 2300 and fill the annular region between the outside of the apparatus 2300 and the interior walls of the bore hole.

          The first fluidic material may comprise any number of conventional commercially available materials such as, for example, epoxy, drilling mud, slag mix,  
30 cement, or water. The first fluidic material comprises a hardenable fluidic sealing material such as, for example, slag mix, epoxy, or cement. In this manner, a wellbore casing having an outer annular layer of a hardenable material may be formed.

The first fluidic material may be pumped into the apparatus 2300 at operating pressures and flow rates ranging, for example, from about 0 to 4,500 psi, and 0 to 3,000 gallons/minute. The first fluidic material is pumped into the apparatus 2300 at operating pressures and flow rates ranging from about 0 to 3,500 psi and 0 to 1,200 gallons/minute in order to optimally provide operational efficiency.

At a predetermined point in the injection of the first fluidic material such as, for example, after the annular region outside of the apparatus 2300 has been filled to a predetermined level, a plug 2470, dart, or other similar device is introduced into the first fluidic material. The plug 2470 lodges in the throat passage 2465 thereby fluidically isolating the fluid passage 2405 from the fluid passage 2415.

After placement of the plug 2470 in the throat passage 2465, a second fluidic material is pumped into the fluid passage 2380 in order to pressurize the pressure chamber 2475. The second fluidic material may comprise any number of conventional commercially available materials such as, for example, water, drilling gases, drilling mud or lubricants. The second fluidic material comprises a non-hardenable fluidic material such as, for example, water, drilling mud or lubricant.

The second fluidic material may be pumped into the apparatus 2300 at operating pressures and flow rates ranging, for example, from about 0 to 4,500 psi and 0 to 4,500 gallons/minute. The second fluidic material is pumped into the apparatus 2300 at operating pressures and flow rates ranging from about 0 to 3,500 psi and 0 to 1,200 gallons/minute in order to optimally provide operational efficiency.

The pressurization of the pressure chamber 2475 causes the upper sealing head 2335, outer sealing mandrel 2350, and expansion cone 2355 to move in an axial direction. The pressurization of the pressure chamber 2475 also causes the hydraulic slips 2325 to expand in the radial direction and hold the casing 2375 in a substantially stationary position. Furthermore, as the expansion cone 2355 moves in the axial direction, the expansion cone 2355 pulls the mandrel launcher 2480 and drag blocks 2370 along, which sets the mechanical slips 2365 and stops further axial movement of the mandrel launcher 2480 and casing 2375. In this manner, the axial movement of the expansion cone 2355 radially expands the mandrel launcher 2480 and casing 2375.

Once the upper sealing head 2335, outer sealing mandrel 2350, and expansion cone 2355 complete an axial stroke, the operating pressure of the second fluidic

material is reduced. The reduction in the operating pressure of the second fluidic material releases the hydraulic slips 2325. The drill string 2305 is then raised. This causes the inner sealing mandrel 2330, lower sealing head 2340, load mandrel 2345, and mechanical slip body 2360 to move upward. This unsets the mechanical slips 2365 and permits the mechanical slips 2365 and drag blocks 2370 to be moved within the mandrel launcher 2480 and casing 2375. When the lower sealing head 2340 contacts the upper sealing head 2335, the second fluidic material is again pressurized and the radial expansion process continues. In this manner, the mandrel launcher 2480 and casing 2375 are radial expanded through repeated axial strokes of the upper sealing head 2335, outer sealing mandrel 2350 and expansion cone 2355. Throughout the radial expansion process, the upper end of the casing 2375 is preferably maintained in an overlapping relation with an existing section of wellbore casing.

At the end of the radial expansion process, the upper end of the casing 2375 is expanded into intimate contact with the inside surface of the lower end of the existing wellbore casing. The sealing members provided at the upper end of the casing 2375 provide a fluidic seal between the outside surface of the upper end of the casing 2375 and the inside surface of the lower end of the existing wellbore casing. The contact pressure between the casing 2375 and the existing section of wellbore casing ranges from about 400 to 10,000 psi in order to optimally provide contact pressure, activate the sealing members, and withstand typical tensile and compressive loading conditions.

As the expansion cone 2355 nears the upper end of the casing 2375, the operating pressure of the second fluidic material is reduced in order to minimize shock to the apparatus 2300. In an alternative embodiment, the apparatus 2300 includes a shock absorber for absorbing the shock created by the completion of the radial expansion of the casing 2375.

The reduced operating pressure of the second fluidic material ranges from about 100 to 1,000 psi as the expansion cone 2355 nears the end of the casing 2375 in order to optimally provide reduced axial movement and velocity of the expansion cone 2355. The operating pressure of the second fluidic material is reduced during the return stroke of the apparatus 2300 to the range of about 0 to 500 psi in order minimize the resistance to the movement of the expansion cone 2355 during the return stroke. The

stroke length of the apparatus 2300 ranges from about 10 to 45 feet in order to optimally provide equipment that can be handled by typical oil well rigging equipment and minimize the frequency at which the expansion cone 2355 must be stopped to permit the apparatus 2300 to be re-stroked.

5 In an alternative embodiment, at least a portion of the upper sealing head 2335 includes an expansion cone for radially expanding the mandrel launcher 2480 and casing 2375 during operation of the apparatus 2300 in order to increase the surface area of the casing 2375 acted upon during the radial expansion process. In this manner, the operating pressures can be reduced.

10 In an alternative embodiment, mechanical slips 2365 are positioned in an axial location between the sealing sleeve 2315 and the inner sealing mandrel 2330 in order to optimally the construction and operation of the apparatus 2300.

Upon the complete radial expansion of the casing 2375, if applicable, the first fluidic material is permitted to cure within the annular region between the outside of the expanded casing 2375 and the interior walls of the wellbore. In the case where the casing 2375 is slotted, the cured fluidic material preferably permeates and envelops the expanded casing 2375. In this manner, a new section of wellbore casing is formed within a wellbore. Alternatively, the apparatus 2300 may be used to join a first section of pipeline to an existing section of pipeline. Alternatively, the apparatus 2300 may be used to directly line the interior of a wellbore with a casing, without the use of an outer annular layer of a hardenable material. Alternatively, the apparatus 2300 may be used to expand a tubular support member in a hole.

During the radial expansion process, the pressurized areas of the apparatus 2300 are limited to the fluid passages 2380, 2385, 2390, 2395, 2400, 2405, and 2410, and the pressure chamber 2475. No fluid pressure acts directly on the mandrel launcher 2480 and casing 2375. This permits the use of operating pressures higher than the mandrel launcher 2480 and casing 2375 could normally withstand.

Referring now to Figure 18, an apparatus 2500 for forming a mono-diameter wellbore casing will be described. The apparatus 2500 preferably includes a drillpipe 2505, an innerstring adapter 2510, a sealing sleeve 2515, a hydraulic slip body 2520, hydraulic slips 2525, an inner sealing mandrel 2530, upper sealing head 2535, lower sealing head 2540, outer sealing mandrel 2545, load mandrel 2550, expansion cone



2555, casing 2560, and fluid passages 2565, 2570, 2575, 2580, 2585, 2590, 2595, and 2600.

The drillpipe 2505 is coupled to the innerstring adapter 2510. During operation of the apparatus 2500, the drillpipe 2505 supports the apparatus 2500. The drillpipe 5 2505 preferably comprises a substantially hollow tubular member or members. The drillpipe 2505 may be fabricated from any number of conventional commercially available materials such as, for example, oilfield country tubular goods, low alloy steel, carbon steel, stainless steel or other similar high strength materials. The drillpipe 2505 is fabricated from coiled tubing in order to facilitate the placement of the 10 apparatus 2500 in non-vertical wellbores. The drillpipe 2505 may be coupled to the innerstring adapter 2510 using any number of conventional commercially available mechanical couplings such as, for example, drillpipe connection, oilfield country tubular goods specialty threaded connection, or a standard threaded connection. The drillpipe 2505 is removably coupled to the innerstring adapter 2510 by a drillpipe 15 connection. a drillpipe connection provides the advantages of high strength and easy disassembly.

The drillpipe 2505 preferably includes a fluid passage 2565 that is adapted to convey fluidic materials from a surface location into the fluid passage 2570. The fluid passage 2565 is adapted to convey fluidic materials such as, for example, cement, 20 epoxy, water, drilling mud, or lubricants at operating pressures and flow rates ranging from about 0 to 9,000 psi and 0 to 3,000 gallons/minute.

The innerstring adapter 2510 is coupled to the drill string 2505 and the sealing sleeve 2515. The innerstring adapter 2510 preferably comprises a substantially hollow tubular member or members. The innerstring adapter 2510 may be fabricated from 25 any number of conventional commercially available materials such as, for example, oilfield country tubular goods, low alloy steel, carbon steel, stainless steel or other similar high strength materials. The innerstring adapter 2510 is fabricated from stainless steel in order to optimally provide high strength, corrosion resistance, and low friction surfaces.

30 The innerstring adapter 2510 may be coupled to the drill string 2505 using any number of conventional commercially available mechanical couplings such as, for example, drillpipe connection, oilfield country tubular goods specialty type threaded

connection, or a standard threaded connection. The innerstring adapter 2510 is removably coupled to the drill pipe 2505 by a drillpipe connection. The innerstring adapter 2510 may be coupled to the sealing sleeve 2515 using any number of conventional commercially available mechanical couplings such as, for example, drillpipe connection, oilfield country tubular goods specialty type threaded connection, ratchet-latch type threaded connection or a standard threaded connection. The innerstring adapter 2510 is removably coupled to the scaling sleeve 2515 by a standard threaded connection.

The innerstring adapter 2510 preferably includes a fluid passage 2570 that is adapted to convey fluidic materials from the fluid passage 2565 into the fluid passage 2575. The fluid passage 2570 is adapted to convey fluidic materials such as, for example, cement, epoxy, water, drilling mud or lubricants at operating pressures and flow rates ranging from about 0 to 9,000 psi and 0 to 3,000 gallons/minute.

The sealing sleeve 2515 is coupled to the innerstring adapter 2510 and the hydraulic slip body 2520. The sealing sleeve 2515 preferably comprises a substantially hollow tubular member or members. The sealing sleeve 2515 may be fabricated from any number of conventional commercially available materials such as, for example, oilfield country tubular goods, low alloy steel, carbon steel, stainless steel or other similar high strength materials. The sealing sleeve 2515 is fabricated from stainless steel in order to optimally provide high strength, corrosion resistance, and low-friction surfaces.

The sealing sleeve 2515 may be coupled to the innerstring adapter 2510 using any number of conventional commercially available mechanical couplings such as, for example, drillpipe connections, oilfield country tubular goods specialty type threaded connection, ratchet-latch type threaded connection, or a standard threaded connection. The sealing sleeve 2515 is removably coupled to the innerstring adapter 2510 by a standard threaded connection. The sealing sleeve 2515 may be coupled to the hydraulic slip body 2520 using any number of conventional commercially available mechanical couplings such as, for example, drillpipe connection, oilfield country tubular goods specialty type threaded connection, ratchet-latch type threaded connection, or a standard threaded connection. The sealing sleeve 2515 is removably coupled to the hydraulic slip body 2520 by a standard threaded connection.

The sealing sleeve 2515 preferably includes a fluid passage 2575 that is adapted to convey fluidic materials from the fluid passage 2570 into the fluid passage 2580. The fluid passage 2575 is adapted to convey fluidic materials such as, for example, cement, epoxy, water, drilling mud or lubricants at operating pressures and flow rates ranging from about 0 to 9,000 psi and 0 to 3,000 gallons/minute.

The hydraulic slip body 2520 is coupled to the sealing sleeve 2515, the hydraulic slips 2525, and the inner sealing mandrel 2530. The hydraulic slip body 2520 preferably comprises a substantially hollow tubular member or members. The hydraulic slip body 2520 may be fabricated from any number of conventional commercially available materials such as, for example, oilfield country tubular goods, low alloy steel, carbon steel, stainless steel or other similar high strength materials. The hydraulic slip body 2520 is fabricated from carbon steel in order to optimally provide high strength.

The hydraulic slip body 2520 may be coupled to the sealing sleeve 2515 using any number of conventional commercially available mechanical couplings such as, for example, drillpipe connection, oilfield country tubular goods specialty type threaded connection, ratchet-latch type threaded connection or a standard threaded connection. The hydraulic slip body 2520 is removably coupled to the sealing sleeve 2515 by a standard threaded connection. The hydraulic slip body 2520 may be coupled to the slips 2525 using any number of conventional commercially available mechanical couplings such as, for example, threaded connection or welding. The hydraulic slip body 2520 is removably coupled to the slips 2525 by a threaded connection. The hydraulic slip body 2520 may be coupled to the inner sealing mandrel 2530 using any number of conventional commercially available mechanical couplings such as, for example, drillpipe connection, oilfield country tubular goods specialty type threaded connection, welding, amorphous bonding or a standard threaded connection. The hydraulic slip body 2520 is removably coupled to the inner sealing mandrel 2530 by a standard threaded connection.

The hydraulic slips body 2520 preferably includes a fluid passage 2580 that is adapted to convey fluidic materials from the fluid passage 2575 into the fluid passage 2590. The fluid passage 2580 is adapted to convey fluidic materials such as, for

example, cement, epoxy, water, drilling mud or lubricants at operating pressures and flow rates ranging from about 0 to 9,000 psi and 0 to 3,000 gallons/minute.

5 The hydraulic slips body 2520 preferably includes fluid passages 2585 that are adapted to convey fluidic materials from the fluid passage 2580 into the pressure chambers of the hydraulic slips 2525. In this manner, the slips 2525 are activated upon the pressurization of the fluid passage 2580 into contact with the inside surface of the casing 2560. The fluid passages 2585 are adapted to convey fluidic materials such as, for example, water, drilling mud or lubricants at operating pressures and flow rates ranging from about 0 to 9,000 psi and 0 to 3,000 gallons/minute.

10 The slips 2525 are coupled to the outside surface of the hydraulic slip body 2520. During operation of the apparatus 2500, the slips 2525 are activated upon the pressurization of the fluid passage 2580 into contact with the inside surface of the casing 2560. In this manner, the slips 2525 maintain the casing 2560 in a substantially stationary position.

15 The slips 2525 preferably include the fluid passages 2585, the pressure chambers 2605, spring bias 2610, and slip members 2615. The slips 2525 may comprise any number of conventional commercially available hydraulic slips such as, for example, RTTS packer tungsten carbide hydraulic slips or Model 3L retrievable bridge plug with hydraulic slips. The slips 2525 comprise RTTS packer tungsten  
20 carbide hydraulic slips available from Halliburton Energy Services in order to optimally provide resistance to axial movement of the casing 2560 during the expansion process.

25 The inner sealing mandrel 2530 is coupled to the hydraulic slip body 2520 and the lower sealing head 2540. The inner sealing mandrel 2530 preferably comprises a substantially hollow tubular member or members. The inner sealing mandrel 2530 may be fabricated from any number of conventional commercially available materials such as, for example, oilfield country tubular goods, low alloy steel, carbon steel, stainless steel or other similar high strength materials. The inner sealing mandrel 2530 is fabricated from stainless steel in order to optimally provide high strength, corrosion  
30 resistance, and low friction surfaces.

The inner sealing mandrel 2530 may be coupled to the hydraulic slip body 2520 using any number of conventional commercially available mechanical couplings such

as, for example, drillpipe connection, oilfield country tubular goods specialty type threaded connection, welding, amorphous bonding, or a standard threaded connection.

The inner sealing mandrel 2530 is removably coupled to the hydraulic slip body 2520 by a standard threaded connection. The inner sealing mandrel 2530 may be coupled  
5 to the lower sealing head 2540 using any number of conventional commercially available mechanical couplings such as, for example, oilfield country tubular goods specialty type threaded connection, drillpipe connection, welding, amorphous bonding, or a standard threaded connection. The inner sealing mandrel 2530 is removably coupled to the lower sealing head 2540 by a standard threaded connection.

10 The inner sealing mandrel 2530 preferably includes a fluid passage 2590 that is adapted to convey fluidic materials from the fluid passage 2580 into the fluid passage 2600. The fluid passage 2590 is adapted to convey fluidic materials such as, for example, cement, epoxy, water, drilling mud or lubricants at operating pressures and flow rates ranging from about 0 to 9,000 psi and 0 to 3,000 gallons/minute.

15 The upper sealing head 2535 is coupled to the outer sealing mandrel 2545 and expansion cone 2555. The upper sealing head 2535 is also movably coupled to the outer surface of the inner sealing mandrel 2530 and the inner surface of the casing 2560. In this manner, the upper sealing head 2535 reciprocates in the axial direction. The radial clearance between the inner cylindrical surface of the upper sealing head  
20 2535 and the outer surface of the inner sealing mandrel 2530 may range, for example, from about 0.0025 to 0.05 inches. The radial clearance between the inner cylindrical surface of the upper sealing head 2535 and the outer surface of the inner sealing mandrel 2530 ranges from about 0.005 to 0.01 inches in order to optimally provide minimal radial clearance. The radial clearance between the outer cylindrical surface of  
25 the upper sealing head 2535 and the inner surface of the casing 2560 may range, for example, from about 0.025 to 0.375 inches. The radial clearance between the outer cylindrical surface of the upper sealing head 2535 and the inner surface of the casing 2560 ranges from about 0.025 to 0.125 inches in order to optimally provide stabilization for the expansion cone 2535 during the expansion process.

30 The upper sealing head 2535 preferably comprises an annular member having substantially cylindrical inner and outer surfaces. The upper sealing head 2535 may be fabricated from any number of conventional commercially available materials such as,

for example, oilfield country tubular goods, low alloy steel, carbon steel, stainless steel or other similar high strength materials. The upper sealing head 2535 is fabricated from stainless steel in order to optimally provide high strength, corrosion resistance, and low friction surfaces. The inner surface of the upper sealing head 2535 preferably includes one or more annular sealing members 2620 for sealing the interface between the upper sealing head 2535 and the inner sealing mandrel 2530. The sealing members 2620 may comprise any number of conventional commercially available annular sealing members such as, for example, o-rings, polypak seals, or metal spring energized seals. The sealing members 2620 comprise polypak seals available from Parker Seals in order to optimally provide sealing for a long axial stroke.

The upper sealing head 2535 includes a shoulder 2625 for supporting the upper sealing head 2535, outer sealing mandrel 2545, and expansion cone 2555 on the lower sealing head 2540.

The upper sealing head 2535 may be coupled to the outer sealing mandrel 2545 using any number of conventional commercially available mechanical couplings such as, for example, oilfield country tubular goods specialty threaded connection, pipeline connection, welding, amorphous bonding, or a standard threaded connection. The upper sealing head 2535 is removably coupled to the outer sealing mandrel 2545 by a standard threaded connection. The mechanical coupling between the upper sealing head 2535 and the outer sealing mandrel 2545 includes one or more sealing members 2630 for fluidically sealing the interface between the upper sealing head 2535 and the outer sealing mandrel 2545. The sealing members 2630 may comprise any number of conventional commercially available sealing members such as, for example, o-rings, polypak seals or metal spring energized seals. The sealing members 2630 comprise polypak seals available from Parker Seals in order to optimally provide sealing for a long axial stroke.

The lower sealing head 2540 is coupled to the inner sealing mandrel 2530 and the load mandrel 2550. The lower sealing head 2540 is also movably coupled to the inner surface of the outer sealing mandrel 2545. In this manner, the upper sealing head 2535, outer sealing mandrel 2545, and expansion cone 2555 reciprocate in the axial direction.

The radial clearance between the outer surface of the lower sealing head 2540 and the inner surface of the outer sealing mandrel 2545 may range, for example, from about 0.0025 to 0.05 inches. The radial clearance between the outer surface of the lower sealing head 2540 and the inner surface of the outer sealing mandrel 2545 ranges from about 0.005 to 0.01 inches in order to optimally provide minimal radial clearance.

The lower sealing head 2540 preferably comprises an annular member having substantially cylindrical inner and outer surfaces. The lower sealing head 2540 may be fabricated from any number of conventional commercially available materials such as, for example, oilfield country tubular goods, low alloy steel, carbon steel, stainless steel or other similar high strength materials. The lower sealing head 2540 is fabricated from stainless steel in order to optimally provide high strength, corrosion resistance, and low friction surfaces. The outer surface of the lower sealing head 2540 preferably includes one or more annular sealing members 2635 for sealing the interface between the lower sealing head 2540 and the outer sealing mandrel 2545. The sealing members 2635 may comprise any number of conventional commercially available annular sealing members such as, for example, o-rings, polypak seals, or metal spring energized seals. The sealing members 2635 comprise polypak seals available from Parker Seals in order to optimally provide sealing for a long axial stroke.

The lower sealing head 2540 may be coupled to the inner sealing mandrel 2530 using any number of conventional commercially available mechanical couplings such as, for example, drillpipe connections, oilfield country tubular goods specialty threaded connection, or a standard threaded connection. The lower sealing head 2540 is removably coupled to the inner sealing mandrel 2530 by a standard threaded connection. The mechanical coupling between the lower sealing head 2540 and the inner sealing mandrel 2530 includes one or more sealing members 2640 for fluidically sealing the interface between the lower sealing head 2540 and the inner sealing mandrel 2530. The sealing members 2640 may comprise any number of conventional commercially available sealing members such as, for example, o-rings, polypak seals or metal spring energized seals. The sealing members 2640 comprise polypak seals available from Parker Seals in order to optimally provide sealing for a long axial stroke.

The lower sealing head 2540 may be coupled to the load mandrel 2550 using any number of conventional commercially available mechanical couplings such as, for example, drillpipe connection, oilfield country tubular goods specialty type threaded connection, welding, amorphous bonding or a standard threaded connection. The lower sealing head 2540 is removably coupled to the load mandrel 2550 by a standard threaded connection. The mechanical coupling between the lower sealing head 2540 and the load mandrel 2550 includes one or more sealing members 2645 for fluidically sealing the interface between the lower sealing head 2540 and the load mandrel 2550. The sealing members 2645 may comprise any number of conventional commercially available sealing members such as, for example, o-rings, polypak seals or metal spring energized seals. The sealing members 2645 comprise polypak seals available from Parker Seals in order to optimally provide sealing for a long axial stroke.

The lower sealing head 2540 includes a throat passage 2650 fluidically coupled between the fluid passages 2590 and 2600. The throat passage 2650 is preferably of reduced size and is adapted to receive and engage with a plug 2655, or other similar device. In this manner, the fluid passage 2590 is fluidically isolated from the fluid passage 2600. In this manner, the pressure chamber 2660 is pressurized.

The outer sealing mandrel 2545 is coupled to the upper sealing head 2535 and the expansion cone 2555. The outer sealing mandrel 2545 is also movably coupled to the inner surface of the casing 2560 and the outer surface of the lower sealing head 2540. In this manner, the upper sealing head 2535, outer sealing mandrel 2545, and the expansion cone 2555 reciprocate in the axial direction. The radial clearance between the outer surface of the outer sealing mandrel 2545 and the inner surface of the casing 2560 may range, for example, from about 0.025 to 0.375 inches. The radial clearance between the outer surface of the outer sealing mandrel 2545 and the inner surface of the casing 2560 ranges from about 0.025 to 0.125 inches in order to optimally provide stabilization for the expansion cone 2535 during the expansion process. The radial clearance between the inner surface of the outer sealing mandrel 2545 and the outer surface of the lower sealing head 2540 may range, for example, from about 0.005 to 0.01 inches. The radial clearance between the inner surface of the outer sealing mandrel 2545 and the outer surface of the lower sealing head 2540 ranges from about 0.005 to 0.01 inches in order to optimally provide minimal radial clearance.



The outer sealing mandrel 2545 preferably comprises an annular member having substantially cylindrical inner and outer surfaces. The outer sealing mandrel 2545 may be fabricated from any number of conventional commercially available materials such as, for example, oilfield country tubular goods, low alloy steel, carbon steel, stainless steel or other similar high strength materials. The outer sealing mandrel 2545 is fabricated from stainless steel in order to optimally provide high strength, corrosion resistance, and low friction surfaces.

The outer sealing mandrel 2545 may be coupled to the upper sealing head 2535 using any number of conventional commercially available mechanical couplings such as, for example, drillpipe connection, oilfield country tubular goods specialty type threaded connection, welding, amorphous bonding, or a standard threaded connection. The outer sealing mandrel 2545 is removably coupled to the upper sealing head 2535 by a standard threaded connection. The outer sealing mandrel 2545 may be coupled to the expansion cone 2555 using any number of conventional commercially available mechanical couplings such as, for example, drillpipe connection, oilfield country tubular goods specialty type threaded connection, welding, amorphous bonding, or a standard threaded connection. The outer sealing mandrel 2545 is removably coupled to the expansion cone 2555 by a standard threaded connection.

The upper sealing head 2535, the lower sealing head 2540, the inner sealing mandrel 2530, and the outer sealing mandrel 2545 together define a pressure chamber 2660. The pressure chamber 2660 is fluidically coupled to the passage 2590 via one or more passages 2595. During operation of the apparatus 2500, the plug 2655 engages with the throat passage 2650 to fluidically isolate the fluid passage 2590 from the fluid passage 2600. The pressure chamber 2660 is then pressurized which in turn causes the upper sealing head 2535, outer sealing mandrel 2545, and expansion cone 2555 to reciprocate in the axial direction. The axial motion of the expansion cone 2555 in turn expands the casing 2560 in the radial direction.

The load mandrel 2550 is coupled to the lower sealing head 2540. The load mandrel 2550 preferably comprises an annular member having substantially cylindrical inner and outer surfaces. The load mandrel 2550 may be fabricated from any number of conventional commercially available materials such as, for example, oilfield country tubular goods, low alloy steel, carbon steel, stainless steel or other similar high

strength materials. The load mandrel 2550 is fabricated from stainless steel in order to optimally provide high strength, corrosion resistance, and low friction surfaces.

5 The load mandrel 2550 may be coupled to the lower sealing head 2540 using any number of conventional commercially available mechanical couplings such as, for example, oilfield country tubular goods, drillpipe connection, welding, amorphous bonding, or a standard threaded connection. The load mandrel 2550 is removably coupled to the lower sealing head 2540 by a standard threaded connection.

10 The load mandrel 2550 preferably includes a fluid passage 2600 that is adapted to convey fluidic materials from the fluid passage 2590 to the region outside of the apparatus 2500. The fluid passage 2600 is adapted to convey fluidic materials such as, for example, cement, epoxy, water, drilling mud, or lubricants at operating pressures and flow rates ranging, for example, from about 0 to 9,000 psi and 0 to 3,000 gallons/minute.

15 The expansion cone 2555 is coupled to the outer sealing mandrel 2545. The expansion cone 2555 is also movably coupled to the inner surface of the casing 2560. In this manner, the upper sealing head 2535, outer sealing mandrel 2545, and the expansion cone 2555 reciprocate in the axial direction. The reciprocation of the expansion cone 2555 causes the casing 2560 to expand in the radial direction.

20 The expansion cone 2555 preferably comprises an annular member having substantially cylindrical inner and conical outer surfaces. The outside radius of the outside conical surface may range, for example, from about 2 to 34 inches. The outside radius of the outside conical surface ranges from about 3 to 28 in order to optimally provide radial expansion for the widest variety of tubular casings. The axial length of the expansion cone 2555 may range, for example, from about 2 to 8 times the largest outside diameter of the expansion cone 2535. The axial length of the expansion cone 2535 ranges from about 3 to 5 times the largest outside diameter of the expansion cone 2535 in order to optimally provide stabilization and centralization of the expansion cone 2535 during the expansion process. The maximum outside diameter of the expansion cone 2555 is between about 95 to 99 % of the inside diameter of the existing wellbore that the casing 2560 will be joined with. The angle of attack of the expansion cone 2555 ranges from about 5 to 30 degrees in order to optimally balance frictional forces and radial expansion forces. The optimum angle of attack of the

25  
30

expansion cone 2535 will vary as a function of the particular operational features of the expansion operation.

5 The expansion cone 2555 may be fabricated from any number of conventional commercially available materials such as, for example, machine tool steel, nitride steel, titanium, tungsten carbide, ceramics or other similar high strength materials. The expansion cone 2555 is fabricated from D2 machine tool steel in order to optimally provide high strength, and resistance to wear and galling. The outside surface of the expansion cone 2555 has a surface hardness ranging from about 58 to 62 Rockwell C in order to optimally provide high strength and wear resistance.

10 The expansion cone 2555 may be coupled to the outside sealing mandrel 2545 using any number of conventional commercially available mechanical couplings such as, for example, drillpipe connection, oilfield country tubular goods specialty threaded connection, welding, amorphous bonding or a standard threaded connection. The expansion cone 2555 is coupled to the outside sealing mandrel 2545 using a standard  
15 threaded connection in order to optimally provide high strength and easy replacement of the expansion cone 2555.

The casing 2560 is removably coupled to the slips 2525 and expansion cone 2555. The casing 2560 preferably comprises a tubular member. The casing 2560 may be fabricated from any number of conventional commercially available materials such  
20 as, for example, slotted tubulars, oilfield country tubular goods, low alloy steel, carbon steel, stainless steel or other similar high strength materials. The casing 2560 is fabricated from oilfield country tubular goods available from various foreign and domestic steel mills in order to optimally provide high strength using standardized materials.

25 The upper end 2665 of the casing 2560 includes a thin wall section 2670 and an outer annular sealing member 2675. The wall thickness of the thin wall section 2670 is about 50 to 100 % of the regular wall thickness of the casing 2560. In this manner, the upper end 2665 of the casing 2560 may be easily radially expanded and deformed into intimate contact with the lower end of an existing section of wellbore casing. The  
30 lower end of the existing section of casing also includes a thin wall section. In this manner, the radial expansion of the thin walled section 2670 of casing 2560 into the

thin walled section of the existing wellbore casing results in a wellbore casing having a substantially constant inside diameter.

The annular sealing member 2675 may be fabricated from any number of conventional commercially available sealing materials such as, for example, epoxy, rubber, metal, or plastic. The annular sealing member 2675 is fabricated from StrataLock epoxy in order to optimally provide compressibility and resistance to wear.

The outside diameter of the annular sealing member 2675 preferably ranges from about 70 to 95 % of the inside diameter of the lower section of the wellbore casing that the casing 2560 is joined to. In this manner, after radial expansion, the annular sealing member 2670 optimally provides a fluidic seal and also preferably optimally provides sufficient frictional force with the inside surface of the existing section of wellbore casing during the radial expansion of the casing 2560 to support the casing 2560.

The lower end 2680 of the casing 2560 includes a thin wall section 2685 and an outer annular sealing member 2690. The wall thickness of the thin wall section 2685 is about 50 to 100 % of the regular wall thickness of the casing 2560. In this manner, the lower end 2680 of the casing 2560 may be easily expanded and deformed.

Furthermore, in this manner, an other section of casing may be easily joined with the lower end 2680 of the casing 2560 using a radial expansion process. The upper end of the other section of casing also includes a thin wall section. In this manner, the radial expansion of the thin walled section of the upper end of the other casing into the thin walled section 2685 of the lower end 2680 of the casing 2560 results in a wellbore casing having a substantially constant inside diameter.

The annular sealing member 2690 may be fabricated from any number of conventional commercially available sealing materials such as, for example, rubber, metal, plastic or epoxy. The annular sealing member 2690 is fabricated from StrataLock epoxy in order to optimally provide compressibility and resistance to wear.

The outside diameter of the annular sealing member 2690 preferably ranges from about 70 to 95 % of the inside diameter of the lower section of the existing wellbore casing that the casing 2560 is joined to. In this manner, after radial expansion, the annular sealing member 2690 preferably provides a fluidic seal and also preferably provides sufficient frictional force with the inside wall of the wellbore during the radial expansion of the casing 2560 to support the casing 2560.

During operation, the apparatus 2500 is preferably positioned in a wellbore with the upper end 2665 of the casing 2560 positioned in an overlapping relationship with the lower end of an existing wellbore casing. The thin wall section 2670 of the casing 2560 is positioned in opposing overlapping relation with the thin wall section and outer annular sealing member of the lower end of the existing section of wellbore casing. In this manner, the radial expansion of the casing 2560 will compress the thin wall sections and annular compressible members of the upper end 2665 of the casing 2560 and the lower end of the existing wellbore casing into intimate contact. During the positioning of the apparatus 2500 in the wellbore, the casing 2560 is supported by the expansion cone 2555.

After positioning of the apparatus 2500, a first fluidic material is then pumped into the fluid passage 2565. The first fluidic material may comprise any number of conventional commercially available materials such as, for example, cement, water, slag-mix, epoxy or drilling mud. The first fluidic material comprises a hardenable fluidic sealing material such as, for example, cement, epoxy, or slag-mix in order to optimally provide a hardenable outer annular body around the expanded casing 2560.

The first fluidic material may be pumped into the fluid passage 2565 at operating pressures and flow rates ranging, for example, from about 0 to 4,500 psi and 0 to 3,000 gallons/minute. The first fluidic material is pumped into the fluid passage 2565 at operating pressures and flow rates ranging from about 0 to 3,500 psi and 0 to 1,200 gallons/minute in order to optimally provide operational efficiency.

The first fluidic material pumped into the fluid passage 2565 passes through the fluid passages 2570, 2575, 2580, 2590, 2600 and then outside of the apparatus 2500. The first fluidic material then preferably fills the annular region between the outside of the apparatus 2500 and the interior walls of the wellbore.

The plug 2655 is then introduced into the fluid passage 2565. The plug 2655 lodges in the throat passage 2650 and fluidically isolates and blocks off the fluid passage 2590. A couple of volumes of a non-hardenable fluidic material are then pumped into the fluid passage 2565 in order to remove any hardenable fluidic material contained within and to ensure that none of the fluid passages are blocked.

A second fluidic material is then pumped into the fluid passage 2565. The second fluidic material may comprise any number of conventional commercially

available materials such as, for example, water, drilling gases, drilling mud or lubricant. The second fluidic material comprises a non-hardenable fluidic material such as, for example, water, drilling mud, or lubricant in order to optimally provide pressurization of the pressure chamber 2660 and minimize friction.

5 The second fluidic material may be pumped into the fluid passage 2565 at operating pressures and flow rates ranging, for example, from about 0 to 4,500 psi and 0 to 4,500 gallons/minute. The second fluidic material is pumped into the fluid passage 2565 at operating pressures and flow rates ranging from about 0 to 3,500 psi and 0 to 1,200 gallons/minute in order to optimally provide operational efficiency.

10 The second fluidic material pumped into the fluid passage 2565 passes through the fluid passages 2570, 2575, 2580, 2590 and into the pressure chambers 2605 of the slips 2525, and into the pressure chamber 2660. Continued pumping of the second fluidic material pressurizes the pressure chambers 2605 and 2660.

15 The pressurization of the pressure chambers 2605 causes the slip members 2525 to expand in the radial direction and grip the interior surface of the casing 2560. The casing 2560 is then preferably maintained in a substantially stationary position.

The pressurization of the pressure chamber 2660 causes the upper sealing head 2535, outer sealing mandrel 2545 and expansion cone 2555 to move in an axial direction relative to the casing 2560. In this manner, the expansion cone 2555 will  
20 cause the casing 2560 to expand in the radial direction, beginning with the lower end 2685 of the casing 2560.

During the radial expansion process, the casing 2560 is prevented from moving in an upward direction by the slips 2525. A length of the casing 2560 is then expanded in the radial direction through the pressurization of the pressure chamber 2660. The  
25 length of the casing 2560 that is expanded during the expansion process will be proportional to the stroke length of the upper sealing head 2535, outer sealing mandrel 2545, and expansion cone 2555.

Upon the completion of a stroke, the operating pressure of the second fluidic material is reduced and the upper sealing head 2535, outer sealing mandrel 2545, and  
30 expansion cone 2555 drop to their rest positions with the casing 2560 supported by the expansion cone 2555. The position of the drillpipe 2505 is preferably adjusted throughout the radial expansion process in order to maintain the overlapping

relationship between the thin walled sections of the lower end of the existing wellbore casing and the upper end of the casing 2560. The stroking of the expansion cone 2555 is then repeated, as necessary, until the thin walled section 2670 of the upper end 2665 of the casing 2560 is expanded into the thin walled section of the lower end of the existing wellbore casing. In this manner, a wellbore casing is formed including two adjacent sections of casing having a substantially constant inside diameter. This process may then be repeated for the entirety of the wellbore to provide a wellbore casing thousands of feet in length having a substantially constant inside diameter.

During the final stroke of the expansion cone 2555, the slips 2525 are positioned as close as possible to the thin walled section 2670 of the upper end 2665 of the casing 2560 in order minimize slippage between the casing 2560 and the existing wellbore casing at the end of the radial expansion process. Alternatively, or in addition, the outside diameter of the annular sealing member 2675 is selected to ensure sufficient interference fit with the inside diameter of the lower end of the existing casing to prevent axial displacement of the casing 2560 during the final stroke. Alternatively, or in addition, the outside diameter of the annular sealing member 2690 is selected to provide an interference fit with the inside walls of the wellbore at an earlier point in the radial expansion process so as to prevent further axial displacement of the casing 2560. In this final alternative, the interference fit is preferably selected to permit expansion of the casing 2560 by pulling the expansion cone 2555 out of the wellbore, without having to pressurize the pressure chamber 2660.

During the radial expansion process, the pressurized areas of the apparatus 2500 are preferably limited to the fluid passages 2565, 2570, 2575, 2580, and 2590, the pressure chambers 2605 within the slips 2525, and the pressure chamber 2660. No fluid pressure acts directly on the casing 2560. This permits the use of operating pressures higher than the casing 2560 could normally withstand.

Once the casing 2560 has been completely expanded off of the expansion cone 2555, the remaining portions of the apparatus 2500 are removed from the wellbore. The contact pressure between the deformed thin wall sections and compressible annular members of the lower end of the existing casing and the upper end 2665 of the casing 2560 ranges from about 400 to 10,000 psi in order to optimally support the casing 2560 using the existing wellbore casing.

In this manner, the casing 2560 is radially expanded into contact with an existing section of casing by pressurizing the interior fluid passages 2565, 2570, 2575, 2580, and 2590, the pressure chambers of the slips 2605 and the pressure chamber 2660 of the apparatus 2500.

5 As required, the annular body of hardenable fluidic material is then allowed to cure to form a rigid outer annular body about the expanded casing 2560. In the case where the casing 2560 is slotted, the cured fluidic material preferably permeates and envelops the expanded casing 2560. The resulting new section of wellbore casing includes the expanded casing 2560 and the rigid outer annular body. The overlapping  
10 joint between the pre-existing wellbore casing and the expanded casing 2560 includes the deformed thin wall sections and the compressible outer annular bodies. The inner diameter of the resulting combined wellbore casings is substantially constant. In this manner, a mono-diameter wellbore casing is formed. This process of expanding overlapping tubular members having thin wall end portions with compressible annular  
15 bodies into contact can be repeated for the entire length of a wellbore. In this manner, a mono-diameter wellbore casing can be provided for thousands of feet in a subterranean formation.

As the expansion cone 2555 nears the upper end 2665 of the casing 2560, the operating pressure of the second fluidic material is reduced in order to minimize shock  
20 to the apparatus 2500. In an alternative embodiment, the apparatus 2500 includes a shock absorber for absorbing the shock created by the completion of the radial expansion of the casing 2560.

The reduced operating pressure of the second fluidic material ranges from about 100 to 1,000 psi as the expansion cone 2555 nears the end of the casing 2560 in order  
25 to optimally provide reduced axial movement and velocity of the expansion cone 2555. The operating pressure of the second fluidic material is reduced during the return stroke of the apparatus 2500 to the range of about 0 to 500 psi in order minimize the resistance to the movement of the expansion cone 2555 during the return stroke. The stroke length of the apparatus 2500 ranges from about 10 to 45 feet in order to  
30 optimally provide equipments lengths that can be easily handled using typical oil well rigging equipment and also minimize the frequency at which apparatus 2500 must be re-stroked.



In an alternative embodiment, at least a portion of the upper sealing head 2535 includes an expansion cone for radially expanding the casing 2560 during operation of the apparatus 2500 in order to increase the surface area of the casing 2560 acted upon during the radial expansion process. In this manner, the operating pressures can be reduced.

Alternatively, the apparatus 2500 may be used to join a first section of pipeline to an existing section of pipeline. Alternatively, the apparatus 2500 may be used to directly line the interior of a wellbore with a casing, without the use of an outer annular layer of a hardenable material. Alternatively, the apparatus 2500 may be used to expand a tubular support member in a hole.

Referring now to Figures 19, 19a and 19b, another embodiment of an apparatus 2700 for expanding a tubular member will be described. The apparatus 2700 preferably includes a drillpipe 2705, an innerstring adapter 2710, a sealing sleeve 2715, a first inner sealing mandrel 2720, a first upper sealing head 2725, a first lower sealing head 2730, a first outer sealing mandrel 2735, a second inner sealing mandrel 2740, a second upper sealing head 2745, a second lower sealing head 2750, a second outer sealing mandrel 2755, a load mandrel 2760, an expansion cone 2765, a mandrel launcher 2770, a mechanical slip body 2775, mechanical slips 2780, drag blocks 2785, casing 2790, and fluid passages 2795, 2800, 2805, 2810, 2815, 2820, 2825, and 2830.

The drillpipe 2705 is coupled to the innerstring adapter 2710. During operation of the apparatus 2700, the drillpipe 2705 supports the apparatus 2700. The drillpipe 2705 preferably comprises a substantially hollow tubular member or members. The drillpipe 2705 may be fabricated from any number of conventional commercially available materials such as, for example, oilfield country tubular goods, low alloy steel, carbon steel, stainless steel, or other similar high strength materials. The drillpipe 2705 is fabricated from coiled tubing in order to facilitate the placement of the apparatus 2700 in non-vertical wellbores. The drillpipe 2705 may be coupled to the innerstring adapter 2710 using any number of conventional commercially available mechanical couplings such as, for example, drillpipe connection, oilfield country tubular goods specialty threaded connection, or a standard threaded connection. The drillpipe 2705 is removably coupled to the innerstring adapter 2710 by a drillpipe connection in order to optimally provide high strength and easy disassembly.



The drillpipe 2705 preferably includes a fluid passage 2795 that is adapted to convey fluidic materials from a surface location into the fluid passage 2800. The fluid passage 2795 is adapted to convey fluidic materials such as, for example, cement, epoxy, water, drilling mud or lubricants at operating pressures and flow rates ranging from about 0 to 9,000 psi and 0 to 3,000 gallons/minute.

The innerstring adapter 2710 is coupled to the drill string 2705 and the sealing sleeve 2715. The innerstring adapter 2710 preferably comprises a substantially hollow tubular member or members. The innerstring adapter 2710 may be fabricated from any number of conventional commercially available materials such as, for example, oilfield country tubular goods, low alloy steel, carbon steel, stainless steel or other similar high strength materials. The innerstring adapter 2710 is fabricated from stainless steel in order to optimally provide high strength, corrosion resistance, and low friction surfaces.

The innerstring adapter 2710 may be coupled to the drill string 2705 using any number of conventional commercially available mechanical couplings such as, for example, drillpipe connection, oilfield country tubular goods specialty threaded connection, or a standard threaded connection. The innerstring adapter 2710 is removably coupled to the drill pipe 2705 by a standard threaded connection in order to optimally provide high strength and easy disassembly. The innerstring adapter 2710 may be coupled to the sealing sleeve 2715 using any number of conventional commercially available mechanical couplings such as, for example, drillpipe connection, oilfield country tubular goods specialty type threaded connection, ratchet-latch type threaded connection or a standard threaded connection. The innerstring adapter 2710 is removably coupled to the sealing sleeve 2715 by a standard threaded connection.

The innerstring adapter 2710 preferably includes a fluid passage 2800 that is adapted to convey fluidic materials from the fluid passage 2795 into the fluid passage 2805. The fluid passage 2800 is adapted to convey fluidic materials such as, for example, cement, epoxy, water, drilling mud or lubricants at operating pressures and flow rates ranging from about 0 to 9,000 psi and 0 to 3,000 gallons/minute.

The sealing sleeve 2715 is coupled to the innerstring adapter 2710 and the first inner sealing mandrel 2720. The sealing sleeve 2715 preferably comprises a

substantially hollow tubular member or members. The sealing sleeve 2715 may be fabricated from any number of conventional commercially available materials such as, for example, oilfield country tubular goods, low alloy steel, carbon steel, stainless steel or other similar high strength materials. The sealing sleeve 2715 is fabricated from stainless steel in order to optimally provide high strength, corrosion resistance, and low friction surfaces.

The sealing sleeve 2715 may be coupled to the innerstring adapter 2710 using any number of conventional commercially available mechanical couplings such as, for example, drillpipe connection, oilfield country tubular goods specialty type threaded connection, welding, amorphous bonding, or a standard threaded connection. The sealing sleeve 2715 is removably coupled to the innerstring adapter 2710 by a standard threaded connector. The sealing sleeve 2715 may be coupled to the first inner sealing mandrel 2720 using any number of conventional commercially available mechanical couplings such as, for example, drillpipe connection, oilfield country tubular goods specialty type threaded connection, welding, amorphous bonding or a standard threaded connection. The sealing sleeve 2715 is removably coupled to the inner sealing mandrel 2720 by a standard threaded connection.

The sealing sleeve 2715 preferably includes a fluid passage 2802 that is adapted to convey fluidic materials from the fluid passage 2800 into the fluid passage 2805. The fluid passage 2802 is adapted to convey fluidic materials such as, for example, cement, epoxy, water, drilling mud or lubricants at operating pressures and flow rates ranging from about 0 to 9,000 psi and 0 to 3,000 gallons/minute.

The first inner sealing mandrel 2720 is coupled to the sealing sleeve 2715 and the first lower sealing head 2730. The first inner sealing mandrel 2720 preferably comprises a substantially hollow tubular member or members. The first inner sealing mandrel 2720 may be fabricated from any number of conventional commercially available materials such as, for example, oilfield country tubular goods, low alloy steel, carbon steel, stainless steel or other similar high strength materials. The first inner sealing mandrel 2720 is fabricated from stainless steel in order to optimally provide high strength, corrosion resistance, and low friction surfaces.

The first inner sealing mandrel 2720 may be coupled to the sealing sleeve 2715 using any number of conventional commercially available mechanical couplings such

as, for example, drillpipe connection oilfield country tubular goods specialty threaded connection, welding, amorphous bonding, or a standard threaded connection. The first inner sealing mandrel 2720 is removably coupled to the sealing sleeve 2715 by a standard threaded connection. The first inner sealing mandrel 2720 may be coupled to the first lower sealing head 2730 using any number of conventional commercially available mechanical couplings such as, for example, drillpipe connection, oilfield country tubular goods specialty type threaded connection, welding, amorphous bonding, or a standard threaded connection. The first inner sealing mandrel 2720 is removably coupled to the first lower sealing head 2730 by a standard threaded connection.

The first inner sealing mandrel 2720 preferably includes a fluid passage 2805 that is adapted to convey fluidic materials from the fluid passage 2802 into the fluid passage 2810. The fluid passage 2805 is adapted to convey fluidic materials such as, for example, cement, epoxy, water, drilling mud or lubricants at operating pressures and flow rates ranging from about 0 to 9,000 psi and 0 to 3,000 gallons/minute.

The first upper sealing head 2725 is coupled to the first outer sealing mandrel 2735, the second upper sealing head 2745, the second outer sealing mandrel 2755, and the expansion cone 2765. The first upper sealing head 2725 is also movably coupled to the outer surface of the first inner sealing mandrel 2720 and the inner surface of the casing 2790. In this manner, the first upper sealing head 2725 reciprocates in the axial direction. The radial clearance between the inner cylindrical surface of the first upper sealing head 2725 and the outer surface of the first inner sealing mandrel 2720 may range, for example, from about 0.0025 to 0.05 inches. The radial clearance between the inner cylindrical surface of the first upper sealing head 2725 and the outer surface of the first inner sealing mandrel 2720 ranges from about 0.005 to 0.125 inches in order to optimally provide minimal radial clearance. The radial clearance between the outer cylindrical surface of the first upper sealing head 2725 and the inner surface of the casing 2790 may range, for example, from about 0.025 to 0.375 inches. The radial clearance between the outer cylindrical surface of the first upper sealing head 2725 and the inner surface of the casing 2790 ranges from about 0.025 to 0.125 inches in order to optimally provide stabilization for the expansion cone 2765 during the expansion process.



The first upper sealing head 2725 preferably comprises an annular member having substantially cylindrical inner and outer surfaces. The first upper sealing head 2725 may be fabricated from any number of conventional commercially available materials such as, for example, oilfield country tubular goods, low alloy steel, carbon steel, stainless steel or other similar high strength materials. The first upper sealing head 2725 is fabricated from stainless steel in order to optimally provide high strength, corrosion resistance and low friction surfaces. The inner surface of the first upper sealing head 2725 preferably includes one or more annular sealing members 2835 for sealing the interface between the first upper sealing head 2725 and the first inner sealing mandrel 2720. The sealing members 2835 may comprise any number of conventional commercially available annular sealing members such as, for example, o-rings, polypak seals or metal spring energized seals. The sealing members 2835 comprise polypak seals available from Parker Seals in order to optimally provide sealing for long axial strokes.

The first upper sealing head 2725 includes a shoulder 2840 for supporting the first upper sealing head 2725 on the first lower sealing head 2730.

The first upper sealing head 2725 may be coupled to the first outer sealing mandrel 2735 using any number of conventional commercially available mechanical couplings such as, for example, drillpipe connection, oilfield country tubular goods specialty threaded connection, welding, amorphous bonding or a standard threaded connection. The first upper sealing head 2725 is removably coupled to the first outer sealing mandrel 2735 by a standard threaded connection. The mechanical coupling between the first upper sealing head 2725 and the first outer sealing mandrel 2735 includes one or more sealing members 2845 for fluidically sealing the interface between the first upper sealing head 2725 and the first outer sealing mandrel 2735. The sealing members 2845 may comprise any number of conventional commercially available sealing members such as, for example, o-rings, polypak seals or metal spring energized seals. The sealing members 2845 comprise polypak seals available from Parker Seals in order to optimally provide sealing for long axial strokes.

The first lower sealing head 2730 is coupled to the first inner sealing mandrel 2720 and the second inner sealing mandrel 2740. The first lower sealing head 2730 is also movably coupled to the inner surface of the first outer sealing mandrel 2735. In

this manner, the first upper sealing head 2725 and first outer sealing mandrel 2735 reciprocate in the axial direction. The radial clearance between the outer surface of the first lower sealing head 2730 and the inner surface of the first outer sealing mandrel 2735 may range, for example, from about 0.0025 to 0.05 inches. The radial clearance  
5 between the outer surface of the first lower sealing head 2730 and the inner surface of the first outer sealing mandrel 2735 ranges from about 0.005 to 0.01 inches in order to optimally provide minimal radial clearance.

The first lower sealing head 2730 preferably comprises an annular member having substantially cylindrical inner and outer surfaces. The first lower sealing head  
10 2730 may be fabricated from any number of conventional commercially available materials such as, for example, oilfield country tubular goods, low alloy steel, carbon steel, stainless steel or other similar high strength materials. The first lower sealing head 2730 is fabricated from stainless steel in order to optimally provide high strength, corrosion resistance, and low friction surfaces. The outer surface of the first lower  
15 sealing head 2730 preferably includes one or more annular sealing members 2850 for sealing the interface between the first lower sealing head 2730 and the first outer sealing mandrel 2735. The sealing members 2850 may comprise any number of conventional commercially available annular sealing members such as, for example, o-rings, polypak seals or metal spring energized seals. The sealing members 2850  
20 comprise polypak seals available from Parker Seals in order to optimally provide sealing for long axial strokes.

The first lower sealing head 2730 may be coupled to the first inner sealing mandrel 2720 using any number of conventional commercially available mechanical couplings such as, for example, oilfield country tubular goods specialty threaded  
25 connections, welding, amorphous bonding, or standard threaded connection. The first lower sealing head 2730 is removably coupled to the first inner sealing mandrel 2720 by a standard threaded connection. The mechanical coupling between the first lower sealing head 2730 and the first inner sealing mandrel 2720 includes one or more sealing members 2855 for fluidically sealing the interface between the first lower sealing  
30 head 2730 and the first inner sealing mandrel 2720. The sealing members 2855 may comprise any number of conventional commercially available sealing members such as, for example, o-rings, polypak seals or metal spring energized seals. The sealing

members 2855 comprise polypak seals available from Parker Seals in order to optimally provide sealing for long axial strokes.

5 The first lower sealing head 2730 may be coupled to the second inner sealing mandrel 2740 using any number of conventional commercially available mechanical couplings such as, for example, oilfield country tubular goods specialty threaded connection, welding, amorphous bonding, or a standard threaded connection. The lower sealing head 2730 is removably coupled to the second inner sealing mandrel 2740 by a standard threaded connection. The mechanical coupling between the first lower sealing head 2730 and the second inner sealing mandrel 2740 includes one or 10 more sealing members 2860 for fluidically sealing the interface between the first lower sealing head 2730 and the second inner sealing mandrel 2740. The sealing members 2860 may comprise any number of conventional commercially available sealing members such as, for example, o-rings, polypak seals or metal spring energized seals. The sealing members 2860 comprise polypak seals available from Parker Seals in 15 order to optimally provide sealing for long axial strokes.

The first outer sealing mandrel 2735 is coupled to the first upper sealing head 2725, the second upper sealing head 2745, the second outer sealing mandrel 2755, and the expansion cone 2765. The first outer sealing mandrel 2735 is also movably coupled to the inner surface of the casing 2790 and the outer surface of the first lower 20 sealing head 2730. In this manner, the first upper sealing head 2725, first outer sealing mandrel 2735, second upper sealing head 2745, second outer sealing mandrel 2755, and the expansion cone 2765 reciprocate in the axial direction. The radial clearance between the outer surface of the first outer sealing mandrel 2735 and the inner surface of the casing 2790 may range, for example, from about 0.025 to 0.375 inches. The 25 radial clearance between the outer surface of the first outer sealing mandrel 2735 and the inner surface of the casing 2790 ranges from about 0.025 to 0.125 inches in order to optimally provide stabilization for the expansion cone 2765 during the expansion process. The radial clearance between the inner surface of the first outer sealing mandrel 2735 and the outer surface of the first lower sealing head 2730 may range, for 30 example, from about 0.0025 to 0.05 inches. The radial clearance between the inner surface of the first outer sealing mandrel 2735 and the outer surface of the first lower

sealing head 2730 ranges from about 0.005 to 0.01 inches in order to optimally provide minimal radial clearance.

The outer sealing mandrel 2735 preferably comprises an annular member having substantially cylindrical inner and outer surfaces. The first outer sealing mandrel 2735 may be fabricated from any number of conventional commercially available materials such as, for example, oilfield country tubular goods, low alloy steel, carbon steel, stainless steel or other similar high strength materials. The first outer sealing mandrel 2735 is fabricated from stainless steel in order to optimally provide high strength, corrosion resistance, and low friction surfaces.

The first outer sealing mandrel 2735 may be coupled to the first upper sealing head 2725 using any number of conventional commercially available mechanical couplings such as, for example, oilfield country tubular goods, welding, amorphous bonding, or a standard threaded connection. The first outer sealing mandrel 2735 is removably coupled to the first upper sealing head 2725 by a standard threaded connection. The first outer sealing mandrel 2735 may be coupled to the second upper sealing head 2745 using any number of conventional commercially available mechanical couplings such as, for example, oilfield country tubular goods specialty threaded connection, welding, amorphous bonding, or a standard threaded connection. The first outer sealing mandrel 2735 is removably coupled to the second upper sealing head 2745 by a standard threaded connection.

The second inner sealing mandrel 2740 is coupled to the first lower sealing head 2730 and the second lower sealing head 2750. The second inner sealing mandrel 2740 preferably comprises a substantially hollow tubular member or members. The second inner sealing mandrel 2740 may be fabricated from any number of conventional commercially available materials such as, for example, oilfield country tubular goods, low alloy steel, carbon steel, stainless steel or other similar high strength materials. The second inner sealing mandrel 2740 is fabricated from stainless steel in order to optimally provide high strength, corrosion resistance, and low friction surfaces.

The second inner sealing mandrel 2740 may be coupled to the first lower sealing head 2730 using any number of conventional commercially available mechanical couplings such as, for example, oilfield country tubular goods specialty



threaded connection, welding, amorphous bonding, or a standard threaded connection.

The second inner sealing mandrel 2740 is removably coupled to the first lower sealing head 2740 by a standard threaded connection. The mechanical coupling between the second inner sealing mandrel 2740 and the first lower sealing head 2730 preferably includes sealing members 2860.

The second inner sealing mandrel 2740 may be coupled to the second lower scaling head 2750 using any number of conventional commercially available mechanical couplings such as, for example, oilfield country tubular goods specialty threaded connection, welding, amorphous bonding, or a standard threaded connection.

The second inner sealing mandrel 2720 is removably coupled to the second lower scaling head 2750 by a standard threaded connection. The mechanical coupling between the second inner sealing mandrel 2740 and the second lower scaling head 2750 includes one or more sealing members 2865. The sealing members 2865 may comprise any number of conventional commercially available seals such as, for example, o-rings, polypak seals or metal spring energized seals. The sealing members 2865 comprise polypak seals available from Parker Seals.

The second inner sealing mandrel 2740 preferably includes a fluid passage 2810 that is adapted to convey fluidic materials from the fluid passage 2805 into the fluid passage 2815. The fluid passage 2810 is adapted to convey fluidic materials such as, for example, cement, epoxy, water, drilling mud or lubricants at operating pressures and flow rates ranging from about 0 to 9,000 psi and 0 to 3,000 gallons/minute.

The second upper scaling head 2745 is coupled to the first upper sealing head 2725, the first outer sealing mandrel 2735, the second outer sealing mandrel 2755, and the expansion cone 2765. The second upper scaling head 2745 is also movably coupled to the outer surface of the second inner sealing mandrel 2740 and the inner surface of the casing 2790. In this manner, the second upper scaling head 2745 reciprocates in the axial direction. The radial clearance between the inner cylindrical surface of the second upper scaling head 2745 and the outer surface of the second inner sealing mandrel 2740 may range, for example, from about 0.0025 to 0.05 inches. The radial clearance between the inner cylindrical surface of the second upper scaling head 2745 and the outer surface of the second inner sealing mandrel 2740 ranges from about 0.005 to 0.01 inches in order to optimally provide minimal radial clearance. The radial

clearance between the outer cylindrical surface of the second upper sealing head 2745 and the inner surface of the casing 2790 may range, for example, from about 0.025 to .375 inches. The radial clearance between the outer cylindrical surface of the second upper sealing head 2745 and the inner surface of the casing 2790 ranges from about 0.025 to 0.125 inches in order to optimally provide stabilization for the expansion cone 2765 during the expansion process.

The second upper sealing head 2745 preferably comprises an annular member having substantially cylindrical inner and outer surfaces. The second upper sealing head 2745 may be fabricated from any number of conventional commercially available materials such as, for example, oilfield country tubular goods, low alloy steel, carbon steel, stainless steel or other similar high strength materials. The second upper sealing head 2745 is fabricated from stainless steel in order to optimally provide high strength, corrosion resistance, and low friction surfaces. The inner surface of the second upper sealing head 2745 preferably includes one or more annular sealing members 2870 for sealing the interface between the second upper sealing head 2745 and the second inner sealing mandrel 2740. The sealing members 2870 may comprise any number of conventional commercially available annular sealing members such as, for example, o-rings, polypak seals, or metal spring energized seals. The sealing members 2870 comprise polypak seals available from Parker Seals in order to optimally provide sealing for long axial strokes.

The second upper sealing head 2745 includes a shoulder 2875 for supporting the second upper sealing head 2745 on the second lower sealing head 2750.

The second upper sealing head 2745 may be coupled to the first outer sealing mandrel 2735 using any number of conventional commercially available mechanical couplings such as, for example, drillpipe connection, oilfield country tubular goods specialty threaded connection, ratchet-latch type threaded connection, or a standard threaded connection. The second upper sealing head 2745 is removably coupled to the first outer sealing mandrel 2735 by a standard threaded connection. The mechanical coupling between the second upper sealing head 2745 and the first outer sealing mandrel 2735 includes one or more sealing members 2880 for fluidically sealing the interface between the second upper sealing head 2745 and the first outer sealing mandrel 2735. The sealing members 2880 may comprise any number of conventional

commercially available sealing members such as, for example, o-rings, polypak seals or metal spring energized seals. The sealing members 2880 comprise polypak seals available from Parker Seals in order to optimally provide sealing for a long axial stroke.

5           The second upper sealing head 2745 may be coupled to the second outer sealing mandrel 2755 using any number of conventional commercially available mechanical couplings such as, for example, drillpipe connection, oilfield country tubular goods specialty type threaded connection, or a standard threaded connection. The second upper sealing head 2745 is removably coupled to the second outer sealing mandrel  
10 2755 by a standard threaded connection. The mechanical coupling between the second upper sealing head 2745 and the second outer sealing mandrel 2755 includes one or more sealing members 2885 for fluidically sealing the interface between the second upper sealing head 2745 and the second outer sealing mandrel 2755. The sealing members 2885 may comprise any number of conventional commercially  
15 available sealing members such as, for example, o-rings, polypak seals or metal spring energized seals. The sealing members 2885 comprise polypak seals available from Parker Seals in order to optimally provide sealing for long axial strokes.

The second lower sealing head 2750 is coupled to the second inner scaling mandrel 2740 and the load mandrel 2760. The second lower sealing head 2750 is also  
20 movably coupled to the inner surface of the second outer sealing mandrel 2755. In this manner, the first upper sealing head 2725, the first outer scaling mandrel 2735, second upper sealing head 2745, second outer scaling mandrel 2755, and the expansion cone 2765 reciprocate in the axial direction. The radial clearance between the outer surface of the second lower sealing head 2750 and the inner surface of the second outer scaling  
25 mandrel 2755 may range, for example, from about 0.0025 to 0.05 inches. The radial clearance between the outer surface of the second lower sealing head 2750 and the inner surface of the second outer sealing mandrel 2755 ranges from about 0.005 to 0.01 inches in order to optimally provide minimal radial clearance.

The second lower sealing head 2750 preferably comprises an annular member  
30 having substantially cylindrical inner and outer surfaces. The second lower sealing head 2750 may be fabricated from any number of conventional commercially available materials such as, for example, oilfield country tubular goods, low alloy steel, carbon

5 steel, stainless steel or other similar high strength materials. The second lower sealing head 2750 is fabricated from stainless steel in order to optimally provide high strength, corrosion resistance, and low friction surfaces. The outer surface of the second lower sealing head 2750 preferably includes one or more annular sealing members 2890 for sealing the interface between the second lower sealing head 2750 and the second outer sealing mandrel 2755. The sealing members 2890 may comprise any number of conventional commercially available annular sealing members such as, for example, o-rings, polypak seals or metal spring energized seals. The sealing members 2890 comprise polypak seals available from Parker Seals in order to optimally provide sealing for long axial strokes.

15 The second lower sealing head 2750 may be coupled to the second inner sealing mandrel 2740 using any number of conventional commercially available mechanical couplings such as, for example, drillpipe connection, oilfield country tubular goods specialty threaded connection, ratchet-latch type threaded connection, or a standard threaded connection. The second lower sealing head 2750 is removably coupled to the second inner sealing mandrel 2740 by a standard threaded connection. The mechanical coupling between the second lower sealing head 2750 and the second inner sealing mandrel 2740 includes one or more sealing members 2895 for fluidically sealing the interface between the second sealing head 2750 and the second sealing mandrel 2740. The sealing members 2895 may comprise any number of conventional commercially available sealing members such as, for example, o-rings, polypak seals or metal spring energized seals. The sealing members 2895 comprise polypak seals available from Parker Seals in order to optimally provide sealing for a long axial stroke.

25 The second lower sealing head 2750 may be coupled to the load mandrel 2760 using any number of conventional commercially available mechanical couplings such as, for example, drillpipe connection, oilfield tubular goods specialty threaded connection, ratchet-latch type threaded connection, or a standard threaded connection. The second lower sealing head 2750 is removably coupled to the load mandrel 2760 by a standard threaded connection. The mechanical coupling between the second lower sealing head 2750 and the load mandrel 2760 includes one or more sealing members 2900 for fluidically sealing the interface between the second lower sealing head 2750

and the load mandrel 2760. The sealing members 2900 may comprise any number of conventional commercially available sealing members such as, for example, o-rings, polypak seals or metal spring energized seals. The sealing members 2900 comprise polypak seals available from Parker Seals in order to optimally provide sealing for long axial strokes.

The second lower sealing head 2750 includes a throat passage 2905 fluidically coupled between the fluid passages 2810 and 2815. The throat passage 2905 is preferably of reduced size and is adapted to receive and engage with a plug 2910, or other similar device. In this manner, the fluid passage 2810 is fluidically isolated from the fluid passage 2815. In this manner, the pressure chambers 2915 and 2920 are pressurized. The use of a plurality of pressure chambers in the apparatus 2700 permits the effective driving force to be multiplied. While illustrated using a pair of pressure chambers, 2915 and 2920, the apparatus 2700 may be further modified to employ additional pressure chambers.

The second outer sealing mandrel 2755 is coupled to the first upper sealing head 2725, the first outer sealing mandrel 2735, the second upper sealing head 2745, and the expansion cone 2765. The second outer sealing mandrel 2755 is also movably coupled to the inner surface of the casing 2790 and the outer surface of the second lower sealing head 2750. In this manner, the first upper sealing head 2725, first outer sealing mandrel 2735, second upper sealing head 2745, second outer sealing mandrel 2755, and the expansion cone 2765 reciprocate in the axial direction.

The radial clearance between the outer surface of the second outer sealing mandrel 2755 and the inner surface of the casing 2790 may range, for example, from about 0.025 to 0.375 inches. The radial clearance between the outer surface of the second outer sealing mandrel 2755 and the inner surface of the casing 2790 ranges from about 0.025 to 0.125 inches in order to optimally provide stabilization for the expansion cone 2765 during the expansion process. The radial clearance between the inner surface of the second outer sealing mandrel 2755 and the outer surface of the second lower sealing head 2750 may range, for example, from about 0.0025 to 0.05 inches. The radial clearance between the inner surface of the second outer sealing mandrel 2755 and the outer surface of the second lower sealing head 2750 ranges from about 0.005 to 0.01 inches in order to optimally provide minimal radial clearance.

The second outer sealing mandrel 2755 preferably comprises an annular member having substantially cylindrical inner and outer surfaces. The second outer sealing mandrel 2755 may be fabricated from any number of conventional commercially available materials such as, for example, oilfield country tubular goods, low alloy steel, carbon steel, stainless steel or other similar high strength materials. The second outer sealing mandrel 2755 is fabricated from stainless steel in order to optimally provide high strength, corrosion resistance, and low friction surfaces.

The second outer sealing mandrel 2755 may be coupled to the second upper sealing head 2745 using any number of conventional commercially available mechanical couplings such as, for example, drillpipe connection, oilfield country tubular goods specialty threaded connection, ratchet-latch type threaded connection or a standard threaded connection. The second outer sealing mandrel 2755 is removably coupled to the second upper sealing head 2745 by a standard threaded connection. The second outer sealing mandrel 2755 may be coupled to the expansion cone 2765 using any number of conventional commercially available mechanical couplings such as, for example, drillpipe connection, oilfield country tubular goods specialty type threaded connection, ratchet-latch type threaded connection, or a standard threaded connection. The second outer sealing mandrel 2755 is removably coupled to the expansion cone 2765 by a standard threaded connection.

The load mandrel 2760 is coupled to the second lower sealing head 2750 and the mechanical slip body 2755. The load mandrel 2760 preferably comprises an annular member having substantially cylindrical inner and outer surfaces. The load mandrel 2760 may be fabricated from any number of conventional commercially available materials such as, for example, oilfield country tubular goods, low alloy steel, carbon steel, stainless steel or other similar high strength materials. The load mandrel 2760 is fabricated from stainless steel in order to optimally provide high strength, corrosion resistance, and low friction surfaces.

The load mandrel 2760 may be coupled to the second lower sealing head 2750 using any number of conventional commercially available mechanical couplings such as, for example, drillpipe connection, oilfield country tubular goods specialty type threaded connection, ratchet-latch type threaded connection, or a standard threaded connection. The load mandrel 2760 is removably coupled to the second lower sealing

head 2750 by a standard threaded connection. The load mandrel 2760 may be coupled to the mechanical slip body 2775 using any number of conventional commercially available mechanical couplings such as, for example, drillpipe connection, oilfield country tubular goods specialty type threaded connection, ratchet-latch type threaded connection or a standard threaded connection. The load mandrel 2760 is removably coupled to the mechanical slip body 2775 by a standard threaded connection.

The load mandrel 2760 preferably includes a fluid passage 2815 that is adapted to convey fluidic materials from the fluid passage 2810 to the fluid passage 2820. The fluid passage 2815 is adapted to convey fluidic materials such as, for example, cement, epoxy, water, drilling mud or lubricants at operating pressures and flow rates ranging from about 0 to 9,000 psi and 0 to 3,000 gallons/minute.

The expansion cone 2765 is coupled to the second outer sealing mandrel 2755. The expansion cone 2765 is also movably coupled to the inner surface of the casing 2790. In this manner, the first upper sealing head 2725, first outer sealing mandrel 2735, second upper sealing head 2745, second outer sealing mandrel 2755, and the expansion cone 2765 reciprocate in the axial direction. The reciprocation of the expansion cone 2765 causes the casing 2790 to expand in the radial direction.

The expansion cone 2765 preferably comprises an annular member having substantially cylindrical inner and conical outer surfaces. The outside radius of the outside conical surface may range, for example, from about 2 to 34 inches. The outside radius of the outside conical surface ranges from about 3 to 28 inches in order to optimally provide expansion cone dimensions that accommodate the typical range of casings. The axial length of the expansion cone 2765 may range, for example, from about 2 to 8 times the largest outer diameter of the expansion cone 2765. The axial length of the expansion cone 2765 ranges from about 3 to 5 times the largest outer diameter of the expansion cone 2765 in order to optimally provide stabilization and centralization of the expansion cone 2765. The angle of attack of the expansion cone 2765 ranges from about 5 to 30 degrees in order to optimally balance frictional forces and radial expansion forces.

The expansion cone 2765 may be fabricated from any number of conventional commercially available materials such as, for example, machine tool steel, nitride steel, titanium, tungsten carbide, ceramics or other similar high strength materials. The

expansion cone 2765 is fabricated from D2 machine tool steel in order to optimally provide high strength and resistance to corrosion and galling. The outside surface of the expansion cone 2765 has a surface hardness ranging from about 58 to 62 Rockwell C in order to optimally provide high strength and resistance to wear and galling.

5 The expansion cone 2765 may be coupled to the second outside sealing mandrel 2765 using any number of conventional commercially available mechanical couplings such as, for example, drillpipe connection, oilfield country tubular goods specialty type threaded connection, ratchet-latch type threaded connection or a standard threaded connection. The expansion cone 2765 is coupled to the second  
10 outside sealing mandrel 2765 using a standard threaded connection in order to optimally provide high strength and easy replacement of the expansion cone 2765.

The mandrel launcher 2770 is coupled to the casing 2790. The mandrel launcher 2770 comprises a tubular section of casing having a reduced wall thickness compared to the casing 2790. The wall thickness of the mandrel launcher 2770 is  
15 about 50 to 100 % of the wall thickness of the casing 2790. The wall thickness of the mandrel launcher 2770 may range , for example, from about 0.15 to 1.5 inches. The wall thickness of the mandrel launcher 2770 ranges from about 0.25 to 0.75 inches. In this manner, the initiation of the radial expansion of the casing 2790 is facilitated, the placement of the apparatus 2700 within a wellbore casing and wellbore is facilitated,  
20 and the mandrel launcher 2770 has a burst strength approximately equal to that of the casing 2790.

The mandrel launcher 2770 may be coupled to the casing 2790 using any number of conventional mechanical couplings such as, for example, a standard threaded connection. The mandrel launcher 2770 may be fabricated from any number  
25 of conventional commercially available materials such as, for example, oilfield country tubular goods, low alloy steel, carbon steel, stainless steel, or other similar high strength materials. The mandrel launcher 2770 is fabricated from oilfield country tubular goods of higher strength than that of the casing 2790 but with a reduced wall thickness in order to optimally provide a small compact tubular container having a  
30 burst strength approximately equal to that of the casing 2790.

The mechanical slip body 2775 is coupled to the load mandrel 2760, the mechanical slips 2780, and the drag blocks 2785. The mechanical slip body 2775



preferably comprises a tubular member having an inner passage 2820 fluidically coupled to the passage 2815. In this manner, fluidic materials may be conveyed from the passage 2820 to a region outside of the apparatus 2700.

5 The mechanical slip body 2775 may be coupled to the load mandrel 2760 using any number of conventional mechanical couplings. The mechanical slip body 2775 is removably coupled to the load mandrel 2760 using a standard threaded connection in order to optimally provide high strength and easy disassembly. The mechanical slip body 2775 may be coupled to the mechanical slips 2780 using any number of conventional mechanical couplings. The mechanical slip body 2775 is removably  
10 coupled to the mechanical slips 2780 using threaded connections and sliding steel retainer rings in order to optimally provide a high strength attachment. The mechanical slip body 2775 may be coupled to the drag blocks 2785 using any number of conventional mechanical couplings. The mechanical slip body 2775 is removably coupled to the drag blocks 2785 using threaded connections and sliding steel retainer  
15 rings in order to optimally provide a high strength attachment.

The mechanical slip body 2775 preferably includes a fluid passage 2820 that is adapted to convey fluidic materials from the fluid passage 2815 to the region outside of the apparatus 2700. The fluid passage 2820 is adapted to convey fluidic materials such as, for example, cement, epoxy, water, drilling mud or lubricants at operating  
20 pressures and flow rates ranging from about 0 to 9,000 psi and 0 to 3,000 gallons/minute.

The mechanical slips 2780 are coupled to the outside surface of the mechanical slip body 2775. During operation of the apparatus 2700, the mechanical slips 2780 prevent upward movement of the casing 2790 and mandrel launcher 2770. In this  
25 manner, during the axial reciprocation of the expansion cone 2765, the casing 2790 and mandrel launcher 2770 are maintained in a substantially stationary position. In this manner, the mandrel launcher 2765 and casing 2790 and mandrel launcher 2770 are expanded in the radial direction by the axial movement of the expansion cone 2765.

30 The mechanical slips 2780 may comprise any number of conventional commercially available mechanical slips such as, for example, RTTS packer tungsten carbide mechanical slips, RTTS packer wicker type mechanical slips or Model 3L.

retrievable bridge plug tungsten carbide upper mechanical slips. The mechanical slips 2780 comprise RTTS packer tungsten carbide mechanical slips available from Halliburton Energy Services in order to optimally provide resistance to axial movement of the casing 2790 and mandrel launcher 2770 during the expansion process.

The drag blocks 2785 are coupled to the outside surface of the mechanical slip body 2775. During operation of the apparatus 2700, the drag blocks 2785 prevent upward movement of the casing 2790 and mandrel launcher 2770. In this manner, during the axial reciprocation of the expansion cone 2765, the casing 2790 and mandrel launcher 2770 are maintained in a substantially stationary position. In this manner, the mandrel launcher 2770 and casing 2790 are expanded in the radial direction by the axial movement of the expansion cone 2765.

The drag blocks 2785 may comprise any number of conventional commercially available mechanical slips such as, for example, RTTS packer mechanical drag blocks or Model 3L retrievable bridge plug drag blocks. The drag blocks 2785 comprise RTTS packer mechanical drag blocks available from Halliburton Energy Services in order to optimally provide resistance to axial movement of the casing 2790 and mandrel launcher 2770 during the expansion process.

The casing 2790 is coupled to the mandrel launcher 2770. The casing 2790 is further removably coupled to the mechanical slips 2780 and drag blocks 2785. The casing 2790 preferably comprises a tubular member. The casing 2790 may be fabricated from any number of conventional commercially available materials such as, for example, slotted tubulars, oilfield country tubular goods, low alloy steel, carbon steel, stainless steel or other similar high strength materials. The casing 2790 is fabricated from oilfield country tubular goods available from various foreign and domestic steel mills in order to optimally provide high strength using standardized materials. The upper end of the casing 2790 includes one or more sealing members positioned about the exterior of the casing 2790.

During operation, the apparatus 2700 is positioned in a wellbore with the upper end of the casing 2790 positioned in an overlapping relationship within an existing wellbore casing. In order minimize surge pressures within the borehole during placement of the apparatus 2700, the fluid passage 2795 is preferably provided with

one or more pressure relief passages. During the placement of the apparatus 2700 in the wellbore, the casing 2790 is supported by the expansion cone 2765.

After positioning of the apparatus 2700 within the bore hole in an overlapping relationship with an existing section of wellbore casing, a first fluidic material is pumped into the fluid passage 2795 from a surface location. The first fluidic material is conveyed from the fluid passage 2795 to the fluid passages 2800, 2802, 2805, 2810, 2815, and 2820. The first fluidic material will then exit the apparatus 2700 and fill the annular region between the outside of the apparatus 2700 and the interior walls of the bore hole.

The first fluidic material may comprise any number of conventional commercially available materials such as, for example, epoxy, drilling mud, slag mix, water or cement. The first fluidic material comprises a hardenable fluidic sealing material such as, for example, slag mix, epoxy, or cement. In this manner, a wellbore casing having an outer annular layer of a hardenable material may be formed.

The first fluidic material may be pumped into the apparatus 2700 at operating pressures and flow rates ranging, for example, from about 0 to 4,500 psi and 0 to 3,000 gallons/minute. The first fluidic material is pumped into the apparatus 2700 at operating pressures and flow rates ranging from about 0 to 3,500 psi and 0 to 1,200 gallons/minute in order to optimally provide operational efficiency.

At a predetermined point in the injection of the first fluidic material such as, for example, after the annular region outside of the apparatus 2700 has been filled to a predetermined level, a plug 2910, dart, or other similar device is introduced into the first fluidic material. The plug 2910 lodges in the throat passage 2905 thereby fluidically isolating the fluid passage 2810 from the fluid passage 2815.

After placement of the plug 2910 in the throat passage 2905, a second fluidic material is pumped into the fluid passage 2795 in order to pressurize the pressure chambers 2915 and 2920. The second fluidic material may comprise any number of conventional commercially available materials such as, for example, water, drilling gases, drilling mud or lubricants. The second fluidic material comprises a non-hardenable fluidic material such as, for example, water, drilling mud or lubricant. The use of lubricant optimally provides lubrication of the moving parts of the apparatus 2700.

○

. . . . .

The second fluidic material may be pumped into the apparatus 2700 at operating pressures and flow rates ranging, for example, from about 0 to 4,500 psi and 0 to 4,500 gallons/minute. The second fluidic material is pumped into the apparatus 2700 at operating pressures and flow rates ranging from about 0 to 3,500 psi and 0 to 1,200 gallons/minute in order to optimally provide operational efficiency.

The pressurization of the pressure chambers 2915 and 2920 cause the upper sealing heads, 2725 and 2745, outer sealing mandrels, 2735 and 2755, and expansion cone 2765 to move in an axial direction. As the expansion cone 2765 moves in the axial direction, the expansion cone 2765 pulls the mandrel launcher 2770, casing 2790, and drag blocks 2785 along, which sets the mechanical slips 2780 and stops further axial movement of the mandrel launcher 2770 and casing 2790. In this manner, the axial movement of the expansion cone 2765 radially expands the mandrel launcher 2770 and casing 2790.

Once the upper sealing heads, 2725 and 2745, outer sealing mandrels, 2735 and 2755, and expansion cone 2765 complete an axial stroke, the operating pressure of the second fluidic material is reduced and the drill string 2705 is raised. This causes the inner sealing mandrels, 2720 and 2740, lower sealing heads, 2730 and 2750, load mandrel 2760, and mechanical slip body 2755 to move upward. This unsets the mechanical slips 2780 and permits the mechanical slips 2780 and drag blocks 2785 to be moved upward within the mandrel launcher 2770 and casing 2790. When the lower sealing heads, 2730 and 2750, contact the upper sealing heads, 2725 and 2745, the second fluidic material is again pressurized and the radial expansion process continues. In this manner, the mandrel launcher 2770 and casing 2790 are radially expanded through repeated axial strokes of the upper sealing heads, 2725 and 2745, outer sealing mandrels, 2735 and 2755, and expansion cone 2765. Throughout the radial expansion process, the upper end of the casing 2790 is preferably maintained in an overlapping relation with an existing section of wellbore casing.

At the end of the radial expansion process, the upper end of the casing 2790 is expanded into intimate contact with the inside surface of the lower end of the existing wellbore casing. The sealing members provided at the upper end of the casing 2790 provide a fluidic seal between the outside surface of the upper end of the casing 2790 and the inside surface of the lower end of the existing wellbore casing. The contact

pressure between the casing 2790 and the existing section of wellbore casing ranges from about 400 to 10,000 in order to optimally provide contact pressure for activating the scaling members, provide optimal resistance to axial movement of the expanded casing, and optimally resist typical tensile and compressive loads on the expanded casing.

5 As the expansion cone 2765 nears the end of the casing 2790, the operating pressure of the second fluidic material is reduced in order to minimize shock to the apparatus 2700. In an alternative embodiment, the apparatus 2700 includes a shock absorber for absorbing the shock created by the completion of the radial expansion of the casing 2790.

10 The reduced operating pressure of the second fluidic material ranges from about 100 to 1,000 psi as the expansion cone 2765 nears the end of the casing 2790 in order to optimally provide reduced axial movement and velocity of the expansion cone 2765.

15 The operating pressure of the second fluidic material is reduced during the return stroke of the apparatus 2700 to the range of about 0 to 500 psi in order minimize the resistance to the movement of the expansion cone 2765 during the return stroke. The stroke length of the apparatus 2700 ranges from about 10 to 45 feet in order to optimally provide equipment that can be easily handled by typical oil well rigging

20 equipment and minimize the frequency at which the apparatus 2700 must be re-stroked during an expansion operation.

In an alternative embodiment, at least a portion of the upper sealing heads, 2725 and 2745, include expansion cones for radially expanding the mandrel launcher 2770 and casing 2790 during operation of the apparatus 2700 in order to increase the surface area of the casing 2790 acted upon during the radial expansion process. In this manner, the operating pressures can be reduced.

In an alternative embodiment, mechanical slips are positioned in an axial location between the sealing sleeve 1915 and the first inner sealing mandrel 2720 in order to optimally provide a simplified assembly and operation of the apparatus 2700.

30 Upon the complete radial expansion of the casing 2790, if applicable, the first fluidic material is permitted to cure within the annular region between the outside of the expanded casing 2790 and the interior walls of the wellbore. In the case where the



drillpipe 3005 is removably coupled to the innerstring adapter 3010 by a drillpipe connection.

5 The drillpipe 3005 preferably includes a fluid passage 3080 that is adapted to convey fluidic materials from a surface location into the fluid passage 3085. The fluid passage 3080 is adapted to convey fluidic materials such as, for example, cement, epoxy, water, drilling mud or lubricants at operating pressures and flow rates ranging from about 0 to 9,000 psi and 0 to 3,000 gallons/minute.

10 The innerstring adapter 3010 is coupled to the drill string 3005 and the sealing sleeve 3015. The innerstring adapter 3010 preferably comprises a substantially hollow tubular member or members. The innerstring adapter 3010 may be fabricated from any number of conventional commercially available materials such as, for example, oilfield country tubular goods, low alloy steel, carbon steel, stainless steel, or other similar high strength materials. The innerstring adapter 3010 is fabricated from stainless steel in order to optimally provide high strength, corrosion resistance, and low friction surfaces.

15 The innerstring adapter 3010 may be coupled to the drill string 3005 using any number of conventional commercially available mechanical couplings such as, for example, drillpipe connection, oilfield country tubular goods specialty type threaded connection, or a standard threaded connection. The innerstring adapter 3010 is removably coupled to the drill pipe 3005 by a drillpipe connection. The innerstring adapter 3010 may be coupled to the sealing sleeve 3015 using any number of conventional commercially available mechanical couplings such as, for example, drillpipe connection, oilfield country tubular goods specialty type threaded connection, ratchet-latch type threaded connection or a standard threaded connection. The innerstring adapter 3010 is removably coupled to the sealing sleeve 3015 by a standard threaded connection.

25 The innerstring adapter 3010 preferably includes a fluid passage 3085 that is adapted to convey fluidic materials from the fluid passage 3080 into the fluid passage 3090. The fluid passage 3085 is adapted to convey fluidic materials such as, for example, cement, epoxy, water, drilling mud, or lubricants at operating pressures and flow rates ranging from about 0 to 9,000 psi and 0 to 3,000 gallons/minute.

○

The sealing sleeve 3015 is coupled to the innerstring adapter 3010 and the first inner scaling mandrel 3020. The sealing sleeve 3015 preferably comprises a substantially hollow tubular member or members. The sealing sleeve 3015 may be fabricated from any number of conventional commercially available materials such as, for example, oilfield country tubular goods, low alloy steel, carbon steel, stainless steel or other similar high strength materials. The sealing sleeve 3015 is fabricated from stainless steel in order to optimally provide high strength, corrosion resistance, and low friction surfaces.

The sealing sleeve 3015 may be coupled to the innerstring adapter 3010 using any number of conventional commercially available mechanical couplings such as, for example, drillpipe connection, oilfield country tubular goods specialty type threaded connection, ratchet-latch type connection or a standard threaded connection. The sealing sleeve 3015 is removably coupled to the innerstring adapter 3010 by a standard threaded connection. The sealing sleeve 3015 may be coupled to the first inner sealing mandrel 3020 using any number of conventional commercially available mechanical couplings such as, for example, drillpipe connection, oilfield country tubular goods specialty type threaded connection, ratchet-latch type threaded connection or a standard threaded connection. The sealing sleeve 3015 is removably coupled to the first inner sealing mandrel 3020 by a standard threaded connection.

The sealing sleeve 3015 preferably includes a fluid passage 3090 that is adapted to convey fluidic materials from the fluid passage 3085 into the fluid passage 3095. The fluid passage 3090 is adapted to convey fluidic materials such as, for example, cement, epoxy, water, drilling mud, or lubricants at operating pressures and flow rates ranging from about 0 to 9,000 psi and 0 to 3,000 gallons/minute.

The first inner sealing mandrel 3020 is coupled to the sealing sleeve 3015, the hydraulic slips 3025, and the first lower sealing head 3035. The first inner sealing mandrel 3020 is further movably coupled to the first upper sealing head 3030. The first inner sealing mandrel 3020 preferably comprises a substantially hollow tubular member or members. The first inner sealing mandrel 3020 may be fabricated from any number of conventional commercially available materials such as, for example, oilfield country tubular goods, low alloy steel, carbon steel, stainless steel, or similar high strength materials. The first inner sealing mandrel 3020 is fabricated from stainless



steel in order to optimally provide high strength, corrosion resistance, and low friction surfaces.

The first inner sealing mandrel 3020 may be coupled to the sealing sleeve 3015 using any number of conventional commercially available mechanical couplings such as, for example, drillpipe connection, oilfield country tubular goods specialty type threaded connection, ratchet-latch type threaded connection or a standard threaded connection. The first inner sealing mandrel 3020 is removably coupled to the sealing sleeve 3015 by a standard threaded connection. The first inner sealing mandrel 3020 may be coupled to the hydraulic slips 3025 using any number of conventional commercially available mechanical couplings such as, for example, drillpipe connection, oilfield country tubular goods specialty type threaded connection, ratchet-latch type threaded connection or a standard threaded connection. The first inner sealing mandrel 3020 is removably coupled to the hydraulic slips 3025 by a standard threaded connection. The first inner sealing mandrel 3020 may be coupled to the first lower sealing head 3035 using any number of conventional commercially available mechanical couplings such as, for example, drillpipe connection, oilfield country tubular goods specialty type threaded connection, ratchet-latch type threaded connection or a standard threaded connection. The first inner sealing mandrel 3020 is removably coupled to the first lower sealing head 3035 by a standard threaded connection.

The first inner sealing mandrel 3020 preferably includes a fluid passage 3095 that is adapted to convey fluidic materials from the fluid passage 3090 into the fluid passage 3100. The fluid passage 3095 is adapted to convey fluidic materials such as, for example, water, drilling mud, cement, epoxy, or lubricants at operating pressures and flow rates ranging from about 0 to 9,000 psi and 0 to 3,000 gallons/minute.

The first inner sealing mandrel 3020 further preferably includes fluid passages 3110 that are adapted to convey fluidic materials from the fluid passage 3095 into the pressure chambers of the hydraulic slips 3025. In this manner, the slips 3025 are activated upon the pressurization of the fluid passage 3095 into contact with the inside surface of the casing 3075. The fluid passages 3110 are adapted to convey fluidic materials such as, for example, cement, epoxy, water, drilling fluids or lubricants at

operating pressures and flow rates ranging from about 0 to 9,000 psi and 0 to 3,000 gallons/minute.

5 The first inner sealing mandrel 3020 further preferably includes fluid passages 3115 that are adapted to convey fluidic materials from the fluid passage 3095 into the first pressure chamber 3175 defined by the first upper sealing head 3030, the first lower sealing head 3035, the first inner sealing mandrel 3020, and the first outer sealing mandrel 3040. During operation of the apparatus 3000, pressurization of the pressure chamber 3175 causes the first upper sealing head 3030, the first outer sealing mandrel 3040, the second upper sealing head 3050, the second outer sealing mandrel 10 3060, and the expansion cone 3070 to move in an axial direction.

The slips 3025 are coupled to the outside surface of the first inner sealing mandrel 3020. During operation of the apparatus 3000, the slips 3025 are activated upon the pressurization of the fluid passage 3095 into contact with the inside surface of the casing 3075. In this manner, the slips 3025 maintain the casing 3075 in a 15 substantially stationary position.

The slips 3025 preferably include fluid passages 3125, pressure chambers 3130, spring bias 3135, and slip members 3140. The slips 3025 may comprise any number of conventional commercially available hydraulic slips such as, for example, RTTS packer tungsten carbide hydraulic slips or Model 3L retrievable bridge plug with 20 hydraulic slips. The slips 3025 comprise RTTS packer tungsten carbide hydraulic slips available from Halliburton Energy Services in order to optimally provide resistance to axial movement of the casing 3075 during the expansion process. The first upper sealing head 3030 is coupled to the first outer sealing mandrel 3040, the second upper sealing head 3050, the second outer sealing mandrel 3060, and the expansion cone 25 3070. The first upper sealing head 3030 is also movably coupled to the outer surface of the first inner sealing mandrel 3020 and the inner surface of the casing 3075. In this manner, the first upper sealing head 3030, the first outer sealing mandrel 3040, the second upper sealing head 3050, the second outer sealing mandrel 3060, and the expansion cone 3070 reciprocate in the axial direction.

30 The radial clearance between the inner cylindrical surface of the first upper sealing head 3030 and the outer surface of the first inner sealing mandrel 3020 may range, for example, from about 0.0025 to 0.05 inches. The radial clearance between

the inner cylindrical surface of the first upper sealing head 3030 and the outer surface of the first inner sealing mandrel 3020 ranges from about 0.005 to 0.01 inches in order to optimally provide minimal radial clearance. The radial clearance between the outer cylindrical surface of the first upper sealing head 3030 and the inner surface of the casing 3075 may range, for example, from about 0.025 to 0.375 inches. The radial clearance between the outer cylindrical surface of the first upper sealing head 3030 and the inner surface of the casing 3075 ranges from about 0.025 to 0.125 inches in order to optimally provide stabilization for the expansion cone 3070 during the expansion process.

10 The first upper sealing head 3030 preferably comprises an annular member having substantially cylindrical inner and outer surfaces. The first upper sealing head 3030 may be fabricated from any number of conventional commercially available materials such as, for example, oilfield country tubular goods, low alloy steel, carbon steel, or other similar high strength materials. The first upper sealing head 3030 is  
15 fabricated from stainless steel in order to optimally provide high strength, corrosion resistance, and low friction surfaces. The inner surface of the first upper sealing head 3030 preferably includes one or more annular sealing members 3145 for sealing the interface between the first upper sealing head 3030 and the first inner sealing mandrel 3020. The sealing members 3145 may comprise any number of conventional  
20 commercially available annular sealing members such as, for example, o-rings, polypak seals or metal spring energized seals. The sealing members 3145 comprise polypak seals available from Parker seals in order to optimally provide sealing for a long axial stroke.

25 The first upper sealing head 3030 includes a shoulder 3150 for supporting the first upper sealing head 3030, first outer sealing mandrel 3040, second upper sealing head 3050, second outer sealing mandrel 3060, and expansion cone 3070 on the first lower sealing head 3035.

30 The first upper sealing head 3030 may be coupled to the first outer sealing mandrel 3040 using any number of conventional commercially available mechanical couplings such as, for example, drillpipe connection, oilfield country tubular goods specialty type threaded connection, or a standard threaded connection. The first upper sealing head 3030 is removably coupled to the first outer sealing mandrel 3040 by a

standard threaded connection. The mechanical coupling between the first upper sealing head 3030 and the first outer sealing mandrel 3040 includes one or more sealing members 3155 for fluidically sealing the interface between the first upper sealing head 3030 and the first outer sealing mandrel 3040. The sealing members 3155 may  
5 comprise any number of conventional commercially available sealing members such as, for example, o-rings, polypak seals, or metal spring energized seals. The sealing members 3155 comprise polypak seals available from Parker Seals in order to optimally provide sealing for a long axial stroke.

The first lower sealing head 3035 is coupled to the first inner sealing mandrel  
10 3020 and the second inner sealing mandrel 3045. The first lower sealing head 3035 is also movably coupled to the inner surface of the first outer sealing mandrel 3040. In this manner, the first upper sealing head 3030, first outer sealing mandrel 3040, second upper sealing head 3050, second outer sealing mandrel 3060, and expansion cone 3070 reciprocate in the axial direction. The radial clearance between the outer surface of the  
15 first lower sealing head 3035 and the inner surface of the first outer sealing mandrel 3040 may range, for example, from about 0.0025 to 0.05 inches. The radial clearance between the outer surface of the first lower sealing head 3035 and the inner surface of the outer sealing mandrel 3040 ranges from about 0.005 to 0.01 inches in order to optimally provide minimal radial clearance.

The first lower sealing head 3035 preferably comprises an annular member  
20 having substantially cylindrical inner and outer surfaces. The first lower sealing head 3035 may be fabricated from any number of conventional commercially available materials such as, for example, oilfield country tubular goods, low alloy steel, carbon steel, stainless steel or other similar high strength materials. The first lower sealing  
25 head 3035 is fabricated from stainless steel in order to optimally provide high strength, corrosion resistance, and low friction surfaces. The outer surface of the first lower sealing head 3035 preferably includes one or more annular sealing members 3160 for sealing the interface between the first lower sealing head 3035 and the first outer  
30 sealing mandrel 3040. The sealing members 3160 may comprise any number of conventional commercially available annular sealing members such as, for example, o-rings, polypak seals, or metal spring energized seals. The sealing members 3160

comprise polypak seals available from Parker Seals in order to optimally provide sealing for a long axial stroke.

5 The first lower sealing head 3035 may be coupled to the first inner sealing mandrel 3020 using any number of conventional commercially available mechanical couplings such as, for example, drillpipe connection, oilfield country tubular goods specialty type threaded connection, ratchet-latch type threaded connection or a standard threaded connection. The first lower sealing head 3035 is removably coupled to the first inner sealing mandrel 3020 by a standard threaded connection. The mechanical coupling between the first lower sealing head 3035 and the first inner  
10 sealing mandrel 3020 includes one or more sealing members 3165 for fluidically sealing the interface between the first lower sealing head 3035 and the first inner sealing mandrel 3020. The sealing members 3165 may comprise any number of conventional commercially available sealing members such as, for example, o-rings, polypak seals, or metal spring energized seals. The sealing members 3165 comprise polypak seals  
15 available from Parker Seals in order to optimally provide sealing for a long axial stroke length.

The first lower sealing head 3035 may be coupled to the second inner sealing mandrel 3045 using any number of conventional commercially available mechanical couplings such as, for example, drillpipe connection, oilfield country tubular goods  
20 specialty type threaded connection, ratchet-latch type threaded connection or a standard threaded connection. The first lower sealing head 3035 is removably coupled to the second inner sealing mandrel 3045 by a standard threaded connection. The mechanical coupling between the first lower sealing head 3035 and the second inner sealing mandrel 3045 includes one or more sealing members 3170 for fluidically sealing  
25 the interface between the first lower sealing head 3035 and the second inner sealing mandrel 3045. The sealing members 3170 may comprise any number of conventional commercially available sealing members such as, for example, o-rings, polypak seals or metal spring energized seals. The sealing members 3170 comprise polypak seals available from Parker Seals in order to optimally provide sealing for a long axial  
30 stroke.

The first outer sealing mandrel 3040 is coupled to the first upper sealing head 3030 and the second upper sealing head 3050. The first outer sealing mandrel 3040 is

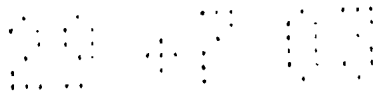

also movably coupled to the inner surface of the casing 3075 and the outer surface of the first lower sealing head 3035. In this manner, the first upper sealing head 3030, first outer sealing mandrel 3040, second upper sealing head 3050, second outer sealing mandrel 3060, and the expansion cone 3070 reciprocate in the axial direction. The radial clearance between the outer surface of the first outer sealing mandrel 3040 and the inner surface of the casing 3075 may range, for example, from about 0.025 to 0.375 inches. The radial clearance between the outer surface of the first outer sealing mandrel 3040 and the inner surface of the casing 3075 ranges from about 0.025 to 0.125 inches in order to optimally provide stabilization for the expansion cone 3070 during the expansion process. The radial clearance between the inner surface of the first outer sealing mandrel 3040 and the outer surface of the first lower sealing head 3035 may range, for example, from about 0.005 to 0.125 inches. The radial clearance between the inner surface of the first outer sealing mandrel 3040 and the outer surface of the first lower sealing head 3035 ranges from about 0.005 to 0.01 inches in order to optimally provide minimal radial clearance.

The first outer sealing mandrel 3040 preferably comprises an annular member having substantially cylindrical inner and outer surfaces. The first outer sealing mandrel 3040 may be fabricated from any number of conventional commercially available materials such as, for example, oilfield country tubular goods, low alloy steel, carbon steel, stainless steel or other similar high strength materials. The first outer sealing mandrel 3040 is fabricated from stainless steel in order to optimally provide high strength, corrosion resistance, and low friction surfaces.

The first outer sealing mandrel 3040 may be coupled to the first upper sealing head 3030 using any number of conventional commercially available mechanical couplings such as, for example, drillpipe connection, oilfield country tubular goods specialty type threaded connection, ratchet-latch type threaded connection or a standard threaded connection. The first outer sealing mandrel 3040 is removably coupled to the first upper sealing head 3030 by a standard threaded connection. The mechanical coupling between the first outer sealing mandrel 3040 and the first upper sealing head 3030 includes one or more sealing members 3180 for sealing the interface between the first outer sealing mandrel 3040 and the first upper sealing head 3030. The sealing members 3180 may comprise any number of conventional commercially

available sealing members such as, for example, o-rings, polypak seals or metal spring energized seals. The sealing members 3180 comprise polypak seals available from Parker Seals in order to optimally provide sealing for a long axial stroke.

5 The first outer sealing mandrel 3040 may be coupled to the second upper sealing head 3050 using any number of conventional commercially available mechanical couplings such as, for example, drillpipe connection, oilfield country tubular goods specialty type threaded connection, ratchet-latch type threaded connection, or a standard threaded connection. The first outer sealing mandrel 3040 is removably coupled to the second upper sealing head 3050 by a standard threaded  
10 connection. The mechanical coupling between the first outer sealing mandrel 3040 and the second upper sealing head 3050 includes one or more sealing members 3185 for sealing the interface between the first outer sealing mandrel 3040 and the second upper sealing head 3050. The sealing members 3185 may comprise any number of conventional commercially available sealing members such as, for example, o-rings,  
15 polypak seals or metal spring energized seals. The sealing members 3185 comprise polypak seals available from Parker Seals in order to optimally provide sealing for a long axial stroke.

The second inner sealing mandrel 3045 is coupled to the first lower sealing head 3035 and the second lower sealing head 3055. The second inner sealing mandrel  
20 3045 preferably comprises a substantially hollow tubular member or members. The second inner sealing mandrel 3045 may be fabricated from any number of conventional commercially available materials such as, for example, oilfield country tubular goods, low alloy steel, carbon steel, stainless steel or other similar high strength materials. The second inner sealing mandrel 3045 is fabricated from stainless  
25 steel in order to optimally provide high strength, corrosion resistance, and low friction surfaces.

The second inner sealing mandrel 3045 may be coupled to the first lower sealing head 3035 using any number of conventional commercially available mechanical couplings such as, for example, drillpipe connection, oilfield country  
30 tubular goods specialty type threaded connection, ratchet-latch type threaded connection or a standard threaded connection. The second inner sealing mandrel 3045 is removably coupled to the first lower sealing head 3035 by a standard threaded

connection. The second inner sealing mandrel 3045 may be coupled to the second lower sealing head 3055 using any number of conventional commercially available mechanical couplings such as, for example, drillpipe connection, oilfield country tubular goods specialty type threaded connection, ratchet-latch type connection, or a standard threaded connection. The second inner sealing mandrel 3045 is removably coupled to the second lower sealing head 3055 by a standard threaded connection.

The second inner sealing mandrel 3045 preferably includes a fluid passage 3100 that is adapted to convey fluidic materials from the fluid passage 3095 into the fluid passage 3105. The fluid passage 3100 is adapted to convey fluidic materials such as, for example, cement, epoxy, water, drilling mud or lubricants at operating pressures and flow rates ranging from about 0 to 9,000 psi and 0 to 3,000 gallons/minute.

The second inner sealing mandrel 3045 further preferably includes fluid passages 3120 that are adapted to convey fluidic materials from the fluid passage 3100 into the second pressure chamber 3190 defined by the second upper sealing head 3050, the second lower sealing head 3055, the second inner sealing mandrel 3045, and the second outer sealing mandrel 3060. During operation of the apparatus 3000, pressurization of the second pressure chamber 3190 causes the first upper sealing head 3030, the first outer sealing mandrel 3040, the second upper sealing head 3050, the second outer sealing mandrel 3060, and the expansion cone 3070 to move in an axial direction.

The second upper sealing head 3050 is coupled to the first outer sealing mandrel 3040 and the second outer sealing mandrel 3060. The second upper sealing head 3050 is also movably coupled to the outer surface of the second inner sealing mandrel 3045 and the inner surface of the casing 3075. In this manner, the second upper sealing head 3050 reciprocates in the axial direction. The radial clearance between the inner cylindrical surface of the second upper sealing head 3050 and the outer surface of the second inner sealing mandrel 3045 may range, for example, from about 0.0025 to 0.05 inches. The radial clearance between the inner cylindrical surface of the second upper sealing head 3050 and the outer surface of the second inner sealing mandrel 3045 ranges from about 0.005 to 0.01 inches in order to optimally provide minimal radial clearance. The radial clearance between the outer cylindrical surface of the second upper sealing head 3050 and the inner surface of the casing 3075 may



range, for example, from about 0.025 to 0.375 inches. The radial clearance between the outer cylindrical surface of the second upper sealing head 3050 and the inner surface of the casing 3075 ranges from about 0.025 to 0.125 inches in order to optimally provide stabilization for the expansion cone 3070 during the expansion process.

The second upper sealing head 3050 preferably comprises an annular member having substantially cylindrical inner and outer surfaces. The second upper sealing head 3050 may be fabricated from any number of conventional commercially available materials such as, for example, oilfield country tubular goods, low alloy steel, carbon steel, stainless steel or other similar high strength materials. The second upper sealing head 3050 is fabricated from stainless steel in order to optimally provide high strength, corrosion resistance, and low friction surfaces. The inner surface of the second upper sealing head 3050 preferably includes one or more annular sealing members 3195 for sealing the interface between the second upper sealing head 3050 and the second inner sealing mandrel 3045. The sealing members 3195 may comprise any number of conventional commercially available annular sealing members such as, for example, o-rings, polypak seals or metal spring energized seals. The sealing members 3195 comprise polypak seals available from Parker Seals in order to optimally provide sealing for a long axial stroke.

The second upper sealing head 3050 includes a shoulder 3200 for supporting the first upper sealing head 3030, first outer sealing mandrel 3040, second upper sealing head 3050, second outer sealing mandrel 3060, and expansion cone 3070 on the second lower sealing head 3055.

The second upper sealing head 3050 may be coupled to the first outer sealing mandrel 3040 using any number of conventional commercially available mechanical couplings such as, for example, drillpipe connection, oilfield country tubular goods specialty type threaded connection, ratchet-latch type threaded connection, or a standard threaded connection. The second upper sealing head 3050 is removably coupled to the first outer sealing mandrel 3040 by a standard threaded connection. The mechanical coupling between the second upper sealing head 3050 and the first outer sealing mandrel 3040 includes one or more sealing members 3185 for fluidically sealing the interface between the second upper sealing head 3050 and the first outer

sealing mandrel 3040. The second upper sealing head 3050 may be coupled to the second outer sealing mandrel 3060 using any number of conventional commercially available mechanical couplings such as, for example, drillpipe connection, oilfield country tubular goods specialty type threaded connection, ratchet-latch type threaded connection, or a standard threaded connection. The second upper sealing head 3050 is removably coupled to the second outer sealing mandrel 3060 by a standard threaded connection. The mechanical coupling between the second upper sealing head 3050 and the second outer sealing mandrel 3060 includes one or more sealing members 3205 for fluidically sealing the interface between the second upper sealing head 3050 and the second outer sealing mandrel 3060.

The second lower sealing head 3055 is coupled to the second inner sealing mandrel 3045 and the load mandrel 3065. The second lower sealing head 3055 is also movably coupled to the inner surface of the second outer sealing mandrel 3060. In this manner, the first upper sealing head 3030, first outer sealing mandrel 3040, second upper sealing mandrel 3050, second outer sealing mandrel 3060, and expansion cone 3070 reciprocate in the axial direction. The radial clearance between the outer surface of the second lower sealing head 3055 and the inner surface of the second outer sealing mandrel 3060 may range, for example, from about 0.0025 to 0.05 inches. The radial clearance between the outer surface of the second lower sealing head 3055 and the inner surface of the second outer sealing mandrel 3060 ranges from about 0.005 to 0.01 inches in order to optimally provide minimal radial clearance.

The second lower sealing head 3055 preferably comprises an annular member having substantially cylindrical inner and outer surfaces. The second lower sealing head 3055 may be fabricated from any number of conventional commercially available materials such as, for example, oilfield country tubular goods, low alloy steel, carbon steel, stainless steel, or other similar high strength materials. The second lower sealing head 3055 is fabricated from stainless steel in order to optimally provide high strength, corrosion resistance, and low friction surfaces. The outer surface of the second lower sealing head 3055 preferably includes one or more annular sealing members 3210 for sealing the interface between the second lower sealing head 3055 and the second outer sealing mandrel 3060. The sealing members 3210 may comprise any number of conventional commercially available annular sealing members such as, for example, o-

rings, polypak seals, or metal spring energized seals. The sealing members 3210 comprise polypak seals available from Parker Seals in order to optimally provide sealing for long axial strokes.

5 The second lower sealing head 3055 may be coupled to the second inner sealing mandrel 3045 using any number of conventional commercially available mechanical couplings such as, for example, drillpipe connection, oilfield country tubular goods specialty type threaded connection, or a standard threaded connection. The second lower sealing head 3055 is removably coupled to the second inner sealing mandrel 3045 by a standard threaded connection. The mechanical coupling between the lower  
10 sealing head 3055 and the second inner sealing mandrel 3045 includes one or more sealing members 3215 for fluidically sealing the interface between the second lower sealing head 3055 and the second inner sealing mandrel 3045. The sealing members 3215 may comprise any number of conventional commercially available sealing members such as, for example, o-rings, polypak seals or metal spring energized seals.  
15 The sealing members 3215 comprise polypak seals available from Parker Seals in order to optimally provide scaling for long axial strokes.

The second lower sealing head 3055 may be coupled to the load mandrel 3065 using any number of conventional commercially available mechanical couplings such as, for example, drillpipe connection, oilfield country tubular goods specialty type  
20 threaded connection, or a standard threaded connection. The second lower sealing head 3055 is removably coupled to the load mandrel 3065 by a standard threaded connection. The mechanical coupling between the second lower sealing head 3055 and the load mandrel 3065 includes one or more sealing members 3220 for fluidically sealing the interface between the second lower sealing head 3055 and the load mandrel  
25 3065. The sealing members 3220 may comprise any number of conventional commercially available sealing members such as, for example, o-rings, polypak seals or metal spring energized seals. The sealing members 3220 comprise polypak seals available from Parker Seals in order to optimally provide scaling for a long axial stroke.

30 The second lower sealing head 3055 includes a throat passage 3225 fluidically coupled between the fluid passages 3100 and 3105. The throat passage 3225 is preferably of reduced size and is adapted to receive and engage with a plug 3230, or

other similar device. In this manner, the fluid passage 3100 is fluidically isolated from the fluid passage 3105. In this manner, the pressure chambers 3175 and 3190 are pressurized. Furthermore, the placement of the plug 3230 in the throat passage 3225 also pressurizes the pressure chambers 3130 of the hydraulic slips 3025.

5           The second outer sealing mandrel 3060 is coupled to the second upper sealing head 3050 and the expansion cone 3070. The second outer sealing mandrel 3060 is also movably coupled to the inner surface of the casing 3075 and the outer surface of the second lower sealing head 3055. In this manner, the first upper sealing head 3030, first outer sealing mandrel 3040, second upper sealing head 3050, second outer sealing  
10 mandrel 3060, and the expansion cone 3070 reciprocate in the axial direction. The radial clearance between the outer surface of the second outer sealing mandrel 3060 and the inner surface of the casing 3075 may range, for example, from about 0.025 to 0.375 inches. The radial clearance between the outer surface of the second outer sealing mandrel 3060 and the inner surface of the casing 3075 ranges from about 0.025  
15 to 0.125 inches in order to optimally provide stabilization for the expansion cone 3070 during the expansion process. The radial clearance between the inner surface of the second outer sealing mandrel 3060 and the outer surface of the second lower sealing head 3055 may range, for example, from about 0.0025 to 0.05 inches. The radial clearance between the inner surface of the second outer sealing mandrel 3060 and the  
20 outer surface of the second lower sealing head 3055 ranges from about 0.005 to 0.01 inches in order to optimally provide minimal radial clearance.

          The second outer sealing mandrel 3060 preferably comprises an annular member having substantially cylindrical inner and outer surfaces. The second outer sealing mandrel 3060 may be fabricated from any number of conventional  
25 commercially available materials such as, for example, oilfield country tubular goods, low alloy steel, carbon steel, stainless steel or other similar high strength materials. The second outer sealing mandrel 3060 is fabricated from stainless steel in order to optimally provide high strength, corrosion resistance, and low friction surfaces.

          The second outer sealing mandrel 3060 may be coupled to the second upper  
30 sealing head 3050 using any number of conventional commercially available mechanical couplings such as, for example, drillpipe connection, oilfield country tubular goods specialty type threaded connection, or a standard threaded connection.

The outer sealing mandrel 3060 is removably coupled to the second upper sealing head 3050 by a standard threaded connection. The second outer sealing mandrel 3060 may be coupled to the expansion cone 3070 using any number of conventional commercially available mechanical couplings such as, for example, drillpipe connection, oilfield country tubular goods specialty type threaded connection, or a standard threaded connection. The second outer sealing mandrel 3060 is removably coupled to the expansion cone 3070 by a standard threaded connection.

The first upper sealing head 3030, the first lower sealing head 3035, the first inner sealing mandrel 3020, and the first outer sealing mandrel 3040 together define the first pressure chamber 3175. The second upper sealing head 3050, the second lower sealing head 3055, the second inner sealing mandrel 3045, and the second outer sealing mandrel 3060 together define the second pressure chamber 3190. The first and second pressure chambers, 3175 and 3190, are fluidically coupled to the passages, 3095 and 3100, via one or more passages, 3115 and 3120. During operation of the apparatus 3000, the plug 3230 engages with the throat passage 3225 to fluidically isolate the fluid passage 3100 from the fluid passage 3105. The pressure chambers, 3175 and 3190, are then pressurized which in turn causes the first upper sealing head 3030, the first outer sealing mandrel 3040, the second upper sealing head 3050, the second outer sealing mandrel 3060, and expansion cone 3070 to reciprocate in the axial direction. The axial motion of the expansion cone 3070 in turn expands the casing 3075 in the radial direction. The use of a plurality of pressure chambers, 3175 and 3190, effectively multiplies the available driving force for the expansion cone 3070.

The load mandrel 3065 is coupled to the second lower sealing head 3055. The load mandrel 3065 preferably comprises an annular member having substantially cylindrical inner and outer surfaces. The load mandrel 3065 may be fabricated from any number of conventional commercially available materials such as, for example, oilfield country tubular goods, low alloy steel, carbon steel, stainless steel or other similar high strength materials. The load mandrel 3065 is fabricated from stainless steel in order to optimally provide high strength, corrosion resistance, and low friction surfaces.

The load mandrel 3065 may be coupled to the lower sealing head 3055 using any number of conventional commercially available mechanical couplings such as, for

example, epoxy, cement, water, drilling mud, or lubricants. The load mandrel 3065 is removably coupled to the lower sealing head 3055 by a standard threaded connection.

5 The load mandrel 3065 preferably includes a fluid passage 3105 that is adapted to convey fluidic materials from the fluid passage 3100 to the region outside of the apparatus 3000. The fluid passage 3105 is adapted to convey fluidic materials such as, for example, cement, epoxy, water, drilling mud or lubricants at operating pressures and flow rates ranging from about 0 to 9,000 psi and 0 to 3,000 gallons/minute.

10 The expansion cone 3070 is coupled to the second outer sealing mandrel 3060. The expansion cone 3070 is also movably coupled to the inner surface of the casing 3075. In this manner, the first upper sealing head 3030, first outer sealing mandrel 3040, second upper sealing head 3050, second outer sealing mandrel 3060, and the expansion cone 3070 reciprocate in the axial direction. The reciprocation of the expansion cone 3070 causes the casing 3075 to expand in the radial direction.

15 The expansion cone 3070 preferably comprises an annular member having substantially cylindrical inner and conical outer surfaces. The outside radius of the outside conical surface may range, for example, from about 2 to 34 inches. The outside radius of the outside conical surface ranges from about 3 to 28 inches in order to optimally provide an expansion cone 3070 for expanding typical casings. The axial length of the expansion cone 3070 may range, for example, from about 2 to 8 times the maximum outer diameter of the expansion cone 3070. The axial length of the expansion cone 3070 ranges from about 3 to 5 times the maximum outer diameter of the expansion cone 3070 in order to optimally provide stabilization and centralization of the expansion cone 3070 during the expansion process. The maximum outside diameter of the expansion cone 3070 is between about 95 to 99 % of the inside diameter of the existing wellbore that the casing 3075 will be joined with. The angle of attack of the expansion cone 3070 ranges from about 5 to 30 degrees in order to optimally balance the frictional forces with the radial expansion forces.

25 The expansion cone 3070 may be fabricated from any number of conventional commercially available materials such as, for example, machine tool steel, nitride steel, titanium, tungsten carbide, ceramics, or other similar high strength materials. The expansion cone 3070 is fabricated from D2 machine tool steel in order to optimally provide high strength and resistance to wear and galling. The outside surface of the

expansion cone 3070 has a surface hardness ranging from about 58 to 62 Rockwell C in order to optimally provide high strength and resistance to wear and galling.

The expansion cone 3070 may be coupled to the second outside sealing mandrel 3060 using any number of conventional commercially available mechanical couplings such as, for example, drillpipe connection, oilfield country tubular goods specialty type threaded connection, ratchet-latch type connection or a standard threaded connection. The expansion cone 3070 is coupled to the second outside sealing mandrel 3060 using a standard threaded connection in order to optimally provide high strength and easy disassembly.

The casing 3075 is removably coupled to the slips 3025 and the expansion cone 3070. The casing 3075 preferably comprises a tubular member. The casing 3075 may be fabricated from any number of conventional commercially available materials such as, for example, slotted tubulars, oilfield country tubular goods, carbon steel, low alloy steel, stainless steel, or other similar high strength materials. The casing 3075 is fabricated from oilfield country tubular goods available from various foreign and domestic steel mills in order to optimally provide high strength.

The upper end 3235 of the casing 3075 includes a thin wall section 3240 and an outer annular sealing member 3245. The wall thickness of the thin wall section 3240 is about 50 to 100 % of the regular wall thickness of the casing 3075. In this manner, the upper end 3235 of the casing 3075 may be easily radially expanded and deformed into intimate contact with the lower end of an existing section of wellbore casing. The lower end of the existing section of casing also includes a thin wall section. In this manner, the radial expansion of the thin walled section 3240 of casing 3075 into the thin walled section of the existing wellbore casing results in a wellbore casing having a substantially constant inside diameter.

The annular sealing member 3245 may be fabricated from any number of conventional commercially available sealing materials such as, for example, epoxy, rubber, metal or plastic. The annular sealing member 3245 is fabricated from StrataLock epoxy in order to optimally provide compressibility and wear resistance. The outside diameter of the annular sealing member 3245 preferably ranges from about 70 to 95 % of the inside diameter of the lower section of the wellbore casing that the casing 3075 is joined to. In this manner, after radial expansion, the annular sealing

member 3245 optimally provides a fluidic seal and also preferably optimally provides sufficient frictional force with the inside surface of the existing section of wellbore casing during the radial expansion of the casing 3075 to support the casing 3075.

5 The lower end 3250 of the casing 3075 includes a thin wall section 3255 and an outer annular sealing member 3260. The wall thickness of the thin wall section 3255 is about 50 to 100 % of the regular wall thickness of the casing 3075. In this manner, the lower end 3250 of the casing 3075 may be easily expanded and deformed.

10 Furthermore, in this manner, an other section of casing may be easily joined with the lower end 3250 of the casing 3075 using a radial expansion process. The upper end of the other section of casing also includes a thin wall section. In this manner, the radial expansion of the thin walled section of the upper end of the other casing into the thin walled section 3255 of the lower end 3250 of the casing 3075 results in a wellbore casing having a substantially constant inside diameter.

15 The upper annular sealing member 3245 may be fabricated from any number of conventional commercially available sealing materials such as, for example, epoxy, rubber, metal or plastic. The upper annular sealing member 3245 is fabricated from Stratalock epoxy in order to optimally provide compressibility and resistance to wear. The outside diameter of the upper annular sealing member 3245 preferably ranges from about 70 to 95 % of the inside diameter of the lower section of the existing wellbore casing that the casing 3075 is joined to. In this manner, after radial expansion, the upper annular sealing member 3245 preferably provides a fluidic seal and also preferably provides sufficient frictional force with the inside wall of the wellbore during the radial expansion of the casing 3075 to support the casing 3075.

25 The lower annular sealing member 3260 may be fabricated from any number of conventional commercially available sealing materials such as, for example, epoxy, rubber, metal or plastic. The lower annular sealing member 3260 is fabricated from Stratalock epoxy in order to optimally provide compressibility and resistance to wear. The outside diameter of the lower annular sealing member 3260 preferably ranges from about 70 to 95 % of the inside diameter of the lower section of the existing wellbore casing that the casing 3075 is joined to. In this manner, the lower annular sealing member 3260 preferably provides a fluidic seal and also preferably provides



sufficient frictional force with the inside wall of the wellbore during the radial expansion of the casing 3075 to support the casing 3075.

5 During operation, the apparatus 3000 is preferably positioned in a wellbore with the upper end 3235 of the casing 3075 positioned in an overlapping relationship with the lower end of an existing wellbore casing. The thin wall section 3240 of the casing 3075 is positioned in opposing overlapping relation with the thin wall section and outer annular sealing member of the lower end of the existing section of wellbore casing. In this manner, the radial expansion of the casing 3075 will compress the thin wall sections and annular compressible members of the upper end 3235 of the casing 10 3075 and the lower end of the existing wellbore casing into intimate contact. During the positioning of the apparatus 3000 in the wellbore, the casing 3000 is preferably supported by the expansion cone 3070.

After positioning the apparatus 3000, a first fluidic material is then pumped into the fluid passage 3080. The first fluidic material may comprise any number of 15 conventional commercially available materials such as, for example, drilling mud, water, epoxy, cement, slag mix or lubricants. The first fluidic material comprises a hardenable fluidic sealing material such as, for example, cement, epoxy, or slag mix in order to optimally provide a hardenable outer annular body around the expanded casing 3075.

20 The first fluidic material may be pumped into the fluid passage 3080 at operating pressures and flow rates ranging, for example, from about 0 to 4,500 psi and 0 to 4,500 gallons/minute. The first fluidic material is pumped into the fluid passage 3080 at operating pressures and flow rates ranging from about 0 to 3,500 psi and 0 to 1,200 gallons/minute in order to optimally provide operating efficiency.

25 The first fluidic material pumped into the fluid passage 3080 passes through the fluid passages 3085, 3090, 3095, 3100, and 3105 and then outside of the apparatus 3000. The first fluidic material then preferably fills the annular region between the outside of the apparatus 3000 and the interior walls of the wellbore.

30 The plug 3230 is then introduced into the fluid passage 3080. The plug 3230 lodges in the throat passage 3225 and fluidically isolates and blocks off the fluid passage 3100. A couple of volumes of a non-hardenable fluidic material are then pumped into

the fluid passage 3080 in order to remove any hardenable fluidic material contained within and to ensure that none of the fluid passages are blocked.

5 A second fluidic material is then pumped into the fluid passage 3080. The second fluidic material may comprise any number of conventional commercially available materials such as, for example, water, drilling gases, drilling mud or lubricant. The second fluidic material comprises a non-hardenable fluidic material such as, for example, water, drilling mud, drilling gases, or lubricant in order to optimally provide pressurization of the pressure chambers 3175 and 3190.

10 The second fluidic material may be pumped into the fluid passage 3080 at operating pressures and flow rates ranging, for example, from about 0 to 4,500 psi and 0 to 4,500 gallons/minute. The second fluidic material is pumped into the fluid passage 3080 at operating pressures and flow rates ranging from about 0 to 3,500 psi and 0 to 1,200 gallons/minute in order to optimally provide operational efficiency.

15 The second fluidic material pumped into the fluid passage 3080 passes through the fluid passages 3085, 3090, 3095, 3100 and into the pressure chambers 3130 of the slips 3025, and into the pressure chambers 3175 and 3190. Continued pumping of the second fluidic material pressurizes the pressure chambers 3130, 3175, and 3190.

20 The pressurization of the pressure chambers 3130 causes the hydraulic slip members 3140 to expand in the radial direction and grip the interior surface of the casing 3075. The casing 3075 is then preferably maintained in a substantially stationary position.

25 The pressurization of the pressure chambers 3175 and 3190 cause the first upper sealing head 3030, first outer sealing mandrel 3040, second upper sealing head 3050, second outer sealing mandrel 3060, and expansion cone 3070 to move in an axial direction relative to the casing 3075. In this manner, the expansion cone 3070 will cause the casing 3075 to expand in the radial direction, beginning with the lower end 3250 of the casing 3075.

30 During the radial expansion process, the casing 3075 is prevented from moving in an upward direction by the slips 3025. A length of the casing 3075 is then expanded in the radial direction through the pressurization of the pressure chambers 3175 and 3190. The length of the casing 3075 that is expanded during the expansion process

will be proportional to the stroke length of the first upper sealing head 3030, first outer sealing mandrel 3040, second upper sealing head 3050, and expansion cone 3070.

Upon the completion of a stroke, the operating pressure of the second fluidic material is reduced and the first upper sealing head 3030, first outer sealing mandrel 5 3040, second upper sealing head 3050, second outer sealing mandrel 3060, and expansion cone 3070 drop to their rest positions with the casing 3075 supported by the expansion cone 3070. The reduction in the operating pressure of the second fluidic material also causes the spring bias 3135 of the slips 3025 to pull the slip members 3140 away from the inside walls of the casing 3075.

10 The position of the drillpipe 3075 is preferably adjusted throughout the radial expansion process in order to maintain the overlapping relationship between the thin walled sections of the lower end of the existing wellbore casing and the upper end of the casing 3235. The stroking of the expansion cone 3070 is then repeated, as necessary, until the thin walled section 3240 of the upper end 3235 of the casing 3075 15 is expanded into the thin walled section of the lower end of the existing wellbore casing. In this manner, a wellbore casing is formed including two adjacent sections of casing having a substantially constant inside diameter. This process may then be repeated for the entirety of the wellbore to provide a wellbore casing thousands of feet in length having a substantially constant inside diameter.

20 During the final stroke of the expansion cone 3070, the slips 3025 are positioned as close as possible to the thin walled section 3240 of the upper end 3235 of the casing 3075 in order minimize slippage between the casing 3075 and the existing wellbore casing at the end of the radial expansion process. Alternatively, or in addition, the outside diameter of the upper annular sealing member 3245 is selected to 25 ensure sufficient interference fit with the inside diameter of the lower end of the existing casing to prevent axial displacement of the casing 3075 during the final stroke. Alternatively, or in addition, the outside diameter of the lower annular sealing member 3260 is selected to provide an interference fit with the inside walls of the wellbore at an earlier point in the radial expansion process so as to prevent further axial 30 displacement of the casing 3075. In this final alternative, the interference fit is preferably selected to permit expansion of the casing 3075 by pulling the expansion

cone 3070 out of the wellbore, without having to pressurize the pressure chambers 3175 and 3190.

During the radial expansion process, the pressurized areas of the apparatus 3000 are preferably limited to the fluid passages 3080, 3085, 3090, 3095, 3100, 3110, 3115, 3120, the pressure chambers 3130 within the slips 3025, and the pressure chambers 3175 and 3190. No fluid pressure acts directly on the casing 3075. This permits the use of operating pressures higher than the casing 3075 could normally withstand.

Once the casing 3075 has been completely expanded off of the expansion cone 3070, the remaining portions of the apparatus 3000 are removed from the wellbore. The contact pressure between the deformed thin wall sections and compressible annular members of the lower end of the existing casing and the upper end 3235 of the casing 3075 ranges from about 400 to 10,000 psi in order to optimally support the casing 3075 using the existing wellbore casing.

In this manner, the casing 3075 is radially expanded into contact with an existing section of casing by pressurizing the interior fluid passages 3080, 3085, 3090, 3095, 3100, 3110, 3115, and 3120, the pressure chambers 3130 of the slips 3025 and the pressure chambers 3175 and 3190 of the apparatus 3000.

As required, the annular body of hardenable fluidic material is then allowed to cure to form a rigid outer annular body about the expanded casing 3075. In the case where the casing 3075 is slotted, the cured fluidic material preferably permeates and envelops the expanded casing 3075. The resulting new section of wellbore casing includes the expanded casing 3075 and the rigid outer annular body. The overlapping joint between the pre-existing wellbore casing and the expanded casing 3075 includes the deformed thin wall sections and the compressible outer annular bodies. The inner diameter of the resulting combined wellbore casings is substantially constant. In this manner, a mono-diameter wellbore casing is formed. This process of expanding overlapping tubular members having thin wall end portions with compressible annular bodies into contact can be repeated for the entire length of a wellbore. In this manner, a mono-diameter wellbore casing can be provided for thousands of feet in a subterranean formation.

As the expansion cone 3070 nears the upper end 3235 of the casing 3075, the operating flow rate of the second fluidic material is reduced in order to minimize shock to the apparatus 3000. In an alternative embodiment, the apparatus 3000 includes a shock absorber for absorbing the shock created by the completion of the radial expansion of the casing 3075.

The reduced operating pressure of the second fluidic material ranges from about 100 to 1,000 psi as the expansion cone 3070 nears the end of the casing 3075 in order to optimally provide reduced axial movement and velocity of the expansion cone 3070.

The operating pressure of the second fluidic material is reduced during the return stroke of the apparatus 3000 to the range of about 0 to 500 psi in order minimize the resistance to the movement of the expansion cone 3070 during the return stroke. The stroke length of the apparatus 3000 ranges from about 10 to 45 feet in order to optimally provide equipment that can be easily handled by typical oil well rigging equipment and also minimize the frequency at which the apparatus 3000 must be re-stroked.

In an alternative embodiment, at least a portion of one or both of the upper sealing heads, 3030 and 3050, includes an expansion cone for radially expanding the casing 3075 during operation of the apparatus 3000 in order to increase the surface area of the casing 3075 acted upon during the radial expansion process. In this manner, the operating pressures can be reduced.

Alternatively, the apparatus 3000 may be used to join a first section of pipeline to an existing section of pipeline. Alternatively, the apparatus 3000 may be used to directly line the interior of a wellbore with a casing, without the use of an outer annular layer of a hardenable material. Alternatively, the apparatus 3000 may be used to expand a tubular support member in a hole.

Referring now to Figure 21, an apparatus 3330 for isolating subterranean zones will be described. A wellbore 3305 including a casing 3310 are positioned in a subterranean formation 3315. The subterranean formation 3315 includes a number of productive and non-productive zones, including a water zone 3320 and a targeted oil sand zone 3325. During exploration of the subterranean formation 3315, the wellbore 3305 may be extended in a well known manner to traverse the various productive and

non-productive zones, including the water zone 3320 and the targeted oil sand zone 3325.

In order to fluidically isolate the water zone 3320 from the targeted oil sand zone 3325, an apparatus 3330 is provided that includes one or more sections of solid casing 3335, one or more external seals 3340, one or more sections of slotted casing 3345, one or more intermediate sections of solid casing 3350, and a solid shoe 3355.

The solid casing 3335 may provide a fluid conduit that transmits fluids and other materials from one end of the solid casing 3335 to the other end of the solid casing 3335. The solid casing 3335 may comprise any number of conventional commercially available sections of solid tubular casing such as, for example, oilfield tubulars fabricated from chromium steel or fiberglass. The solid casing 3335 comprises oilfield tubulars available from various foreign and domestic steel mills.

The solid casing 3335 is preferably coupled to the casing 3310. The solid casing 3335 may be coupled to the casing 3310 using any number of conventional commercially available processes such as, for example, welding, slotted and expandable connectors, or expandable solid connectors. The solid casing 3335 is coupled to the casing 3310 by using expandable solid connectors. The solid casing 3335 may comprise a plurality of such solid casings 3335.

The solid casing 3335 is preferably coupled to one more of the slotted casings 3345. The solid casing 3335 may be coupled to the slotted casing 3345 using any number of conventional commercially available processes such as, for example, welding, or slotted and expandable connectors. The solid casing 3335 is coupled to the slotted casing 3345 by expandable solid connectors.

The casing 3335 includes one more valve members 3360 for controlling the flow of fluids and other materials within the interior region of the casing 3335. In an alternative embodiment, during the production mode of operation, an internal tubular string with various arrangements of packers, perforated tubing, sliding sleeves, and valves may be employed within the apparatus to provide various options for commingling and isolating subterranean zones from each other while providing a fluid path to the surface.

The casing 3335 is placed into the wellbore 3305 by expanding the casing 3335 in the radial direction into intimate contact with the interior walls of the wellbore 3305.

The casing 3335 may be expanded in the radial direction using any number of conventional commercially available methods. The casing 3335 is expanded in the radial direction using one or more of the processes and apparatus described within the present disclosure.

5 The seals 3340 prevent the passage of fluids and other materials within the annular region 3365 between the solid casings 3335 and 3350 and the wellbore 3305. The seals 3340 may comprise any number of conventional commercially available sealing materials suitable for sealing a casing in a wellbore such as, for example, lead, rubber or epoxy. The seals 3340 comprise Stratalok epoxy material available from  
10 Halliburton Energy Services.

The slotted casing 3345 permits fluids and other materials to pass into and out of the interior of the slotted casing 3345 from and to the annular region 3365. In this manner, oil and gas may be produced from a producing subterranean zone within a subterranean formation. The slotted casing 3345 may comprise any number of  
15 conventional commercially available sections of slotted tubular casing. The slotted casing 3345 comprises expandable slotted tubular casing available from Petroline in Aberdeen, Scotland. The slotted casing 145 comprises expandable slotted sandscreen tubular casing available from Petroline in Aberdeen, Scotland.

The slotted casing 3345 is preferably coupled to one or more solid casing 3335.  
20 The slotted casing 3345 may be coupled to the solid casing 3335 using any number of conventional commercially available processes such as, for example, welding, or slotted or solid expandable connectors. The slotted casing 3345 is coupled to the solid casing 3335 by expandable solid connectors.

The slotted casing 3345 is preferably coupled to one or more intermediate solid  
25 casings 3350. The slotted casing 3345 may be coupled to the intermediate solid casing 3350 using any number of conventional commercially available processes such as, for example, welding or expandable solid or slotted connectors. The slotted casing 3345 is coupled to the intermediate solid casing 3350 by expandable solid connectors.

The last section of slotted casing 3345 is preferably coupled to the shoe 3355.  
30 The last slotted casing 3345 may be coupled to the shoe 3355 using any number of conventional commercially available processes such as, for example, welding or

expandable solid or slotted connectors. The last slotted casing 3345 is coupled to the shoe 3355 by an expandable solid connector.

In an alternative embodiment, the shoe 3355 is coupled directly to the last one of the intermediate solid casings 3350.

5 The slotted casings 3345 are positioned within the wellbore 3305 by expanding the slotted casings 3345 in a radial direction into intimate contact with the interior walls of the wellbore 3305. The slotted casings 3345 may be expanded in a radial direction using any number of conventional commercially available processes. The slotted casings 3345 are expanded in the radial direction using one or more of the  
10 processes and apparatus disclosed in the present disclosure with reference to Figures 14a-20.

The intermediate solid casing 3350 permits fluids and other materials to pass between adjacent slotted casings 3345. The intermediate solid casing 3350 may comprise any number of conventional commercially available sections of solid tubular casing such as, for example, oilfield tubulars fabricated from chromium steel or  
15 fiberglass. The intermediate solid casing 3350 comprises oilfield tubulars available from foreign and domestic steel mills.

The intermediate solid casing 3350 is preferably coupled to one or more sections of the slotted casing 3345. The intermediate solid casing 3350 may be  
20 coupled to the slotted casing 3345 using any number of conventional commercially available processes such as, for example, welding, or solid or slotted expandable connectors. The intermediate solid casing 3350 is coupled to the slotted casing 3345 by expandable solid connectors. The intermediate solid casing 3350 may comprise a plurality of such intermediate solid casing 3350.

25 Each intermediate solid casing 3350 includes one more valve members 3370 for controlling the flow of fluids and other materials within the interior region of the intermediate casing 3350. In an alternative embodiment, as will be recognized by persons having ordinary skill in the art and the benefit of the present disclosure, during the production mode of operation, an internal tubular string with various arrangements  
30 of packers, perforated tubing, sliding sleeves, and valves may be employed within the apparatus to provide various options for commingling and isolating subterranean zones from each other while providing a fluid path to the surface.



The intermediate casing 3350 is placed into the wellbore 3305 by expanding the intermediate casing 3350 in the radial direction into intimate contact with the interior walls of the wellbore 3305. The intermediate casing 3350 may be expanded in the radial direction using any number of conventional commercially available methods.

5 In an alternative embodiment, one or more of the intermediate solid casings 3350 may be omitted. One or more of the slotted casings 3345 are provided with one or more seals 3340.

The shoe 3355 provides a support member for the apparatus 3330. In this manner, various production and exploration tools may be supported by the shoe 10 3355. The shoe 3355 may comprise any number of conventional commercially available shoes suitable for use in a wellbore such as, for example, cement filled shoe, or an aluminum or composite shoe. The shoe 3355 comprises an aluminum shoe available from Halliburton. The shoe 3355 is selected to provide sufficient strength in compression and tension to permit the use of high capacity production and exploration 15 tools.

The apparatus 3330 includes a plurality of solid casings 3335, a plurality of seals 3340, a plurality of slotted casings 3345, a plurality of intermediate solid casings 3350, and a shoe 3355. More generally, the apparatus 3330 may comprise one or more solid casings 3335, each with one or more valve members 3360, n slotted casings 20 3345, n-1 intermediate solid casings 3350, each with one or more valve members 3370, and a shoe 3355.

During operation of the apparatus 3330, oil and gas may be controllably produced from the targeted oil sand zone 3325 using the slotted casings 3345. The oil and gas may then be transported to a surface location using the solid casing 3335. The 25 use of intermediate solid casings 3350 with valve members 3370 permits isolated sections of the zone 3325 to be selectively isolated for production. The seals 3340 permit the zone 3325 to be fluidically isolated from the zone 3320. The seals 3340 further permits isolated sections of the zone 3325 to be fluidically isolated from each other. In this manner, the apparatus 3330 permits unwanted and/or non-productive 30 subterranean zones to be fluidically isolated.

In an alternative embodiment, as will be recognized by persons having ordinary skill in the art and also having the benefit of the present disclosure, during the

production mode of operation, an internal tubular string with various arrangements of packers, perforated tubing, sliding sleeves, and valves may be employed within the apparatus to provide various options for commingling and isolating subterranean zones from each other while providing a fluid path to the surface.

5

5

Although illustrative embodiments of the invention have been shown and described, a wide range of modification, changes and substitution is contemplated in the foregoing disclosure. In some instances, some features of the present invention may be employed without a corresponding use of the other features.

10

### Table For Conversion To Metric Units

- 0 to 650 gallons/minute and 0 to 10,000 psi (0 to 2,460.51767 litres/minute and 0 to 689.476 bar)
- 1000 to 10000 psi (68.95 to 689.5 bar)
- 5 0.75 to 47 inches and 1.05 to 48 inches (1.905 to 119.38 centimetres and 2.667 to 121.92 centimetres)
- 0 to 3,000 gallons/minute and 0 to 9,000 psi (0 to 11356.24 litres/minute and 0 to 620.528 bar)
- 1,000 to 1,000 000 lbf (.478803 to 478.803 bar)
- 10 0 to 5,000 psi and 0 to 1,500 gallons/minute (0 to 344.738 bar and 0 to 5618.12 litres/minute)
- 400 to 10,000 psi and 30 to 4,000 gallons/min (27.58 to 689.476 bar and 113.56 to 15141.68 litres/minute)
- 500 to 9,000 psi and 40 to 3,000 gallons/min (34.47 to 620.53 bar and 151.42 to 11356.24 litres/minute)
- 15 500 to 9,000 psi (34.47 to 620.53 bar)
- 0 to 5 ft/sec (1.524 metres)
- 0 to 2 ft/sec (.6096 metres)
- 400 to 10,000 psi (27.58 to 689.476 bar)
- 20 5 feet (1.524 metres)
- 1.05 to 48 inches and 1/8 to 2 inches (2.667 to 121.92 and .3175 to 5.08 centimetres)
- 2.5 to 50 inches (6.35 to 127 centimetres)
- 1/16 to 1.25 inches (.159 to 3.175 centimetres)
- 3.5 to 19 inches and 1/8 to 1.25 (8.89 to 48.26 and .3175 to 3.175 centimetres)
- 25 40 to 20,000 feet (12.192 to 6096.00 metres)
- 40 to 3,000 gallons/minute and 500 to 9,000 psi (151.42 to 11356.24 litres/minute and 34.47 to 620.53 bar)
- 0 to 500 gallons/minute and 0 to 1,000 psi (0 to 1892.705 litres/minute and 0 to 68.95 bar)
- 40,000 to 135,000 psi (2757.90 to 9307.92 bar)
- 30 1/16 to 1.5 inches (.159 to 3.81 centimetres)
- 1/8 to 1.25 in (.3175 to 3.175 centimetres)
- 1.05 to 48 inches (2.667 to 121.92 centimetres)
- 3 ½ to 19 inches (8.89 to 48.26 centimetres)

- 2
- 2 to 5 feet (.6096 to 1.524 metres)  
 0 to 9,000 psi (0 to 620.528 bar)  
 1.125 to 3 inches (2.857 to 7.62 centimetres)  
 0.25 to 0.75 (0.635 to 1.905 centimetres)
- 5
- 3.5 to 19 in (8.89 to 48.26 centimetres)  
 0 to 9,000 psi and 0 to 3,000 gallons/minute (0 to 620.528 bar and 0 to 11356.24 litres/minute)  
 1,200 to 8,500 psi (82.737 to 586.054 bar)  
 40 to 1250 gallons/minute (151.416 to 4,731.765 litres/minute)
- 10
- 50 to 20,000 psi (3.447 to 137.95 bar)  
 3 to 15.5 inches and 3.5 to 16 inches (7.62 to 39.37 and 8.89 to 40.64 centimetres)  
 0 to 3,000 gallons/minute (0 to 11356.24 litres/minute)  
 1200 to 8500 psi and 40 to 1250 gallons/min (82.737 to 586.054 bar to 151.42 to 4731.76 litres/minute)
- 15
- 1200 to 8500 psi (82.737 to 586.054 bar)  
 500 to 10,000 psi (34.47 to 689.48 bar)  
 3/8 to 1 1/2 inches and 3 1/2 to 16 inches (.9525 to 3.81 and 8.89 to 40.64 centimetres)  
 0.625 to 0.75 inches and 3 to 19 inches (1.5875 to 1.905 and 7.62 to 48.26 centimetres)  
 5,000 to 20,000 psi (344.737 to 1,378.951 bar)
- 20
- 0.125 to 1.5 inches (.3175 to 3.81 centimetres)  
 0.25 to 1.0 inches (.635 to 2.54 centimetres)  
 240 to 480 inches (609.6 to 1219.2 centimetres)  
 0.05 to 0.75 inches (.127 to 1.905 centimetres)  
 0.1 to 0.5 inches (.254 to .127 centimetres)
- 25
- 0 to 500 gallons/minute and 0 to 9,000 psi (0 to 1892.705 litres/minute and 0 to 620.528 bar)  
 0 to 5,000 psi (0 to 344.737 bar)  
 0 to 9,000 psi and 0 to 500 gallons/minute (0 to 620.528 bar and 0 to 1892.705 litres/minute)
- 30
- 500 to 5,000 psi and 0 to 500 gallons/minute (34.47 to 344.737 bar and 0 to 1892.705 litres/minute)  
 0.025 to 0.05 inches (.0635 to .127 centimetres)  
 0.005 to 0.01 inches (.0127 to .0254 centimetres)

- 0.025 to 0.375 inches (.0635 to .9525 centimetres)
- 0.025 to 0.125 inches (.0635 to .3175 centimetres)
- 3 to 28 inches (7.62 to 71.12 centimetres)
- 0 to 4,500 psi, and 0 to 3,000 gallons/minute. (0 to 310.264 bar, and 0 to 11356.24  
 5 litres/minute)
- 0 to 4,500 psi, and 0 to 4,500 gallons/minute. (0 to 310.264 bar, and 0 to 17034.35  
 litres/minute)
- 0 to 3,500 psi, and 0 to 1,200 gallons/minute (0 to 241.316 bar and 0 to 4542.49  
 litres/minute)
- 10 100 to 1,000 psi (6.8947 to 68.947 bar)
- 10 to 45 feet (3.048 to 13.716 metres)
- 0.0025 to 0.05 inches (.00635 to .127 centimetres)
- 0.005 to 0.125 inches (.0127 to .3175 centimetres)
- 0 to 3,500 psi and 0 to 1,200 gallons/minute. (0 to 241.316 bar and 0 to 4542.49  
 15 litres/minute)
- 0 to 500 psi (0 to 34.47 bar)
- 0 to 9,000 psi and 0 to 5,000 gallons/minute (0 to 620.528 bar and 0 to 18927.05  
 litres/minute)
- 2 to 34 inches (5.08 to 86.36 centimetres)
- 20 0.15 to 1.5 inches (.381 to 3.81 centimetres)
- 2 to 34 inches. (5.08 to 86.36 centimetres)
- 3 to 15.5 inches (7.62 to 39.37 centimetres)
- 3.5 to 16 inches (8.89 to 40.64 centimetres)
- 120 to 2400 inches (304.8 to 6096.00 centimetres)
- 25 **The Following are Registered Trade Marks:**
- Super Scal (RTM)
- Halliburton Energy Services (RTM)
- Teflon (RTM)
- Lubriplate (RTM)
- 30 Dril Quip (RTM),
- Cameron (RTM)
- Breda (RTM)
- Petrolinc (RTM)

## CLAIMS

1. A method of extracting materials from a producing subterranean zone in a wellbore, at least a portion of the wellbore including a casing, comprising:  
positioning one or more primary solid tubulars within the wellbore;  
fluidicly coupling the primary solid tubulars with the casing;  
positioning one or more slotted tubulars within the wellbore, the slotted tubulars traversing the producing subterranean zone;  
plastically deforming at least some of the tubulars within the wellbore;  
fluidicly coupling the slotted tubulars with the solid tubulars;  
fluidicly isolating the producing subterranean zone from at least one other subterranean zone within the wellbore;  
fluidicly coupling at least one of the slotted tubulars from the producing subterranean zone;  
overlapping at least some of the tubulars with other tubulars; and  
wherein the inside diameters of the non-overlapping portions of the overlapping tubulars are substantially equal.
2. A method as claimed in claim 1, further comprising a seal at an interface between the one or more primary solid tubulars and the one or more slotted tubulars.
3. A method as claimed in any of the preceding claims, further comprising placing a seal at an interface between the one or more primary solid tubulars and the one or more slotted tubulars.
4. A method as claimed in claim 3, the seal comprising a compressible annular body.
5. A method as claimed in any of the preceding claims, wherein at least one of the one or more primary solid tubulars comprises a thin - wall end portion.

6. A method as claimed in any of the preceding claims, wherein at least one of the one or more slotted tubulars comprises a thin - wall end portion.
7. A method as claimed in claims 5 or 6, further comprising an interface between two adjacent thin - wall end portions.
8. A method as claimed in claim 7, further comprising a seal at said interface.
9. A method as claimed in claim 8, the seal comprising a compressible annular body.
10. A method as claimed in claims 5 or 6, wherein the plastically deforming at least some of the tubulars comprises plastically deforming at least two thin - wall end portions.